



Santa Ana College

Spring 2008 Schedule of Classes

Four-week intersession starts January 7, 2008 • Semester starts February 11, 2008

www.sac.edu

STUDENTS: Web access to student records and registration is on its way!
Go to www.sac.edu – click on online records and update your student profile with your personal email address.
We'll be in touch.

Santiago Canyon College classes on reverse side

Rancho Santiago Community College District Board of Trustees

Alfredo Amezcua, J.D. • R. David Chapel, Ed.D. • Brian E. Conley, M.A. • John R. Hanna • Lawrence R. "Larry" Labrado • Lisa Woolery • Phillip E. Yarbrough • Michele Hutchison, Student Trustee

Chancellor, Edward Hernandez, Jr., Ed.D.

Santa Ana College President, Erlinda J. Martinez, Ed.D.

Santiago Canyon College President, Juan A. Vázquez



Erlinda J. Martinez, Ed.D.

MESSAGE FROM THE PRESIDENT

Dear Students:

Welcome to Santa Ana College! The spring semester marks a new beginning. I invite you to experience the traditional or virtual classroom at Santa Ana College. Become part of an educational community, where individuals from all stages of life come to learn and grow.

With a significant growth in student enrollment last year, we continue to serve the community with outstanding academic and occupational programs and services. At Santa Ana College, you have the flexibility to select the schedule that works for you, including day and evening hours, weekends and online classes.

Our exceptional faculty and staff are committed to each and every one of you, priding themselves in the fact that our alumni have moved on to great accomplishments in areas such as business, public service, science and technology. We encourage you to reach for your potential.

SAC is your college! We are proud to have you and look forward to providing an exceptional educational experience.

See you around campus!

Erlinda J. Martinez, Ed. D.

TABLE OF CONTENTS

CALENDARS	1-2
HELP	4-5
CLASSES – Intersession, Weekend, GR8 Weeks, Honors, Online, Television, Freshman Experience, Learning Communities	3,18-26
ADMISSIONS / REGISTRATION	6-10
FEES / FINANCIAL ASSISTANCE	11, Insert Following Page 104
TESTS	12-13
POLICIES, NOTICES, GRADES	14-16
CLASSES – College Credit	27-87
SERVICES	88-90
ACADEMIC PLANNING	91-96
MAPS and LOCATIONS	103-104
CONTINUING EDUCATION – Programs & Locations	98-102

PARKING

CAMPUS PARKING INFORMATION

RSCCD requires parking permits for student and staff lots at Santa Ana College and Santiago Canyon College. Parking permits may be purchased at time of registration for \$16.00 in Room U-201, Johnson Center at Santa Ana College, as well as in the Cashier's Office at Santiago Canyon College. The purchase of your permit funds parking services and vehicle security when parked on campus.

REFUND OF PARKING FEE

Any student who withdraws from full-semester class(es) through the first two weeks of instruction may request a refund for his/her parking permit. The student is required to return the parking permit in its original condition. No refund will be allowed after the second week of instruction. No refund will be allowed if the parking permit is lost or stolen.

PARKING LOT DISCLAIMER

Rancho Santiago Community College District is not responsible for damages to, loss of, or thefts from vehicles parked on campus, except as defined under the applicable Government Codes of California, including [810-966.6].

CAUTION!

Parking in Bristol Marketplace, across the street from Santa Ana College, is not allowed. Violations will result in tow-aways.

SANTA ANA COLLEGE MISSION STATEMENT

The mission of Santa Ana College is to be a leader and partner in meeting the intellectual, cultural, technological, workforce and economic development needs of our diverse community. Santa Ana College prepares students for transfer, employment, careers and lifelong intellectual pursuits in a dynamic learning environment.

INDEX

Admissions	6	• Public Service Institute (PSI) Business Seminars	25	Nondiscrimination Policy	14
Assessment	91	• Television	25	Online Registration	9-10
Associate Degree Requirements	92-94	• Weekend	18-19	Parking	This Page
Board of Governor's Grant (BOGG) Application	Insert Following Page 104	Fees & Tuition	11	Placement Tests	12-21
Calendars	1-2	Final Exam Schedule	13	Policies & Notices	23-13
Certificate Requirements	94	Financial Aid	Insert Following Page 104	Prerequisites	91
CLASSES		General Education Requirements for CSUs	95	Refunds	11
• College Credit	27-87	Grades	14-16	Registration Information	6-10
• Community Services	88	HELP — Where to Find It!	4-5	Sexual Harassment Policy	14
• Continuing Education	98-102	How to Read This Schedule	17	Student Activities	97
• FAAst TrAAack	26	Información en español	4	STUDENT SERVICES	88-90
• Freshman Experience	26	Intersegmental General Education Transfer Curriculum (IGETC)	96	• Bookstore, Food Service, Library	88
• GR8 Weeks	20-21	Locations, Campus, Class, and Facility	17, 104	• Child Care Services	88
• Honors	19	MAPS		• Disabled Students	89
• Intersession	2-3	• District	103	• E.O.P.S.	89
• Learning Communities II	26	• Santa Ana College	104	• Psychological Services	90
• Online Classes	21-25			Telephone Registration	16-17

Santa Ana College

SPRING 2008 COLLEGE CREDIT (February 11 – June 8, 2008)

CLASS SCHEDULE

ADMISSIONS HOURS (see page 8 for Registration hours)

Monday – Thursday.....	8:00 AM – 8:45 PM	The college is closed December 24–31, 2007 and January 1, 2008 ❖ Office hours subject to change
Friday.....	8:00 AM – 4:30 PM	
Saturday (February 23 only)	8:30 AM – 12:30 PM	

REGISTRATION CALENDAR

November 26 – February 8, 2008.....	Online and Telephone registration for CONTINUING students (for specific date, see page 8)
January 14 – 21, 2008.....	Online and Telephone registration for MATRICULATING students (for students who have completed placement testing at SAC/SCC)
January 22 – February 8, 2008.....	NEW students register online or by telephone (appointment date/time is given at application time)
February 11 – April 4, 2008.....	Registration for late-starting classes continues by telephone and online

INSTRUCTIONAL CALENDAR

February 11, 2008.....	Instruction begins for Spring classes (full semester) and first GR8 Weeks session
April 14, 2008.....	Second GR8 Weeks classes begin
June 2 – June 8, 2008.....	Final Exams Week

CLASS ADD OR DROP DEADLINES

February 22, 2008.....	Last date to add a class with instructor signature
February 22, 2008.....	Last date to drop a class and not owe fees
February 22, 2008.....	Last date to drop a class and NOT receive a “W” grade
April 18, 2008.....	Last date to add a second GR8 Weeks class with instructor signature
April 18, 2008.....	Last date to drop a second GR8 Weeks class with enrollment fee refund
May 9, 2008.....	Last date to drop a full-semester class with a “W” grade

ACADEMIC FORM DEADLINES

March 3, 2008.....	Last date to file credit/no credit for first GR8 Weeks classes
March 14, 2008.....	Last date to file credit/no credit for full-semester classes
March 14, 2008.....	Last date to petition for CSU and IGETC
March 14, 2008.....	Last date to petition for June certificates
March 14, 2008.....	Last date to petition for June graduation
April 29, 2008.....	Last date to file credit/no credit for second GR8 Weeks classes

HOLIDAY CALENDAR

(If holiday is a Monday, weekend classes DO meet. If holiday is on a Friday, weekend classes DO NOT meet.)

January 1, 2008 (Tuesday)	New Year’s
January 21, 2008.....	Martin Luther King
February 15 – 18, 2008	President’s Holidays
April 7 – 13, 2008	Spring Break
May 26, 2008.....	Memorial Day

STUDENTS: We need Your Email address for a new student information system coming in the near future.

GO to www.sac.edu, **CLICK** on online records and **UPDATE** your student profile with your personal email address. Web access to student records and registration, twenty four/seven, is on its way!

We'll be in touch.



INTERSESSION

JANUARY 7 to FEBRUARY 1, 2007

INTERSESSION Calendar for Spring 2008 Classes

- Nov. 19, 2007 – January 4, 2008 Online (by computer) or telephone registration (closed 12/24/07–1/1/08)
- December 24 – January 1, 2008 College is closed for holidays
- January 7 Instruction begins
- January 11 Last day to add a class with instructor’s signature
- January 11 **Last day to drop a class with enrollment fee refund and no “W” grade**
- January 14 Last day to file Credit/No Credit
- January 25 Last day to drop a class with “W” grade
- Last Day of Class Intersession final exams
- February 1 Intersession ends
- February 11 Full Spring semester instruction begins

WHO is eligible to enroll for Intersession Classes?

- Continuing Students at SAC.
- New Students who have not submitted an application prior to December 21, 2007: Students should report directly to the first class meeting. Pending availability, students may be given an Add card by the instructor. Students must then apply in Admissions and take the Add card immediately to the Registration Area for processing.
(NOTE: English, EMLS, ESL, Math and Chemistry classes require placement testing.)

WHERE do I apply for the Intersession?

- Applications are available online, and at the SAC Admissions Office, (714) 564-6005.

HOW do I enroll for Intersession Classes?

- Enroll by telephone or online (by computer), November 19, 2007 – January 4, 2008. See pages 6–10 for registration help. (NOTE: College is closed for Christmas holidays, December 24 to January 1, 2008.)

CAN I enroll for Intersession classes using the telephone system or computer?

- Yes. For computer online enrollment, go to the college website—www.sac.edu—then click on Register Online, located on the top right corner (see page 18).
- For help with enrollment by telephone, follow the instructions on page 18 of this book.

PROBLEMS registering?

- Have you attended SAC or SCC during the Fall or Spring Semesters of 2007?
No: You need to submit an application prior to registering for classes—apply online.
Yes: Continue with the following questions.
- Are you using your Social Security Number as your student ID? Do you have a PERM number?
- Are you using the correct Action Code? (It is a 2-digit number followed by the # sign = 77#.)
- Have you completed the needed prerequisites for the class? If not, call Counseling and make an appointment, (714) 564-6100.
- Is it a restricted class? The computer will tell you if it is restricted. Call (714) 564-6019 for help (between 11/26/07–1/4/08 – closed 12/24/07-1/1/08).

Do I need a parking permit during the January Intersession classes?

- **No:** Permits are required beginning with the start of full semester classes!

STILL having problems? ---->Call SAC at (714) 564-6019 (between 11/26/07–1/4/08 closed 12/24/07–1/1/08)

SPRING 2008

INTERSESSION CLASSES

The following is a condensed listing of classes that meet entirely during the period **January 7 through February 1, 2008.**

Refer to the preceding page and the full class listing (beginning on page 27) for more complete information.

SANTA ANA COLLEGE

INTERSESSION CLASSES

COURSE	TKT #	TIME	DAYS	CAMPUS	DATES
ANTH 100 CULTL ANTH	0210001	8:00-11:35	MTWTh	SAC	1/08-1/31/08
ANTH 100H CULTURAL	0210031	1:00-4:35pm	MTWTh	SAC	1/08-1/31/08
ART 100 ART CONCP	0610001	9:00-1:15pm	TWTh	SAC	1/08-1/31/08
ART 100 ART CONCP	0610050	6:00-10:05pm	TWTh	SAC	1/08-1/31/08
ART 195 DIGITAL ART	0619502	9:00-1:15pm	TWThF	SAC	1/08-2/01/08
ASTR 109 INTR SOLA	0710905	9:00-12:10pm	TWThF	SAC	1/08-2/01/08
AUTO 082 SENSORS	0808201	6:00-10:15pm	TWTh	SAC	1/08-1/31/08
AUTO 098 L-1 ALTERN	0809801	6:00-10:15pm	TTh	SAC	1/08-1/31/08
BIOL 109 FUND/BIOL	1010999	8:00-11:10	MTWTh	SAC	1/07-1/31/08
BIOL 109L FUND LAB	1010997	6:00-9:10pm	MTWTh	SAC	1/07-1/31/08
BIOL 217 PATHOPHYS	1021702	Hrs Arr		SAC	1/07-1/31/08
BUS 130 PRSNL FIN	1113008	Hrs Arr		SAC	1/07-2/06/08
BUS 140 PRIN/FIN	1114002	Hrs Arr		SAC	1/07-2/02/08
BA 016 MODULES	1201603	9:00-1:10pm	MW	SAC	1/07-1/30/08
BA 110 COMP KEYB	1211002	9:00-1:05pm	TTh	SAC	1/08-1/31/08
BA 110 COMP KEYB	1211006	6:00-10:10pm	TTh	SAC	1/08-1/31/08
BA 115 COMP KEYB	1211502	9:00-1:05pm	TTh	SAC	1/08-1/31/08
BA 115 COMP KEYB	1211506	6:00-10:10pm	TTh	SAC	1/08-1/31/08
BA 147 INT WINDOW	1214701	7:00-10:10pm	MW	SAC	1/07-1/30/08
BA 188 MICRO XCEL	1218802	9:00-12:10pm	TTh	SAC	1/08-1/31/08
CHEM 109 CHEM/COMM	1410903	9:00-12:10pm	MTWTh	SAC	1/07-1/31/08
And		1:00-4:10pm	MTWTh	SAC	1/07-1/31/08
CHEM 209 INTRODUCT	1420909	9:30-12:40pm	MTWTh	SAC	1/07-1/31/08
And		1:10-4:20pm	MTWTh	SAC	1/07-1/31/08
CMPR 100 CMPR & SOC	1710023	8:00-12:15pm	TWTh	SAC	1/08-1/31/08
CMPR 100 CMPR & SOC	1710029	6:00-10:15pm	TWTh	SAC	1/08-1/31/08
CNSL N98 CAREER SVC	2009897	Hrs Arr		SAC	1/08-2/02/08
CNSL 100 LIFELONG	2010003	8:30-12:45pm	TTh	SAC	1/08-1/31/08
CNSL 116 PLAN/EXPL	2011650	6:00-10:15pm	TWTh	SAC	1/08-1/31/08
CNSL 116 PLAN/EXPL	2011651	Hrs Arr		SAC	1/08-1/31/08
CNSL 144 REASONING	2014450	8:00-12:15pm	TWTh	SAC	1/08-1/31/08
CNSL 144 REASONING	2014451	6:00-10:15pm	TWTh	SAC	1/08-1/31/08
CJ 101 INTR/CJ	2210117	8:00-11:20	MTWTh	SAC	1/07-1/31/08
ERTH 110 INTR/ERTH	2711009	6:30-9:50pm	MTWTh	SAC	1/07-1/31/08
ECON 120 MACRO	2812006	9:00-12:35pm	MTWTh	SAC	1/08-1/31/08
ECON 121 MICRO	2812110	6:00-9:35pm	MTWTh	SAC	1/08-1/31/08
ENGR 183 AUTOCAD 1	3218306	6:00-10:10pm	MTWTh	SAC	1/07-1/31/08
And		8 Hrs Arr		SAC	1/07-1/31/08
ENGR 184 AUTOCAD 2	3218405	6:00-10:10pm	MTWTh	SAC	1/07-1/31/08
And		8 Hrs Arr		SAC	1/07-1/31/08
ENGL 061 INTR/COMP	3306136	9:00-1:45pm	MTWTh	SAC	1/08-1/31/08
ENGL 101 FRSH COMP	3310160	9:00-1:45pm	MTWTh	SAC	1/08-1/31/08
ENGL 101 FRSH COMP	3310155	1:00-5:45pm	MTWTh	SAC	1/08-1/31/08
ENGL 101 FRSH COMP	3310150	5:45-10:30pm	MTWTh	SAC	1/08-1/31/08
ENGL 103 CRITICAL	3310311	9:00-1:45pm	MTWTh	SAC	1/08-1/31/08
ESFI 100 FITN EVAL	3590003	Hrs Arr		SAC	1/02-2/01/08
ESFI 109 CIRC TRAIN	3590905	Hrs Arr		SAC	1/02-2/02/08
ESFI 147 COED	3594702	6:30am-8:00	MTWTh	POOL	1/02-2/06/08
ESHE 101 HEALTHFUL	3610102	Hrs Arr		SAC	1/02-2/02/08
ESIA 124 CONDT MEN	3632405	9:00-11:30	MTWThF	SOCC	1/02-2/01/08
ESIA 124 CONDT MEN	3632403	1:00-3:45pm	MTWThF	TRCK	1/02-2/01/08
ESIA 124 CONDT MEN	3632404	3:00-5:30pm	MTWThF	BSBL	1/02-2/01/08
ESIA 124 CONDT MEN	3632402	4:15-6:45pm	MTWThF	SAC	1/02-2/01/08
ESIA 128 CONDT WOM	3632802	1:30-4:00pm	MTWThF	SAC	1/02-2/01/08
ESIA 128 CONDT WOM	3632803	3:00-6:00pm	MTWThF	TRCK	1/02-2/01/08
ESIA 160 THEORY SB	3636001	1:00-2:35pm	MTWThF	SAC	1/02-2/01/08
GEOG 100H HON WORLD	4510011	8:00-11:35	MTWTh	SAC	1/08-1/31/08
GEO 101 INTRO GEO	4610107	9:30-12:20pm	MTWThF	SAC	1/07-2/01/08
GEO 101L GEO LAB	4610108	1:30-4:20pm	MTWThF	SAC	1/07-2/01/08
HIST 101 16TH CENT	4810108	6:00-9:35pm	MTWTh	SAC	1/08-1/31/08

COURSE	TKT #	TIME	DAYS	CAMPUS	DATES
HIST 118 SOC/U.S.	4811803	6:00-9:35pm	MTWTh	SAC	1/08-1/31/08
HIST 121 FROM 1865	4812110	9:00-12:35pm	MTWTh	SAC	1/08-1/31/08
HIST 127 WOMN/U.S.	4812705	9:00-12:35pm	MTWTh	SAC	1/08-1/31/08
HU-D 200 LITERACY	4920002	7:00-9:50pm	MTWTh	SAC	1/08-2/05/08
IDS 155 SEXUALITY	5215505	11:30-2:50pm	MTWTh	SAC	1/07-1/31/08
MATH N06 ESSENTIAL	6300650	9:00-1:35pm	MTWTh	SAC	1/07-1/31/08
MATH N48 PRE ALGEB	6304850	8:00-12:35pm	MTWTh	SAC	1/07-1/31/08
MATH N48 PRE ALGEB	6304851	4:00-8:35pm	MTWTh	SAC	1/07-1/31/08
MATH 060 ELEME ALG	6306050	8:00-12:35pm	MTWTh	SAC	1/07-1/31/08
MATH 060 ELEME ALG	6306052	9:00-1:35pm	MTWTh	SAC	1/07-1/31/08
MATH 060 ELEME ALG	6306051	4:00-8:35pm	MTWTh	SAC	1/07-1/31/08
MATH 080 INT ALGEB	6308050	8:00-12:45pm	MTWThF	SAC	1/07-2/01/08
MATH 080 INT ALGEB	6308052	9:00-1:45pm	MTWThF	SAC	1/07-2/01/08
MATH 080 INT ALGEB	6308051	4:00-8:45pm	MTWThF	SAC	1/07-2/01/08
MATH 105 MATH/LIB	6310550	8:30-1:05pm	MTWTh	SAC	1/07-1/31/08
MATH 140 COLL ALGB	6314050	8:00-12:35pm	MTWTh	SAC	1/07-1/31/08
MATH 165 TUTORING	6316550	1:00-2:50pm	TTh	SAC	1/08-1/31/08
MATH 219 STATISTICS	6321950	8:30-1:15pm	MTWThF	SAC	1/07-2/01/08
MUS 101 MUS APPR	6510159	9:00-1:35pm	TWTh	SAC	1/08-1/31/08
MUS 103 JAZZ/AMER	6510399	9:00-1:05pm	TWTh	SAC	1/08-1/31/08
MUS 198 INTRO PROT	6519811	6:00-9:30pm	TWTh	DMC-204	1/08-1/31/08
N-CE 098 NCLEX GRAD	6709801	9:00-2:00pm	MTWThF	SAC	1/07-1/18/08
And		1 Hr Arr		SAC	1/07-1/18/08
N-CE 145 ADV SUPPRT	6714501	9:00-4:10pm	TTh	SAC	1/15-1/24/08
PARA 101 LAW OFFICE	5710101	Hrs Arr		SAC	1/08-1/31/08
PHAR 057 INPATIENT	7105701	9:00-1:25pm	MWF	SAC	1/07-2/01/08
PHIL 110 CRIT THINK	7211012	8:00-12:45pm	MTWTh	SAC	1/08-1/31/08
PHIL 110H CRIT THINK	7211075	5:00-9:45pm	MTWTh	SAC	1/08-1/31/08
PHIL 144 REASONING	7214450	8:00-12:15pm	TWTh	SAC	1/08-1/31/08
PHIL 144 REASONING	7214451	6:00-10:15pm	TWTh	SAC	1/08-1/31/08
POLT 101 INTR/GOVN	7610139	8:00-11:35	MTWTh	SAC	1/08-1/31/08
POLT 101 INTR/GOVN	7610142	9:00-12:35pm	MTWTh	SAC	1/08-1/31/08
POLT 101 INTR/GOVN	7610140	1:00-4:35pm	MTWTh	SAC	1/08-1/31/08
POLT 101 INTR/GOVN	7610141	6:00-9:35pm	MTWTh	SAC	1/08-1/31/08
PSYC 100 INTR/PSYC	7710027	9:00-12:35pm	MTWTh	SAC	1/08-1/31/08
READ N90A INDV READ	8009001	9:00-12:35pm	MTWTh	SAC	1/08-1/31/08
READ N90B INDV READ	8009021	9:00-12:35pm	MTWTh	SAC	1/08-1/31/08
READ 100A ADV READ	8010003	9:00-12:35pm	MTWTh	SAC	1/08-1/31/08
READ 100B ADV/READ	8010031	9:00-12:35pm	MTWTh	SAC	1/08-1/31/08
SOC 219 STATISTICS	8321950	8:30-1:15pm	MTWThF	SAC	1/07-2/01/08
SOC 100 INTR/SOC	8410006	6:00-9:35pm	MTWTh	SAC	1/08-1/31/08
SOC 100 INTR/SOC	8410081	Hrs Arr		TV	1/08-1/31/08
SOC 112 REL/MARRIA	8411207	Hrs Arr		SAC	1/08-1/31/08
SOC 112 REL/MARRIA	8411282	Hrs Arr		TV	1/08-1/31/08
SPAN N09A LANG LAB	8500902	Hrs Arr		SAC	1/08-2/01/08
SPAN 101 ELEMEN I	8510118	8:00-12:30pm	MTWThF	SAC	1/08-2/01/08
SPEC N57 ACQUIRED	8605702	Hrs Arr		SAC	1/08-2/01/08
SPEC N62 ASSESSMNT	8606201	Hrs Arr		SAC	1/08-2/01/08
SPEC N63 LEARNING	8606303	Hrs Arr		SAC	1/08-2/01/08
SPEC N91 COGNITIVE	8609101	Hrs Arr		SAC	1/08-1/31/08
SPCH N59 PRONUNCITN	8705901	10:00-12:25pm	MW	SAC	1/07-1/30/08
SPCH N98 NONNAT LAB	8709801	Hrs Arr		SAC	1/08-2/01/08
SPCH 101 INTR/COMM	8710189	8:30-1:00pm	MTTh	SAC	1/07-1/31/08
SPCH 102 PBLC SPKG	8710289	8:30-1:00pm	MTTh	SAC	1/07-1/31/08
SPCH 102 PBLC SPKG	8710203	6:00-10:15pm	TTh	SAC	1/08-1/31/08
And		9:00-1:15pm	S	SAC	1/08-1/31/08
STDY N95 TUTORING	8809503	Hrs Arr		SAC	1/08-2/02/08
TELV 104 FROM 1945	9010499	6:00-10:15pm	TWTh	SAC	1/08-1/31/08
TELV 198 INTRO PROT	9019801	6:00-9:30pm	TWTh	DMC-204	1/08-1/31/08
THEA 104 FILM/1945	9110499	6:00-10:15pm	TWTh	SAC	1/08-1/31/08

WE'RE HERE TO HELP . . .

Answers to your questions about

- Santa Ana College (www.sac.edu)
- Rancho Santiago Community College District (www.rscdd.org)
- Education and support centers, facilities, programs, services, and more . . .

For answers to questions about Santiago Canyon College, call (714) 628-4900.

TO CONTACT OR LEARN ABOUT . . .	ADMINISTRATOR/CONTACT	LOCATION	TELEPHONE
Academic Computing Center	John Luxenberg	SAC, Cesar Chavez Building, A-106	564-6731
Acquired Brain Impairment Program	Renee Miller	SAC, Planetarium, M-105	564-6280
ACT Center	Eileen Granosky	RSCCD, 2323 N. Broadway, Rm. 315, Santa Ana, CA 92706	480-7560
Add or Drop Class	SAC Registration	SAC, Johnson Campus Center, U-202	564-6031
Admissions	SAC Admissions/Records Staff	SAC, Administration Building, S-Lobby	564-6015
American Sign Language	Monica Collins	SAC, Johnson Campus Center, U-107	(TDD 564-6284) 564-6283
AmeriCorps Foster Youth Mentoring Project	Byron Clift Breland	SAC, Johnson Campus Center, U-121A	564-6324
Articulation—High Schools/ROPS		SAC, Russell Hall, R-107	564-6224
Articulation—Universities	Paula Canzona	SAC, Administration Building, S-107-2	564-6088
Assistive Technology Center	Don Dutton	SAC, Johnson Campus Center, U-103	564-6260
Athletics	Mickey Davis	SAC, Exercise Science Building, W-102	564-6900
Bookstore	Jared Ceja/Bookstore Staff	SAC, Johnson Campus Center	564-6435
CalWORKs	David Guzman	SAC, Library Building, L-222	564-6288
Career/Job Resource Center	Marisela Godinez	SAC, Library Building, L-225	564-6254
Cashier's Office	Cashier's Office Staff	SAC, Administration Building, S-104	564-6965
Centennial Education Center (CEC)		CEC, 2900 W. Edinger, Santa Ana, CA 92704	241-5700
Child Development Services	Executive Director, Dee Tucker	RSCCD District Office, 2323 N. Broadway, Santa Ana, CA 92706	480-7546
<i>Santa Ana College.</i>	Debbie McBee	SAC, across street west of campus at 1720 W. 17th St., Santa Ana	564-6894
<i>Centennial Education Center.</i>	Veronica MacKenney	CEC, 2900 W. Edinger, Santa Ana	241-5739
Clubs/Organizations	Liz Monge	SAC, Johnson Campus Center, U-121A	564-6214
Community Relations	Teresa Mercado-Cota	RSCCD District Office, 2323 N. Broadway, Santa Ana, CA 92706	480-7505
Community Services	Lithia Williams	SAC, Administration Building, S-204	564-6594
Communication Disabilities	Renee Miller	SAC, Planetarium, M-105	564-6280
Computer Lab	John Luxenberg	SAC, Cesar Chavez Building, A-106	564-6731
Continuing Education Division			
Centennial Education Center	Kathy Mennealy	CEC, 2900 W. Edinger, Santa Ana	241-5700
Cooperative Work Experience	Hilda Roberts	SAC, Cesar Chavez Building, A-103	564-6750
Counseling	SAC Counseling Center Staff	SAC, Administration Building, S-109	564-6100
Criminal Justice Academies	George Troxil	OC Sheriff's Regional Training Academy, 15991 Armstrong Ave., Tustin, 92782.	566-9200
Deaf and Hard of Hearing	Monica Collins	SAC, Johnson Campus Center, U-107	(TDD 564-6284) 564-6283
Developmentally Delayed Learners	Nell Kenyon	SAC, Johnson Campus Center, U-141	564-6273
Digital Media Center	Bart Hoffman	DMC, 1300 S. Bristol Street, Santa Ana, CA 92708	241-5812
Disabled Student Programs and Services (see page 89)	Jane Mathis	SAC, Johnson Campus Center, U-103	564-6260
Distance Education (Online Classes)	Distance Education Office Staff	SAC, Russell Hall, R-105	564-6725
DISTRICT OFFICE		RSCCD District Office, 2323 N. Broadway, Santa Ana, CA 92706	480-7300
DISTRICT SAFETY AND SECURITY DIVISIONS/DEPARTMENTS	Al Chin	RSCCD District Office, 2323 N. Broadway, Santa Ana, CA 92706	480-7331
Business	Hilda Roberts	SAC, Cesar Chavez Building, A-103	564-6750
Counseling	Micki Bryant	SAC, Administration Building, S-105	564-6078
Exercise Science, Health and Athletics	Avie Bridges	SAC, Physical Education Building, W-102	564-6900
Fine & Performing Arts	Thom B. Hill	SAC, Cesar Chavez Building, A-109	564-5600
Humanities & Social Sciences	Sharon Whelan	SAC, Dunlap Hall, D-435-2	564-6500
Human Services & Technology	Ed Ripley	SAC, Russell Hall, R-107	564-6800
Career Education & Workforce Development	Ed Ripley	SAC, Russell Hall, R-118	564-6106
Science, Math, and Health Sciences	Carol Comeau	SAC, Russell Hall, R-103	564-6600
Economic Development	Kari Caldwell	RSCCD District Office, 2323 N. Broadway, Santa Ana, CA 92706	564-5529
Educational Services	Julie Stark	RSCCD District Office, 2323 N. Broadway, Santa Ana, CA 92706	480-7460
EMERGENCY	SAC District Safety Staff	SAC, Security/Safety Building, X-100	564-6333
Emergency Services (<i>Earthquake Preparedness</i>)	Al Chin	RSCCD District Office, 2323 N. Broadway, Santa Ana, CA 92706	480-7330

ALTERNATE FORMATS

Upon request, Santa Ana College materials will be available in alternate formats. Please contact DSPS at 714-564-6260.

CLASS SCHEDULE

also available online at www.sac.edu

Prepared each semester, the class schedule includes general information, courses offered, hours, rooms, and instructor names. Schedules are mailed to all district high schools and are available at SAC & SCC Bookstores. Because the schedule is prepared prior to the start of classes, the information published is subject to change. Use the online course availability for the most current information.

Telephone assistance in Spanish

¡Se le puede asistir en español!

Información en español sobre Santa Ana College (714) 564-6100

Lunes a jueves de 8:00 a.m. – 8:00 p.m.

Viernes de 8:00 a.m. – 5:00 p.m.

Admisiones / Evaluación/Orientación / Inscripciones / Servicios de consejería

Ayuda financiera / Clases generales / Ciudadanía

Programas académicos y vocacionales / Otros servicios . . .

Información en español acerca de clases de educación para adultos en la página 98.

TO CONTACT OR LEARN ABOUT . . .	ADMINISTRATOR/CONTACT	LOCATION	TELEPHONE
English as a Second Language	Humanities & Social Sciences Division	SAC, Dunlap Hall, D-435	564-6500
Environmental Safety/Crime Prevention	Al Chin	RSCCD District Office, 2323 N. Broadway, Santa Ana	480-7330
EOPS	Aurora Kamimura	SAC, Johnson Campus Center, U-101	564-6232
FAAst TRAAck Program	Lucy Sims	SAC, Russell Hall, R-118	564-6224
Facility Reservations	Maria Garcia	SAC, Administration Building S-201	564-6227
Financial Aid	Mark Liang	SAC, Johnson Campus Center, U-221	564-6242
Fire Technology	Richard Bridges	SAC, Cesar Chavez Building, A-113	564-6845
Foundation	Christina Romero	SAC, Administration Building, S-217	564-6091
Freshman Experience, Learning Communities II	John Acuña	SAC, Administration Building, S-109	564-6117
Graduation	Christine Gorlato/Gina Wilson	SAC, Administration Building, S-216	564-6052
Hazardous Materials	Al Chin	RSCCD District Office, 2323 N. Broadway, Santa Ana	480-7330
Health Services	Arlene Warco	SAC, Johnson Campus Center, U-120	564-6216
Honors Transfer Program	Kathy Patterson	SAC, Dunlap Hall, D-428	564-6528
Human Resources	John Didion	RSCCD District Office, 2323 N. Broadway, Santa Ana, CA 92706	480-7484
I-20 Form	Donna Tolley	SAC, B-12	564-6047
Information, General	Admissions/Records Staff	SAC, S-Lobby	564-6000
International Students	Donna Tolley	SAC, B-12	564-6047
Internet access to RSCCD on the World Wide Web		RSCCD: www.rscdd.org ; SAC: www.sac.edu ; SCC: www.sccollege.edu	
Learning Center	Jane Mathis	SAC, Johnson Campus Center, U-103	564-6260
Learning Disabilities	Mary Kobane/Brooke Choo	SAC, Johnson Campus Center, U-103	564-6260
Learning Skills Lab (<i>Centennial Education Center</i>)	Mary Stephens	CEC, D-101	241-5768
Library	SAC Library Staff	SAC, Nealley Library	564-6700
Lost & Found	SAC District Safety Staff	SAC, Security/Safety Building, X-100	564-6330
Marketplace Education Center (MEC)	Sergio Sotelo	MEC, 201 East 4th Street, Santa Ana, CA 92701	564-5000
MESA (Math, Engineering, & Science Achievement)	Yolanda Mugica	SAC, Administration Building, S-132	564-6373
Military Evaluation/Veteran's Affairs	Gloria Lewis	SAC, Administration Building, S-216	564-6050
Nursing	Becky Miller	SAC, Russell Hall, R-213	564-6825
Office of School & Community Partnerships	Lilia Tanakeyowma	SAC, Administration Building, S-209	564-6970
Online Classes/Distance Education	Jacque O'Lea	SAC, Russell Hall, R-105	564-6725
Outreach	Lilia Tanakeyowma	SAC, Administration Building, S-203	564-6141
Parking	James Wooley	SAC, Security/Safety Building, X-100	564-6330
Photo ID	Rhonda Langston	SAC, Administration Building, Cashier's Office, S-104	564-6965
Physical Disabilities	Mary Majors	SAC, Russell Hall, R-101	564-6295
Psychological Disabilities		SAC, Johnson Campus Center, U-103	564-6260
Psychological Services	Phi Loan Le	SAC, Johnson Campus Center, U-120	564-6216
Public Relations	Nikita Flynn	SAC, Security/Safety Building, X-101	564-6475
Public Service Institute, Business Seminars	Dianne Freman	DMC, 1300 S. Bristol Street, Santa Ana, CA 92708, DMC-209	241-5823
Puente Program	Reina Sanabria	SAC, Administration Building, S-209	564-6100
RSCCD District Office		RSCCD District Office, 2323 N. Broadway, Santa Ana, CA 92706	480-7300
Rancho Santiago Community College District Foundation		RSCCD District Office, 2323 N. Broadway, Santa Ana, CA 92706	480-7340
Registration	SAC Registration Area Staff	SAC, Johnson Campus Center, U-102	564-6017
Research Department	Nga Pham	RSCCD District Office, 2323 N. Broadway, Santa Ana, CA 92706	480-7468
Residency	SAC Admissions/Records Staff	SAC, Administration Building, S-101	564-6005
Resource Development Department	Janie Marcus	RSCCD District Office, 2323 N. Broadway, Santa Ana, CA 92706	480-7463
Santa Ana Civic Leadership Initiative	Byron Breland	SAC, Johnson Campus Center, U-121A	564-6363
Santa Ana College (SAC)		SAC, 1530 W. 17th Street, Santa Ana, CA 92706	564-6000
Scholarships	Stephanie Adams	SAC, Administration Building, S-204	564-6478
Security	James Wooley	SAC, Security/Safety Building, X-100	564-6330
Service Learning Center	Ana Aguayo	SAC, Johnson Campus Center, U-100A	564-6362
Small Business Development Center, Orange County	Leila Mozaffari	RSCCD, 2323 N. Broadway, Rm. 201, Santa Ana, CA 92706	564-5200
Spanish Language Telephone Assistance		SAC	564-6100
Special Services	David Guzman	SAC, Library Building, L-222	564-6288
Speech Language Pathology Assistant Program	Monica Porter	SAC, Library Building, L-222-3	564-6668
Student Activities	Liz Monge	SAC, Johnson Campus Center, U-121A	564-6210
Student Affairs	Lilia Tanakeyowma	SAC, Johnson Campus Center, S-203	564-6140
Student Business Office	Rhonda Langston	SAC, Johnson Campus Center, U-218	564-6430
(Office of) Student Life		SAC, Johnson Campus Center, U-121A	564-6211
Student Government	Liz Monge	SAC, Johnson Campus Center, U-121A	564-6214
Student Leadership Institute	Byron Clift Breland	SAC, Johnson Campus Center, U-121A	564-6330
Student Placement	Janet Grunbaum	SAC, Johnson Campus Center, U-222	564-6201
Student Support Services Program (TRIO)	Romelia Madrigal	SAC, Library Building, L-222	564-6843
Student Transition Program	Luis Dorado	CEC, 2900 W. Edinger, Santa Ana, CA 92704	241-5710
Success Center	Kathleen Simmons	SAC, Library Building, L-206	564-5420
Talent Search (TRIO)	Marco Ramirez	SAC, Library Building, L-220-S	564-6182
Teacher Education Center	Steve Bautista	SAC, Administration Building, S-132	564-6352
Tech Prep	John Kalko	SAC, Russell Hall, R-320	564-6629
Television/TV Class Information	Distance Education Office Staff	SAC, Russell Hall, R-105	564-6725
Testing Information	Beverly Birnbaum	SAC, Library Building, L-221	564-6148
Transcripts	SAC Admissions/Records Staff	SAC, Administration Building, S-101	564-6461
Transfer Center	Martha Vargas	SAC, Administration Building, S-132	564-6165
Tutorial Center	Pat Conner	SAC, Johnson Campus Center, U-103	564-6260
U-Link	Rochelle Zook	SAC, Administration Building, S-133	564-6416
Upward Bound (TRIO)	Romelia Madrigal	SAC, Library Building, L-222	564-6843
Veterans Affairs	Gloria Lewis	SAC, Administration Building, S-216	564-6050
Women's Programs/Services	Cindy Sorensen	SAC, Administration Building, S-122	564-6175
Workability	Sandy Morris-Pfyl	SAC, Library Building, L-220	564-6255
Workplace Learning Resource Center	Eileen Granosky	RSCCD, 2323 N. Broadway, Rm. 328, Santa Ana, CA 92706	564-5521

VISIT OUR WEBSITES

SANTA ANA COLLEGE – www.sac.edu SANTIAGO CANYON COLLEGE – www.sccollege.edu RANCHO SANTIAGO COMMUNITY COLLEGE DISTRICT – www.rscdd.org

IF YOU CAN'T FIND WHAT YOU NEED IN THE LIST ABOVE, PLEASE CALL 714-564-6000 (SAC) OR 714-628-4900 (SCC).

ADMISSIONS / REGISTRATION

STEP 1: APPLICATION

ADMISSIONS

- **Continuing Students**
Continuing students who actively attended Spring 2007 or Fall 2007 are mailed registration reminders in November and may complete registration by telephone or computer. See the registration schedule on page 8.
- **New Students and Former (Returning) Students**
Students enrolling for the first time or who are returning after **not** attending Spring 2007 or Fall 2007 must complete an Admission application. **Applications for Spring should be filed before February 1, 2008.**
You may also apply online at www.sac.edu.
- **Registration appointments for new students are processed on a first-come, first-serve basis at the time of application.**

WHO MAY ATTEND

- **High school graduates** or persons at least 18 years of age who may profit from instruction.
- High school students in **Career Advanced Placement Program (CAP)**
The CAP program is designed for high school students. A significant portion of the Santa Ana College curriculum is available to supplement programs of high school students recommended by their principals. Contact the Admissions office for details.
NOTE: CAP students must register in person. Bring the CAP form signed by your high school principal, parent and the appropriate Santa Ana College Division Dean. Due to a new state law, students who wish to take classes at a community college must be assigned low enrollment priority so as not to displace regularly admitted students.
- **International Students**
International students are eligible for admission under a student visa (F-1). Apply through the International Student Office, Santa Ana College, for forms and instructions. Deadlines are June 1 for the Fall semester and December 1 for Spring.

STEP 2: REGISTRATION

CONTINUING STUDENT

You are a continuing student if you were enrolled in college credit classes at SAC during the Spring 2007 or Fall 2007 semesters.

EARLY REGISTRATION FOR CONTINUING STUDENTS:

- **Online and Telephone registration (see page 8) is available for continuing students. Priority is based on units earned at SAC & SCC only.**
- Use any touchtone telephone or computer to enroll.
- **Continuing students** who do not meet the early registration deadline may register online or by telephone until the Thursday before the semester begins.

REGISTRATION (continued)

TRANSFER STUDENT

INFORMATION FOR NEW STUDENTS FROM OTHER COLLEGES

If you have attended another college, especially another community college, you must:

- Bring a copy of your official transcript to Counseling and meet with a counselor. If you completed a prerequisite outside of SAC or SCC, you will be restricted from online or telephone registration for some classes. You must obtain a CLASS WAIVER from SAC Counseling before you register.
- Bring any official copies of placement test results in English, reading, and/or math to the Counseling/Testing Center to determine whether it is advisable to complete additional placement testing at Santa Ana College. Placement test information from other colleges must include: your name, name of the test(s), the raw score(s), and test date(s). Test scores for English are valid for two years. Test scores for Math are valid for one year.
- Make an appointment to see a counselor by calling the Santa Ana College Counseling Center at 564-6100.

NEW STUDENT

You are a new student if you have never enrolled in college credit classes at SAC OR SCC. File an application in person or online, www.sac.edu.

MATRICULATION INFORMATION FOR NEW STUDENTS

- The matriculation program consists of a program of assessment, orientation, and academic advisement for students who plan to do any of the following:
 - accumulate 15 units or more,
 - enroll in an English or Math course,
 - work toward an Associate degree, occupational certificate, transfer program to a four-year university, or new career.
- Students with bachelor's degrees or higher are exempt from matriculation.
- Students who are unsure whether they should complete the matriculation program should contact the Counseling Department at Santa Ana College, 564-6100 or go online to www.sac.edu/online_counseling.

NEW STUDENT REGISTRATION

- New students receive appointments to register on a first-come, first-serve basis. All new students to SAC are encouraged to complete matriculation services (testing, orientation, and advisement). **Failure to complete testing may change your registration date.**
- **!** To complete placement testing (assessment), you must first file your admission application.
- Upon completing testing, students will be given an appointment to attend an orientation and advisement session with a counselor. Students will receive their test results and their appointment to register after completing orientation and advisement. The first date of new student registration is January 22. Please refer to page 13 for further testing information.

New matriculation students can register online! See page 9 for information.

... REGISTRATION ...

REGISTRATION (continued)

REGISTRATION BY APPOINTMENT

FORMER STUDENTS AND OTHER NEW STUDENTS

- Registration for former and other new students not participating in the above matriculation procedures is controlled by the Registration Appointment. Students are issued a date and time to register after submitting an application.
- You may apply and enroll online – www.sac.edu
- Registration appointments are issued on a first-come, first-serve basis.

LATE REGISTRATION and ADD PERIOD (Feb. 11 to Feb. 22)

- **Instructor signature is required on all adds after the semester begins.**
- ADD/DROP forms to petition the instructor are available in the Admissions/Records Office. After completion, submit forms to the Registration Area in U-102 with enrollment fee payment, if required, for each class added.
- The computer or telephone may be used to drop classes through the established drop date (75% of the way through a class). To avoid fees, drop by February 22, 2008 for full-term classes.
- **No add cards with instructor signatures will be accepted after February 22, 2008 for full-term classes.**

To Avoid Fees, drop online or by telephone November 26 – February 22

WAIT LIST RULES

For most courses, you may place your name on a Wait List for one class section. You will receive a priority number for your position on the list.

1. You must meet the corequisites or prerequisites of the course.
2. You cannot Wait List for a class that would cause time conflicts with your existing class schedule or future added classes.
3. You can only be on 1 (one) Wait List per class section. Adding yourself to a 2nd (second) Wait List will automatically drop you from the first Wait List.
4. If you are on a Wait List when the class meets for the first time, **you must attend the first class meeting** to see if there is available space. If you do not attend the first class meeting, you lose your place on the Wait List and another student will be added.

PAY FEES – **Avoid having a hold placed on your records!**
Fees are due immediately upon registration.

The last day to pay fees is the Thursday before the semester begins.

Failure to pay fees will result in an administrative hold on your student record.

The consequences of this hold could:

- affect ability to register for future classes
- prevent release of official transcripts.

Enrollment fee waivers are available. Forms can be obtained at the Financial Aid Office.

LOCATIONS & TIMES FOR REGISTRATION BEGINNING NOVEMBER 26.

Santa Ana College

Johnson Center,
Room U-102

Monday–Thursday, 10am–6:45pm

Friday, 10am–3:45pm

(Closed Dec. 24–Jan. 1 during holiday break)

STUDENT RESPONSIBILITY TO DROP CLASSES AFTER SEMESTER BEGINS

Students who have enrolled and paid for classes and decide not to attend must drop classes before Friday, February 22, to avoid fee charges. Classes dropped after that date will appear on the student record with a “W” grade. **You will not be automatically dropped from your classes after the semester begins. You may drop classes online or by telephone.** After the second week, you will incur a financial obligation to the college and an administrative hold will be placed on your student record until fees are paid. (Any unpaid fees as a result of a dishonored check or other outstanding debt will be handled in the same manner.)

- You may drop classes online or by telephone.
- Drop classes by FRIDAY, FEBRUARY 22 to avoid Academic Hold and “W” grade!
- Even if you do not attend the class, after the semester begins, you owe the fees unless you drop the class before Friday, February 22!

ONLINE REGISTRATION & RECORDS

Check the college website at www.sac.edu for:

- Online registration
- Online counseling
- Open classes (course availability)
- View your class schedule
- Grades from previous semester
- Admissions and Registration information
- Print or view unofficial transcripts
- Request official transcripts online
- Account summary
- Change your PIN number or update your address, major, or educational goal
- Add or drop classes
- Pay fees online immediately

[More Registration Information . . .](#)

ONLINE & TELEPHONE REGISTRATION

SPRING 2008 REGISTRATION

is available for continuing students enrolled at SAC during Spring 2007 or Fall 2007. The priority system for online and telephone registration is based on units earned at SAC/SCC only.

Follow instructions and steps on this and the next two pages to register online or by telephone, and check pages 14 and 15 for other helpful and important registration information.

Online counseling now available!
www.sac.edu/online_counseling

HALF DAY PERIODS FOR FALL REGISTRATION ONLINE OR BY TELEPHONE (for continuing students)

UNITS COMPLETED	PERMIT DATE & TIME	UNITS COMPLETED	PERMIT DATE & TIME
DSPS	11/26/07 starts at 7am	22 – 23	12/7/07 starts at 7am
EOPS	11/27/07 starts at 7am	20 – 21	12/7/07 starts at 3pm
80+	11/28/07 starts at 7am	19.....	12/10/07 starts at 7am
70 – 79	11/28/07 starts at 3pm	17 – 18	12/10/07 starts at 3pm
65 – 69	11/29/07 starts at 7am	14 – 16	12/11/07 starts at 7am
60 – 64	11/29/07 starts at 3pm	12 – 13	12/12/07 starts at 7am
55 – 59	11/30/07 starts at 7am	10 – 11	12/13/07 starts at 7am
51 – 54	11/30/07 starts at 3pm	8 – 9	12/13/07 starts at 3pm
45 – 50	12/3/07 starts at 7am	7.....	12/17/07 starts at 7am
39 – 44	12/3/07 starts at 3pm	5 – 6	12/17/07 starts at 3pm
37 – 38	12/4/07 starts at 7am	4.....	12/18/07 starts at 7am
34 – 36	12/4/07 starts at 3pm	3.....	12/18/07 starts at 3pm
30 – 33	12/5/07 starts at 7am	1 – 2	12/20/07 starts at 7am
27 – 29	12/5/07 starts at 3pm	0.....	12/20/07 starts at 3pm
26.....	12/6/07 starts at 7am	New Matriculation.....	1/14/08–1/21/08
24 – 25	12/6/07 starts at 3pm	Non Matriculation	1/22/08–2/8/08

REGISTRATION STEPS AND PROCEDURES

1	Use the computer or telephone system during the early registration period. The online or telephone registration schedule is shown above.
2	<p>FOR CONTINUING STUDENTS</p> <ul style="list-style-type: none"> • Early registration begins November 26 and continues through December 20. • Telephone and Online Registration Hours are Monday–Thursday, 7am–9pm; Friday, 7am–5pm
3	Before you register, complete the worksheet for Spring Registration on page 10. Follow the sample worksheet, completing all items.
4	<p>FEES ARE DUE WHEN YOU REGISTER! PAY IMMEDIATELY BY PHONE! (714) 564-6400</p> <p>PAY IN PERSON at the Area Campus Registration Locations listed in Center Insert. OR BY MAIL: Do not send cash! Make check payable to “RSCCD” and write your Student I.D. on the check. Mail check to Santa Ana College, ATTN: Cashier’s Office, 1530 W. 17th Street, Santa Ana, CA 92706. Call (714) 564-6965 for questions regarding fee payment.</p>
5	Students enrolling by computer or telephone owe fees immediately, or a hold may be placed on your records prior to the semester start. YOU MAY DROP BY TELEPHONE OR ONLINE.
6	Verification of enrollment, parking permit, and receipt will be provided at the place of fee payment, or sent by mail if fee payment is made by telephone or mail. If you do not receive verification within 2 weeks, call the Cashier’s Office, (714) 564-6965.



ONLINE REGISTRATION STEP-BY-STEP

1

Log onto
www.sac.edu (SAC)

2

Click on *Register Online*
located on the top right
corner.

3

Click on the tab entitled
Online Records to register.

4

For Online Records,
enter your Student ID
123456789 (for example)
(can use your social security number to
access I.D – it will be hidden)
then enter your PIN Number
0688 (for example)
(your PIN = birth month + last 2 digits of birth
year—for example June 1988 = 0688)
then click on Enter
when finished.

5

Under Registration, click
on Course Registration.

6

Choose correct term
→ **SPRING**
SUMMER
FALL

There are two ways to add a class:

by entering a ticket number or
by “looking up” the class.

When you are ready to register
for a specific class,
click the Add Now box.

7

If the class is full, the computer
will ask you if you want to be
on the Wait List.
If yes, click the Wait List Box.
If you do not wish to be on a
wait list, click on Cancel.

To drop a class,
click on the Drop Now box.

Suggestion:
Remember to pay fees
and print a copy if possible.

8

PAY FEES – Pay with a credit
card immediately after verifying
class schedule.

9

Once you are finished adding
or dropping your class(es),
remember to click on LOGOUT.
Logout is located in the upper
left hand corner of the screen.

?

Registration questions?
Call (714) 564-6019 (SAC)
(after November 26, 2007)
Counseling questions?
Call (714) 564-6100 (SAC)

FEES AND REFUNDS

STUDENT FEES

ENROLLMENT FEE

The Enrollment Fee is \$20.00 per unit, with no maximum. Payment is required of all students upon registering for classes. This fee is subject to change.

NON-RESIDENT TUITION

Non-resident Tuition is \$183.00 per unit. Tuition is required of international and out-of-state students, payable at registration. Refer residency questions to the Admissions Office.

HEALTH FEE

The Health Fee is \$14.00 for Fall semester, payable at registration. This fee is mandatory for SAC and SCC campus classes.

STUDENT SERVICE FEE

A Student Service Fee of \$7.50 is payable at registration for classes at SAC. The fee includes: 1) \$2.50 for photo ID used for library, student and instructional services; and 2) \$5.00 for college activities. Photo ID and semester validation available at registration or the Cashier's Office, room U-218 at Santa Ana College. Payment of this fee is optional. See page 97 for a list of fee benefits.

PARKING FEE

Parking Permits are \$16.00 and may be purchased at registration. A permit is required to park on campus at SAC and SCC only (Monday-Friday). Only one permit is necessary for students who attend both colleges. Motorcycles are exempt in designated parking areas.

MATERIALS FEE

A Materials Fee may be required for a course. Check class listings in this publication for specific fees.

ESTIMATED COST

ENROLLMENT FEE				
\$20	X	_____	=	_____
		units		
NON-RESIDENT TUITION				
\$183	X	_____	=	_____
		units		
HEALTH FEE (\$14 for SAC & SCC campus classes)			=	_____
STUDENT SERVICE FEE (OPTIONAL) (\$7.50 for SAC or SCC campus classes)			=	_____
PARKING PERMIT (OPTIONAL \$16 fee)			=	_____
MATERIALS FEES			=	_____
TOTAL			=	_____

REFUNDS

Refunds (excluding non-resident tuition) will be issued in the following manner: credit refund to card for all credit card payments, cash refund for cash payments, cash refund for check payments after 14 calendar days from the date of cash register receipt for full semester classes. Short term classes have refund deadlines of one week or less.

Refund of Enrollment, Health, Parking, and Student Service Fees

Students who withdraw from full semester classes by Friday, September 7, or by 10% of a course less than a semester in length, may request a 100% refund.

Refunds for eligible students should be requested in person by visiting the registration area or the Cashier's Office at SAC. All original receipts must be presented at the time of request for refund. REFUNDS ARE NOT ISSUED BY MAIL.

REFUND OF Non-Resident Tuition

Students who withdraw from full-semester classes by Friday, September 7, may request a 100% refund. Students withdrawing after that date are not eligible for a refund.

Refunds for International Students may be requested in person by visiting the Cashier's Office at Santa Ana College.

Refunds will be issued in the following manner: credit refund to card for all credit card payments, cash and check payments will be refunded by check after a five to six week waiting period.

NOTICE

DISHONORED CHECKS

A \$25.00 fee will be charged for a check returned for any reason. In addition, an administrative hold will be placed against your student records and a class stop may be issued. Payment for dishonored checks may be made by cash, cashier's check or money order only at the Cashier's Office at SAC, room U-218, or the Cashier's Office at SCC.

Fees are due immediately upon registration.

The last day to pay fees is the Thursday before the semester begins.

Failure to pay fees will result in an administrative hold on your student record.

The consequences of this hold could:

- affect ability to register for future classes
- prevent release of official transcripts.

FINANCIAL ASSISTANCE INFORMATION & FEE WAIVER FORM ARE LOCATED BETWEEN THE SAC SECTION AND THE SCC SECTIONS OF THIS BOOK

FEE PAYMENT OPTIONS

Payment by check, Visa, Mastercard, or Discover Card are accepted for payment by mail, by drop box, or in person. Questions? Call 564-6965.



1. ONLINE

- Payment by credit card via the college website.
- Santa Ana College: www.sac.edu

2. TELEPHONE

Pay by telephone (714) 564-6400



3. BY MAIL

Send to: Santa Ana College Cashier's Office, 1530 W. 17th Street, Santa Ana, CA 92706.



4. IN PERSON

Santa Ana College: Fee payments are made in the Student Business Office, room U-218 in the Johnson Center.

TESTS – PLACEMENT

PLACEMENT TESTING

WHAT is testing?

To assist you in successfully reaching your education goals, we request that most students complete assessment or placement testing in English, reading and math. This enables us to counsel you as to the appropriate English, reading and math courses you should take.

For English there are two tests. The College Test of English Placement (CTEP) is for students who have studied English and/or ESL (English as a Second Language) in school for at least seven years or who use English frequently on a daily basis. The other test, the Test of English Language Development (TELD) is for students who have not studied English and/or ESL in school for at least seven years or who do not use English frequently on a daily basis. Students taking the TELD will be referred to ESL/EMLS classes. Students who take the wrong test may be placed in a class that is not right for them. By the time you and the teacher realize that you are in the wrong class, it may be too late to register for the appropriate class.

The Math Diagnostic Testing Project (MDTP) has four different levels. Choose the level you feel you are best prepared for. Sample questions for each test are available in the Testing Center and in the math study center.

WHO should complete testing?

Any student who: plans to accumulate 15 or more units at RSCCD; plans to enroll in an English, reading, or math course; plans to complete an Associate degree, certificate, or transfer to a four-year university; is formulating career interests, plans or goals; is preparing for a new career, is undecided about educational goals, or who would like more information on present skills and abilities or help from a counselor in selecting appropriate classes.

WHAT if I already tested?

Your test scores in **English** are valid for **two years**. If you tested more than two years ago and have not taken an English or ESL class at SAC or SCC you must test again. If you wish to retest you will be required to wait one year.

Reading scores will remain valid indefinitely. If you wish a retest you will be required to wait one year.

Your test scores in **Math** are good for **one year**. If you tested more than one year ago and have not taken a math class at SAC or SCC you must retest. You may take a different level math test at any time. You may not take the same level math test more than once in any semester.

Continuing students who need to retest should schedule an appointment during priority testing. You may not retest if you have taken the CTEP (English and Reading) test within the last year, the TELD (ESL) within the last two years, or the Math test within the last 6 months for the same math level.

WHAT if I tested at another college?

If you tested within the last two years in English, last year in math, or anytime in reading, bring official copies of placement test results in English, reading, and/or math to the Testing Center (L-221) at Santa Ana College, as soon as possible to determine whether it is necessary to complete testing at SAC or whether your eligibility can be verified and you can be cleared for registration. Placement test information from other colleges must include: your name, name of the test(s), the raw score(s), and test date(s).

ESL test scores from other institutions are not accepted. In addition, ESL students who have completed ESL credit courses at other colleges, and are still in need of additional ESL or EMLS instruction, must also take

WHAT if I tested at another college? (continued)

the placement test at RSCCD. This is done so that we can determine which of our courses best meet your needs.

If your test scores are over two years old in English, or one year old in math, or if you are applying for a special program which requires testing at SAC, you will need to re-test.

HOW do I complete testing?

1. New students must first apply to the college.
2. Students who apply early will be referred to the Testing Center to schedule a testing appointment. Paper and pencil testing appointments are scheduled for CTEP, Math and TELD tests. **Computer based CTEP/TELD and Math tests are available on a walk-in basis at Santa Ana College.** Priority testing is conducted in the Testing Center, L-221. Call 564-6147 for an appointment.
3. Continuing students who have not tested or who need to retest should complete testing during priority testing.
4. Regular testing for the Spring semester begins February 11, 2008. You may schedule a regular testing appointment online at www.sac.edu/eSARS_SAC/TESTCTR/eSARS.asp or by calling the Testing Center at 564-6147.
5. After you complete testing, you will be directed to attend orientation and advisement with a counselor where you will receive your test results and other information about college requirements, courses, and programs. You may register upon completing testing, orientation, and advisement.

WHY should I do this?

1. By completing testing, orientation, and advisement we will be able to assist you in planning a course of study based on your academic abilities and interests.
2. The California Community Colleges have adopted this matriculation effort as a statewide requirement.
3. If there are other circumstances that should be considered in recommending your enrollment into certain courses, please contact the Counseling Center at 564-6100 or the Disabled Student Services Program, 564-6295.

RIGHT TO APPEAL

Students who feel that they have been treated in a discriminatory manner, or would like to appeal their recommended placement level may file a complaint about any aspect of the college's matriculation program with the matriculation coordinator. Call 564-6078.

FIRST CLASS MEETING

Make sure you attend the first class meeting!

Attendance at the first meeting of a class is advised because of enrollment demands. Any student not reporting to the first class meeting may be dropped from the roll sheet.

MORE TEST INFORMATION AND TESTING SCHEDULES . . .

TESTS – PLACEMENT & FINAL EXAMINATIONS

SANTA ANA COLLEGE SPRING 2008

Placement Testing Schedule

- **ELIGIBILITY FOR TESTING:** 1) Must have submitted a completed application to the college, 2) Have not taken the CTEP (English and Reading) test within one year, 3) The TELD (ESL) test within two years or 3) The Math test within 6 months for same math level
- Please arrive 30 minutes early.
- Orientation and advisement including test results follow testing. An appointment will be scheduled for you when you complete testing.
- Picture I.D. is required.
- All students must have a testing appointment. To schedule an appointment for the following dates listed below you may go to www.sac.edu/esars_sac/testctr/esars.asp or call the Testing Center , 564-6147.
- All tests will be given in the Testing Center, L-221.

DATE	CTEP (Eng/Read) – Rm L-221	MATH – Rm L-221	TELD (ESL) – Room L-221	MATH – Rm L-221
Monday, January 7	9:00 am & 6:00 pm	10:30 am & 7:30 pm		
Tuesday, January 8	9:00 am & 6:00 pm	10:30 am & 7:30 pm		
Wednesday, January 9			1:00 pm & 6:00 pm	2:00 pm & 7:00 pm
Monday, January 14	9:00 am & 6:00 pm	10:30 am & 7:30 pm		
Tuesday, January 15			9:00 am & 6:00 pm	10:00 am & 7:00 pm
Wednesday, January 16	1:00 pm & 6:00 pm			
Tuesday, January 22	9:00 am & 6:00 pm	10:30 am & 7:30 pm		
Wednesday, January 23	1:00 pm & 6:00 pm			
Thursday, January 24			1:00 pm & 6:00 pm	2:00 pm & 7:00 pm
Monday, January 28	9:00 am & 6:00 pm	10:30 am & 7:30 pm		
Tuesday, January 29			9:00 am & 6:00 pm	10:00 am & 7:00 pm
Wednesday, January 30				
Thursday, January 31	1:00 pm & 6:00 pm			
Monday, February 4	9:00 am & 6:00 pm	10:30 am & 7:30 pm		
Tuesday, February 5	9:00 am & 6:00 pm	10:30 am & 7:30 pm		
Wednesday, February 6			1:00 pm & 6:00 pm	2:00 pm & 7:00 pm

During the regular semester, beginning February 11, 2008, the Testing Center will offer paper and pencil testing on a weekly basis as follows:
 The CTEP will be given every Monday at noon and Tuesday at 6:00 pm. The TELD will be given on alternate Mondays at 6:00 pm and Tuesdays at 11:00 am.
 A computer based CTEP, TELD and Math test is available on a walk-in basis.

CHEMISTRY 219 ADMISSIONS TEST

The Chemistry 219 Admissions Test takes 45 minutes. Students do not need an appointment. **Picture identification is required.** All tests will be held at the **Testing Center**, Room L-221 on the second floor of the library building on the Santa Ana Campus. The test will be given on the first Thursday of each month when school is in session, and on January 24, 2008 and February 7, 2008 at 1:00 pm and 5:00 pm.

ABILITY TO BENEFIT

Testing is offered every other Tuesday at 10:00 am during the regular semester by appointment only.

COMPUTER-BASED TESTING

If you plan to enroll in English, Reading, ESL or Math next semester you should test NOW! Computer-based testing is offered whenever paper/pencil tests are not scheduled. You do not need an appointment, however, you should call to check when walk-in times are offered.

SANTA ANA COLLEGE SPRING 2008 Final Examination Schedule

Final exams will be given during the last week of the semester during regular scheduled class hours. The last day of instruction is Sunday, June 8. Final exams may be given during one class session or a combination of class sessions, as designated by the instructor; check with individual instructors for exact date.

SEMESTER GRADES ARE DUE IN THE ADMISSIONS OFFICE ON TUESDAY, JUNE 10, 2008.

POLICIES, NOTICES, & GRADES

DISABLED STUDENTS POLICY

The District will make reasonable accommodations for individuals with disabilities. For special assistance with programs and services, contact the Associate Dean of Disabled Students Programs and Services at (714) 564-6264. See page 89 of this schedule for more information.

NONDISCRIMINATION POLICY

Rancho Santiago Community College District provides opportunities for the pursuit of excellence through educational programs and services primarily for college district residents. The purpose of these programs and services is to enhance the quality of human life by providing public access to college education without regard to race, ethnic or national origin, sex, age, disability, sexual orientation, or prior educational status or any other unreasonable basis for discrimination. The lack of English language skills will not be a barrier to admission and participation in vocational education programs.

The District complies with all state and federal rules and regulations and does not discriminate on the basis of race, color, national origin, gender or disability. This holds true for all district employment and opportunities. Harassment of any employee/student with regard to race, color, national origin, gender or disability is strictly prohibited. Inquiries regarding compliance and/or grievance procedures may be directed to the Districts Title IX Officer and/or the Section 504/ADA Coordinator. Title IX Officer/Section 504/ADA Coordinator: John Didion, 2323 N. Broadway, Santa Ana, (714) 480-7489

POLÍTICA NO DISCRIMINATORIA

El "Distrito del Rancho Santiago Community College" proporciona, principalmente a los residentes de su distrito, oportunidades a fin de alcanzar metas de excelencia por medio de sus programas educativos y de otros servicios. El propósito de estos programas y servicios es mejorar la calidad de la vida humana haciendo accesible la educación universitaria al público en general, sin prestar atención a su raza, origen étnico o nacional, sexo, edad, insuficiencias o incapacidad física, preferencia sexual, previa situación educacional, o cualquier otra base irrazonable de discriminación. La falta de habilidad en el lenguaje inglés no será una barrera a la admisión o participación en el programa de educación vocacional.

El Distrito cumple con los reglamentos y leyes federales y estatales y no discrimina en base a raza, color, descendencia nacional, sexo o discapacidad. Esto también se aplica a todos los estudiantes que están interesados en participar en los programas educacionales y/o en actividades escolares que sean extracurricular. El hostigamiento en contra de cualquier empleado/estudiante con respecto a su raza, color, descendencia nacional, sexo o discapacidad está estrictamente prohibido. Las preguntas sobre el cumplimiento de estas leyes o del proceso de quejas pueden ser dirigidas al Oficial del Distrito a cargo del cumplimiento del Título IX y al Coordinador de la Sección 504/ADA: John Didion, 2323 N. Broadway, Santa Ana, (714) 480-7489

CHÍNH SÁCH KHÔNG KỶ THỊ

Viện Đại Học Cộng Đồng Rancho Santiago tạo cơ hội tiên thân qua các chương trình và dịch vụ giáo dục, chủ yếu cho mọi người cư ngụ trong khu học chánh của trường. Mục đích của các chương trình và dịch vụ này nhằm tăng phẩm chất của đời sống con người bằng cách cung ứng cho quần chúng có hội để theo học bậc đại học, mà không phân biệt chủng tộc, màu da, quốc tịch, nam nữ, tuổi tác, tật nguyền, sở thích sinh lý, hoặc quá trình học vấn, hoặc bất cứ lý do kỳ thị vô lý nào khác. Khả năng Anh ngữ kém cũng không làm trở ngại đến việc được nhận học và tham dự các chương trình học vấn huân nghệ của trường. Mọi thắc mắc về sự áp dụng chính sách này xin liên lạc với Phó Viện Trưởng Đặc Trách Dịch Vụ Sinh Viên và Cộng Đồng.

OFF-CAMPUS FIELD TRIPS POLICY

Throughout the semester/school year, the District may sponsor voluntary off-campus extracurricular field trips/excursions. If you choose to participate, be advised that pursuant to California Code of Regulations, Subchapter 5, Section 55450, you have agreed to hold the District, its officers, agents and employees harmless from any and all liability or claims which may arise out of or in connection with your participation in the activity.

REGISTERED SEX OFFENDER INFORMATION

Information concerning registered sex offenders can be obtained from: the Santa Ana Police Department, 3rd Floor Lobby, 60 Civic Center Plaza, Santa Ana, on Mondays through Fridays, from 9am to 12pm and from 1-4pm; and from the Orange Police Department, Youth Services Bureau (Rene Nicholson), 1107 North Batavia Street, Orange by calling 714-744-7311 for an appointment.

Sex offenders are required to register with the police in the jurisdiction in which they reside and at institutions of higher learning if they are students there or if they work there as employees, contractors, or volunteers. Sex offenders who may be required to register should do so at the Santa Ana Police Department if attending Santa Ana College or at the Orange Police Department if attending Santiago Canyon College.

SEXUAL HARASSMENT POLICY

It is the policy of the Rancho Santiago Community College District to provide an educational, employment and business environment free of unwelcome sexual advances, requests for sexual favors, and other verbal or physical conduct or communications constituting sexual harassment, as defined and otherwise prohibited by State and Federal law. The Rancho Santiago Community College District forbids any form of sexual harassment. Prompt disciplinary action will be taken against any student or employee engaging in sexual harassment. If you feel that you have been the victim of sexual harassment please contact the Human Resources Dept. at (714) 480-7489, or the Associate Dean of Student Development at Santa Ana College at (714) 564-6211.

STUDENT CODE OF CONDUCT

Students enrolled in Santa Ana College instructional programs assume an obligation to obey state law (California Education Code, California Administrative Code, Title V), district rules (policies of the Board of Trustees), and all civil and criminal codes governing the conduct of students. Please see the current SAC Catalog for specific guidelines for student conduct.

TRANSPORTATION POLICY

Some classes may be conducted off campus. Unless you are specifically advised otherwise, you are responsible for arranging your own transportation to and from the class site. Although the District may assist in coordinating the transportation and/or recommend travel times, be advised that the District assumes no liability or responsibility for the transportation, and any person driving a personal vehicle is **NOT** an agent of the District.

COLLEGE-CREDIT PROGRAMS

The Rancho Santiago Community College District offers major college-credit programs in Santa Ana and Orange. Classes offered at Santa Ana College are identified as "SAC." Santiago Canyon College classes are identified with "SCC". Please refer to the list of RSCCD facilities for specific class locations at other sites.

COURSE ARRANGED HOURS

Students are obligated to carry out hours by arrangement in designated facilities, which are normally available from 8:00 a.m. to 10:00 p.m., Monday through Thursday, and from 8:00 a.m. to NOON on Fridays.

COURSE OPEN ENROLLMENT

Unless specifically exempted by statute, every course wherever offered and maintained by the District is fully open to enrollment and participation by any person who has been admitted to the college and meets the course prerequisites established in accordance with Title V.

COURSE REPETITION

WHEN MAY COURSES BE REPEATED?

SUBSTANDARD WORK

A student who has earned a grade of D, F, NC (No Credit) or W in a non repeatable class may repeat that course once to improve their grade. A student who has received two substandard grades must petition and receive the Division Dean's approval to repeat the course for the third time. A student who has received two W's must petition and receive approval from their counselor to repeat the course for the third time.

REPEATABLE COURSES

When a class is identified as repeatable in the Class Schedule, that course may not be repeated more than three times regardless of the grades received. No portion of the class may be repeated to improve a student's grade point average.

VARIABLE UNIT COURSES

When a course is designated as repeatable and is also variable unit, the number of repeats dictates how many times the course may be enrolled in for credit. A variable unit course which is not designated as repeatable may be registered for until the maximum number of units has been attempted. No portion of the class may be repeated to improve your grade point average.

OTHER REPETITIONS – A & G PETITION PROCESS

Any repetition of a class beyond the specified limits previously specified must be petitioned in the Admissions Office. Criteria that can be considered is a significant lapse of time (usually 2 years or more) since the student previously completed the course, or in the event of documental extenuating circumstances (accident, illness, injury, or other circumstance beyond the control of the student).

WITHDRAWAL POLICY

While an instructor may drop a student, it is the student's responsibility to officially withdraw from a class in which they stop attending.

For a semester length course, students must drop by Friday, February 22 to not receive a "W" grade and not be responsible for registration fees. Any student who is officially enrolled in a semester length class beyond February 22, 2008 is financially responsible for all registration fees associated with that enrollment, even if the student does not attend the class. Time periods for short term classes are different. Please check with the Admissions Office for deadlines.

Students may drop and receive a "W" grade between February 23 and May 9, 2007. Student enrolled in classes that are less than semester length, must withdraw before the 75% point of the class. Neither the student or instructor may initiate a withdrawal after the deadline, and students officially enrolled in a class beyond the drop deadline must receive a grade other than "W."

FAMILY RIGHTS AND PRIVACY ACT

As required under the provisions of the Family Rights and Privacy Act of 1974, Santa Ana College will make public without student consent only certain directory information. This information consists of the following:

- student's name, city of residence, major field of study;
- participation in officially recognized activities and sports;
- weight, height, and age if a member of an athletic team;
- dates of attendance, degree and awards received;
- the most recent previous educational institution or agency attended by the student.

A student may request the Admissions and Records Office to withhold this information. Such request can be in writing and submitted each semester, or the student may do this privacy block in person. Bring a photo ID!

CREDIT/NO CREDIT (Pass/Fail)

Credit/No Credit petitions for full semester classes must be received in the Admissions Office by March 14, 2008. **Credit/No Credit petitions for classes less than a semester in length must be submitted before 30% of the class expires. Credit/No Credit courses may NOT be taken in the student's major field and a maximum of 12 units of credit/no credit are allowed toward a degree program.** Credit/no credit does not include credit by examination. Deadlines for CR/NC forms are final! A&G petitions will not be approved.

TRANSCRIPTS

Official Transcripts of previous high school and college work should be filed with the Admissions Office by students pursuing a degree.

TEST SCORES

If enrolling in English, Reading, and/or Math, bring official copies of placement test results from other colleges to the Testing Center (L-225) at Santa Ana College. They will determine if it is advisable to complete additional placement testing at SAC. Placement test information from other colleges must include: your name, name of the test(s), the raw score(s), and test date(s). Test scores in English or ESL are valid for two years. **If you tested more than two years ago for English/ESL, you may need to retest.** ESL test scores from other institutions are not accepted. Math test scores are valid for one year only.

FIRST CLASS MEETING

Make sure you attend the first class meeting!

Attendance at the first meeting of a class is advised because of enrollment demands. Any student not reporting to the first class meeting may be dropped from the roll sheet.

GRADES DUE AND AVAILABLE

Final course grades are available:

- online, by visiting the websites at www.sac.edu (SAC)
- by telephone (see procedures in the box on page 16)

Instructor grade delivery and student grade availability dates are as follows:

- SPRING semester grades will be available after Tuesday, June 10, 2008.
- FALL semester grades are due in the Admissions office on Tuesday, December 18, 2007.

Once the instructor submits grades to admissions, students can view grades the next day using the online records system.

DISTRICT SAFETY AND SECURITY

The District Safety Department provides 24 hour services to both Santa Ana College and Santiago Canyon College, and their sites and centers. At SAC the office is at the X building and the telephone number is 714-564-6330. At SCC, the district safety and security office is at the U building and the phone number is 714-628-4730. Persons wanting to call the office may also do so at SAC, SCC and at the Centennial Education Center may use the yellow call-boxes on those campuses. After hours, from 11pm to 7am, Mon-Fri, the district-wide number for district safety and security services for all campuses is 714-564-6333.

RSCCD has a reputation for maintaining safe campuses, where staff, students and faculty can work and study without fear for their personal safety or property. This is, in part, a result of everyone working together to create an atmosphere that is safe and conducive to learning. All crimes or serious incidents that occur on campus should be reported to the district safety and security department. Crime report logs for the district are maintained and available for review at the district safety office at Santa Ana College.

RSCCD TOTAL CRIME STATISTICS ON CAMPUS

Includes both Santa Ana College and Santiago Canyon College All sites and centers

CRIME	2004	2005	2006
Motor vehicle theft	18	25	9
Larceny from vehicle	45	26	19
Burglary from building	5	3	1
Robbery	1	3	3
Aggravated assault	2	0	1
Murder	0	0	0
Forcible sex	0	3	1
Non-forcible sex	0	0	0
Liquor law violation	3	1	2
Drug abuse violation	3	3	4
Weapons violation	0	0	0
Arson	0	0	0
Grand theft (over \$400)	11	9	11
Hate crimes	0	0	0
Bomb threat	0	0	0

WWW.SAC.EDU



**RECORDS, TRANSACTIONS,
AND INFORMATION
AVAILABLE ONLINE
at **WWW.SAC.EDU****

- Open classes (course availability) “Real Time”
- Grades
- Address, major, and educational goal update—*keep address current*
- Detailed Catalog information—updated monthly (www.sac.edu)
- Class Schedule information
- Unofficial transcripts
- Request official transcripts online—must pay with a credit card. (Free transcripts not available)
- Change your pin number—protect your privacy!
- Register online: add and drop classes
- Pay fees online with a credit card



**A TOUCHTONE
TELEPHONE SYSTEM
WILL PROVIDE YOUR GRADES**

- For final course grades only. (Mid-term grades are not available by telephone)
- Fall grades will be available after January 7, 2008.

TELEPHONE GRADE ACCESS PROCEDURES

1. **Call a Telephone Registration Grade Access Number**
- **OR** -
2. **Enter the Grade Action Code**
press the Grade Code
press the Semester Code (FALL), (SPRING), **OR** (SUMMER), then press
3. **Enter your student ID Number, then press**

(up to 9-digit perm number)
4. **Enter your pin number or last 2 digits of your birth month & birth year, then press #**
(EXAMPLES: JAN 1, 1986 = 0186)
5. **Is your name correct?** YES NO
6. **To list grades, enter**
7. **To EXIT Telephone Registration and terminate call, enter**

Can't find the class you need?

**It may be waiting for you at
Santiago Canyon College!**

**View SCC's class schedule at
www.sccollege.edu/schedule**

SCC's class schedule is included in this booklet.

Hurry! Class sizes are limited.

SCHEDULE OF CLASSES

HOW TO READ THE COLLEGE CREDIT CLASS SCHEDULE

Check the course title and number carefully and be sure to note where the class meets. Many are at different campuses which may affect your time schedule and selection of classes. A key to the abbreviations for site locations is on this page.

<p>Course Title and Number</p> <p>Supplemental info/notices</p> <p>Ticket Number</p>	<p>BUSINESS APPLICATIONS 147, INTRODUCTION TO WINDOWS</p> <p>The fundamentals of graphical user interface including using Help, launching applications, managing files and folders. Students will use Windows Help, with My Computer and Explorer. Additional accessories include Control Panel, WordPad, Character Map, and Communications.</p> <p>\$2.00 material fee required for this course at registration. (Software Utilized: Windows XP)</p> <table border="0"> <tr> <td>1214703</td> <td>8:00-9:20</td> <td>MW</td> <td>Crowley D</td> <td>SAC A-208</td> <td>8/28-10/21</td> </tr> <tr> <td>1214701</td> <td>5:30-6:50pm</td> <td>MW</td> <td>Nguyen M</td> <td>SAC A-222</td> <td>10/23-12/17</td> </tr> <tr> <td>1214702</td> <td>6:30-9:35pm</td> <td>F</td> <td>Ali W</td> <td>SAC A-222</td> <td>9/2-10/21</td> </tr> </table>	1214703	8:00-9:20	MW	Crowley D	SAC A-208	8/28-10/21	1214701	5:30-6:50pm	MW	Nguyen M	SAC A-222	10/23-12/17	1214702	6:30-9:35pm	F	Ali W	SAC A-222	9/2-10/21	<p>1.5 UNITS</p> <p>Units of Credit</p> <p>Course Description (see page 91 for information about prerequisites & advisories)</p> <p>Course Begin and End dates for classes that are not standard full semester</p>
1214703	8:00-9:20	MW	Crowley D	SAC A-208	8/28-10/21															
1214701	5:30-6:50pm	MW	Nguyen M	SAC A-222	10/23-12/17															
1214702	6:30-9:35pm	F	Ali W	SAC A-222	9/2-10/21															
	<p>Time</p> <p>Day(s)</p> <p>Instructor</p> <p>Site Location (see this page for a complete list of sites)</p> <p>Room</p>																			

An ICON next to a listed class indicates a special offering:



HONORS COURSES – Look for the Honors course torch symbol in the schedule or check the SAC listing on page 19.



ONLINE CLASSES – Look for the Online class symbol in the schedule or check the complete list on pages 21–24.



TV CLASSES – Look for the TV class symbol in the schedule or check the complete list on page 25.



OFF CAMPUS FIELD TRIPS – Look for the Field Trip symbol for classes that include field trips and read the policy on page 14.



FUTURE TEACHERS – Content of interest to future teachers



WEEKEND CLASSES – Classes offered Friday evenings, Saturday, and Sunday or check the complete list on page 18.

LOCATIONS

Index of class locations at Instructional Centers in the Santa Ana College service area

CARE – Carehouse Convalescent Hospital
1800 Old Tustin Avenue, Santa Ana

CDC – Santa Ana College
Child Development Center
1720 W. 17th Street, Santa Ana

CEC – Centennial Education Center
2900 W. Edinger, Santa Ana, (714) 564-5000

CJTC – Orange County Sheriff's
Regional Training Academy
15991 Armstrong Avenue, Tustin

DMC – Digital Media Center
1300 S. Bristol, Santa Ana

FVRH – Fountain Valley Regional Hospital
17100 Euclid, Fountain Valley

JPTC-CN – Joint Powers Training
Facility—Central Net
18301 Gothard, Huntington Beach

OCDE – Orange County Department
of Education
5700 Kalmas, Costa Mesa

OCPD – Orange County Probation Dept.
1001 South Grand Ave., Santa Ana

OCLL – Orange County Law Library
1170 W. Civic Center Drive, Santa Ana

OCST – Orange County Sheriff's
Department Training Center
1900 W. Katella Ave., Orange

OCTA – Orange County
Transportation Authority
55 S. Main St., Orange

RIVE-GOLF – Riverview Golf Course
1800 W. 22nd, Santa Ana

SAC – Santa Ana College
1530 W. 17th Street, Santa Ana, (714) 564-6000

SCC – Santiago Canyon College
8045 E. Chapman Avenue, Orange, (714) 628-4900

VHS – Valley High School
1801 S. Greenville, Santa Ana

WMC – Western Medical Center
1001 N. Tustin, Santa Ana

The Santa Ana College campus map is printed on page 104



SPRING 2008 WEEKEND CLASSES

The following is a listing of Friday evening, Saturday and Sunday classes offered at Santa Ana College. Refer to the full class listing (beginning on page 27 in this publication) for more complete information.

SANTA ANA COLLEGE

WEEKEND CLASSES

COURSE	TKT #	TIME	DAYS	CAMPUS	DATES
ACCT 101 FINAN ACT	0110102	8:00-12:15pm	S	SAC	2/11-6/08/08
ACCT 102 MANAG ACT	0110210	8:00-12:15pm	S	SAC	2/11-6/08/08
ANTH 100 CULTL ANTH	0210011	6:00-9:10pm	F	SAC	4/18-6/07/08
And		9:00-12:10pm	S	SAC	4/18-6/07/08
ART 009 ART LAB	0600902	12:30-3:40pm	S	SAC	2/11-6/08/08
ART 030 BASIC DRW	0603009	9:00-12:10pm	S	SAC	2/11-6/08/08
ART 051 CERAMICS	0605102	9:00-12:10pm	S	SAC	2/11-6/08/08
ART 100 ART CONCP	0610004	6:00-10:05pm	F	SAC	4/18-5/24/08
And		12:30-4:35pm	S	SAC	4/18-5/24/08
ART 130 INTR/DRAW	0613007	9:00-12:10pm	S	SAC	2/11-6/08/08
And		12:40-3:50pm	S	SAC	2/11-6/08/08
ART 137A AIRBRUSH	0613701	9:00-12:10pm	S	SAC	2/11-6/08/08
ART 137B INT AIRBH	0613702	9:00-12:10pm	S	SAC	2/11-6/08/08
ART 151 CERAMICS	0615102	9:00-12:10pm	S	SAC	2/11-6/08/08
And		12:30-3:40pm	S	SAC	2/11-6/08/08
ART 182 JEWELRY	0618201	9:00-12:10pm	S	SAC	2/11-6/08/08
And		1:00-4:10pm	S	SAC	2/11-6/08/08
ART 195 DIGITAL ART	0619504	6:00-10:15pm	F	SAC	2/11-6/08/08
ART 230 INT DRAW	0623008	9:00-12:10pm	S	SAC	2/11-6/08/08
And		12:40-3:50pm	S	SAC	2/11-6/08/08
ART 233 ADV DRAWNG	0623309	9:00-12:10pm	S	SAC	2/11-6/08/08
And		12:40-3:50pm	S	SAC	2/11-6/08/08
ART 282 JEWELRY 2	0628201	9:00-12:10pm	S	SAC	2/11-6/08/08
And		1:00-4:10pm	S	SAC	2/11-6/08/08
ART 283 JEWELRY 3	0628302	9:00-12:10pm	S	SAC	2/11-6/08/08
And		1:00-4:10pm	S	SAC	2/11-6/08/08
AUTO 002 ESSNTIALS	0800203	6:00-9:10pm	F	SAC	2/11-6/08/08
AUTO 085 SMOG CHECK	0808501	5:30-10:50pm	F	SAC	2/11-6/08/08
BANK 010 TELLR TRA	0901001	9:00-1:50pm	S	SAC	2/16-3/29/08
BANK 010 TELLR TRA	0901002	9:00-2:50pm	S	SAC	4/19-5/24/08
BIOL 109 FUND/BIOL	1010912	9:00-12:10pm	S	SAC	2/11-6/08/08
BIOL 109L FUND LAB	1010975	12:30-3:40pm	S	SAC	2/11-6/08/08
BIOL 109L FUND LAB	1010972	3:30-6:40pm	F	SAC	2/11-6/08/08
BIOL 128 CAL COAST	1012801	Hrs Arr			2/11-4/11/08
BIOL 179 PLANT/ORG	1017901	8:00-12:00pm	S	SAC	2/11-6/08/08
BIOL 239 HUMN ANAT	1023909	8:30-11:40	S	SAC	2/11-6/08/08
And		12:30-3:40pm	S	SAC	2/11-6/08/08
BUS 100 FUNDAMENT	1110009	1:00-3:10pm	S	SAC	2/11-6/08/08
BUS 105 LEGAL ENV	1110503	9:00-12:10pm	S	SAC	2/11-6/08/08
BUS 222 BUS WRITI	1122202	9:00-12:10pm	S	SAC	2/11-6/08/08
BA 036 DATA ENTR	1203601	6:15-9:35pm	F	SAC	2/11-4/04/08
BA 047 LEGAL OFF	1204703	8:00-5:10pm	S	SAC	2/11-3/29/08
BA 056 BUS INTERP	1205602	9:00-12:10pm	S	SAC	2/11-6/08/08
BA 058 LEGAL INTE	1205801	1:00-3:55pm	S	SAC	2/11-6/08/08
BA 110 COMP KEYB	1211008	9:00-1:10pm	S	SAC	2/11-6/08/08
BA 115 COMP KEYB	1211508	9:00-1:10pm	S	SAC	2/11-6/08/08
BA 125 MICROSOFT	1212501	9:00-12:05pm	S	SAC	4/19-6/07/08
BA 147 INT WINDOW	1214702	6:30-9:40pm	F	SAC	2/15-4/04/08
BA 148 ADV WINDOS	1214801	6:30-9:40pm	F	SAC	4/18-6/06/08
BA 188 MICRO XCEL	1218801	9:00-12:10pm	S	SAC	2/16-4/05/08
BA 188 MICRO XCEL	1218805	6:30-9:35pm	F	SAC	4/18-6/06/08
BA 189 EXCEL PROJ	1218901	9:00-12:10pm	S	SAC	4/19-6/07/08
CHEM 209 INTRODUCT	1420907	9:00-12:10pm	S	SAC	2/11-6/08/08
And		12:30-3:40pm	S	SAC	2/11-6/08/08
CNSL 116 PLAN/EXPL	2011627	9:00-12:10pm	S	SAC	2/11-6/08/08
CJ 095 DRUG USE	2209501	8:00-4:50pm	S	SAC	2/23-3/15/08
CJ 098 TERRORISM	2209802	8:00-4:50pm	S	SAC	3/22-4/19/08
CJ 098 ST GANGS	2209801	8:00-4:50pm	S	SAC	4/26-5/17/08

COURSE	TKT #	TIME	DAYS	CAMPUS	DATES
CJ 101 INTR/CJ	2210105	9:00-12:10pm	S	SAC	2/11-6/08/08
DNCE 020 COND/DNCE	2402002	9:00-9:55	S	SAC	2/11-6/08/08
DNCE 113A FLAMENC 1	2411303	10:00-11:55	Su	SAC	2/11-6/08/08
DNCE 113B FLAMENC 2	2411323	11:00-12:55pm	Su	SAC	2/11-6/08/08
DNCE 118 CARIB/LATN	2411801	5:30-7:35pm	F	CDC	4/11-6/08/08
DNCE 119A JAZZ DANC	2411902	10:00-11:55	S	SAC	2/11-6/08/08
DNCE 119B JAZZ DANC	2411922	10:00-11:55	S	SAC	2/11-6/08/08
DNCE 298 SPEC STDY	2429804	11:00-12:55pm	Su	SAC	2/11-6/08/08
ERTH 110 INTR/ERTH	2711004	9:00-12:10pm	S	SAC	2/11-6/08/08
ECON 120 MACRO	2812013	6:00-9:10pm	F	SAC	2/15-4/05/08
And		9:00-12:10pm	S	SAC	2/15-4/05/08
ECON 121 MICRO	2812106	6:00-9:10pm	F	SAC	4/18-6/07/08
And		9:00-12:10pm	S	SAC	4/18-6/07/08
ENGR 011 BASIC BLUE	3201102	4:45-6:50pm	F	SAC	2/11-6/08/08
ENGR 122 ENGR DRAW	3212203	8:00-1:05pm	S	SAC	2/11-6/08/08
And		2 Hrs Arr		SAC	2/11-6/08/08
ENGR 183 AUTOCAD 1	3218307	1:00-2:55pm	S	SAC	2/11-6/08/08
And		2 Hrs Arr		SAC	2/11-6/08/08
ENGR 184 AUTOCAD 2	3218408	8:00-12:10pm	S	SAC	2/11-6/08/08
And		2 Hrs Arr		SAC	2/11-6/08/08
ENGR 185 AUTOCAD 3	3218503	8:00-12:10pm	S	SAC	2/11-6/08/08
And		2 Hrs Arr		SAC	2/11-6/08/08
ENGR 228 DESC GEOM	3222801	8:00-1:05pm	S	SAC	2/11-6/08/08
And		2 Hrs Arr		SAC	2/11-6/08/08
ENGL N50 WRITTEN	3305004	9:00-12:10pm	S	SAC	2/11-6/08/08
ENGL N50 WRITTEN	3305005	6:00-9:10pm	F	SAC	2/11-6/08/08
ENGL N60 BAS/WRTG	3306023	6:00-10:15pm	F	SAC	2/11-6/08/08
ENGL 061 INTR/COMP	3306126	6:00-10:15pm	F	SAC	2/11-6/08/08
ENGL 101 FRSH COMP	3310111	9:00-1:15pm	S	SAC	2/11-6/08/08
ENGL 101 FRSH COMP	3310141	6:00-10:15pm	F	SAC	2/11-6/08/08
ESAC 160 TENNIS	3516001	11:00-1:05pm	Su	TENN	2/11-6/08/08
ESAC 160 TENNIS	3516005	9:00-11:05	S	TENN	2/11-6/08/08
ESAC 260 SOCCER	3526001	10:00-12:05pm	S	SOCC	2/11-6/08/08
ESAF 155 AEROBICS	3555501	8:00-10:05	S	SAC	2/11-6/08/08
ESQA 201 SWIMMING	3580104	9:00-11:05	S	POOL	2/11-6/08/08
ESAQ 206 LAP SWIM	3580602	9:00-11:00	S	POOL	2/11-6/08/08
ESFI 170 YOGA	3597003	8:00-10:05	S	SAC	2/11-6/08/08
ESIA 235 ADV BASEBL	3643501	3:00-6:10pm	S	BSBL	2/11-6/08/08
FDM 005 FASHN LAB	3900503	9:00-1:15pm	S	SAC	2/11-6/08/08
FDM 053 INTR/SEWNG	3905301	9:00-11:05	S	SAC	2/11-6/08/08
FDM 105B INTEM SEW	3910501	9:00-1:00pm	S	SAC	2/11-6/08/08
FDM 215 COMPUTER	3921501	9:00-1:15pm	S	SAC	4/19-6/07/08
GEOG 100 WRLD GEOG	4510009	6:00-9:10pm	F	SAC	4/18-6/07/08
And		9:00-12:10pm	S	SAC	4/18-6/07/08
GEOL 173 DEATH VAL	4617301	Hrs Arr		SAC	5/01-5/15/08
HIST 120 U.S./1865	4812007	6:00-9:10pm	F	SAC	4/18-6/07/08
And		9:00-12:10pm	S	SAC	4/18-6/07/08
HIST 121 FROM 1865	4812108	6:00-9:10pm	F	SAC	4/18-6/07/08
And		9:00-12:10pm	S	SAC	4/18-6/07/08
MGMT 122 BUS COMM	6012202	9:00-12:10pm	S	SAC	2/11-6/08/08
MNFG 011 BLUEPRINT	6251102	4:45-6:50pm	F	SAC	2/11-6/08/08
MNFG 053 TECHNICAL	6255301	7:00-10:10pm	F	SAC	2/11-6/08/08
MNFG 071 CNC WRITNG	6257101	9:00-1:15pm	S	SAC	2/11-6/08/08
MNFG N96 TOOL LAB	6259607	9:00-1:15pm	S	SAC	2/11-6/08/08
MATH N48 PRE ALGEB	6304860	8:00-12:15pm	S	SAC	2/11-6/08/08
MATH 053 TECH MATH	6305301	7:00-10:10pm	F	SAC	2/11-6/08/08
MATH 060 ELE ALGEB	6306060	8:00-12:15pm	S	SAC	2/11-6/08/08
MATH 080 INT ALGEB	6308060	8:00-1:20pm	S	SAC	2/11-6/08/08

Hard work pays off on the weekend!

Friday evening – Sunday evening classes

Earn your Liberal Arts or Business Administration AA (meets transfer requirements for CSUF Business Administration)

Why spend more?

Weekend College at SAC is Your Best Investment.

Annual Fees*

(* based on a 12-unit load at SAC excluding books, parking, room, board, & other fees)

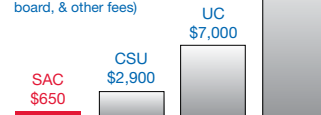

Incl./Private \$18-28,000

COURSE	TKT #	TIME	DAYS	CAMPUS	DATES
MATH 105 MATH/LIB	6310560	8:00-12:15pm	S	SAC	2/11-6/08/08
MATH 140 COLL ALGB	6314060	8:00-12:15pm	S	SAC	2/11-6/08/08
MATH 150 CALCULUS	6315060	8:00-1:20pm	S	SAC	2/11-6/08/08
MATH 219 STATISTICS	6321960	8:00-1:20pm	S	SAC	2/11-6/08/08
MUS 061 PIANO 1	6506107	10:00-12:05pm	S	SAC	2/11-6/08/08
MUS 161 PIANO 1	6516106	10:00-12:05pm	S	SAC	2/11-6/08/08
MUS 165 FLK GUITR	6516502	10:00-12:05pm	S	SAC	2/11-6/08/08
MUS 185 CLS GUITR	6518503	10:00-12:05pm	S	SAC	2/11-6/08/08
MUS 189 GUITAR ENS	6518901	12:15-2:25pm	S	SAC	2/11-6/08/08
And	1 Hr Arr	SAC	2/11-6/08/08
MUS 241 CHMBR MUS	6524103	12:15-2:25pm	S	SAC	2/11-6/08/08
And	1 Hr Arr	SAC	2/11-6/08/08
N-RN 102L NURS WOMN	6810261	220 Hrs Arr	S	SJH	2/11-6/14/08
N-RN 102L NURS WOMN	6810262	220 Hrs Arr	S	GGH	2/11-6/14/08
N-RN 102L NURS WOMN	6810263	220 Hrs Arr	S	WMC	2/11-6/21/08
N-RN 201L CRITCL I	6820152	240 Hrs Arr	S	COH	2/11-6/08/08
N-RN 202L CRITCL II	6820261	256 Hrs Arr	S	UCI	2/11-6/08/08
N-RN 202L CRITCL II	6820262	256 Hrs Arr	S	WMC	2/11-6/08/08
N-RN 202L CRITCL II	6820263	256 Hrs Arr	S	SJH	2/11-6/08/08
PARA 100 INTRO PARA	5710003	8:00-5:10pm	S	SAC	2/23-3/29/08
PARA 130 LEGAL TRAN	5713001	8:00-5:10pm	S	SAC	4/19-5/24/08
PARA 246 LEGAL RESR	5724602	9:00-3:10pm	S	SAC	2/23-6/07/08
PHAR 048 INTR/PHAR	7104803	Hrs Arr	S	SAC	2/09-6/08/08
And	8:00-10:05	S	SAC	2/09-6/08/08
PHAR 054 PHAR CALC	7105403	Hrs Arr	S	SAC	2/09-6/08/08
And	10:15-12:20pm	S	SAC	2/09-6/08/08
PHIL 106 INTR/PHIL	7210613	6:00-9:10pm	F	SAC	4/18-6/07/08
And	9:00-12:10pm	S	SAC	4/18-6/07/08
PHOT 180 BEG PHOTO	7318004	9:00-2:20pm	S	SAC	2/11-6/08/08
PHOT 180 BEG PHOTO	7318005	5:00-10:20pm	F	SAC	2/11-6/08/08
PHOT 190 DIGITAL	7319001	9:00-2:20pm	S	SAC	2/11-6/08/08
PHOT 191 DIGITAL	7319101	9:00-2:20pm	S	SAC	2/11-6/08/08
PHOT 194 COLOR DIG	7319401	9:00-2:20pm	S	SAC	2/11-6/08/08
POLT 101 INTR/GOVN	7610128	6:00-9:10pm	F	SAC	4/18-6/07/08
And	9:00-12:10pm	S	SAC	4/18-6/07/08
PSYC 100 INTR/PSYC	7710019	9:00-12:10pm	S	SAC	2/11-6/08/08
SOCS 219 STATISTICS	8321960	8:00-1:20pm	S	SAC	2/11-6/08/08
SOC 100 INTR/SOC	8410003	6:00-9:10pm	F	SAC	2/15-4/05/08
And	9:00-12:10pm	S	SAC	2/15-4/05/08
SPCH N52A BEG PRON	8705202	9:00-12:10pm	F	SAC	2/15-4/05/08
SPCH N52B INTR PRON	8705201	9:00-1:15pm	S	SAC	2/11-6/08/08
SPCH 101 INTR/COMM	8710140	9:00-12:10pm	S	SAC	2/11-6/08/08
SPCH 101 INTR/COMM	8710133	6:15-9:25pm	F	SAC	2/11-6/08/08
SPCH 102 PBLC SPKG	8710205	6:00-10:15pm	F	SAC	2/22-3/29/08
And	9:00-1:15pm	S	SAC	2/22-3/29/08
THEA 166A PROGRAMMG	9116601	9:00-1:05pm	S	SAC	4/19-4/26/08
And	16 Hrs Arr	SAC	4/19-4/26/08
THEA 166B ADV PROGR	9116602	9:00-1:05pm	S	SAC	4/19-4/26/08
And	16 Hrs Arr	SAC	4/19-4/26/08
THEA 198 READER'S	9119801	1:30-6:50pm	S	SAC	2/11-6/08/08
THEA 250 ADV/PROD	9125003	7:00-9:50pm	F	SAC	4/14-5/30/08
VIET 101 VIETNAM 1	9310102	6:00-8:30pm	F	SAC	2/11-6/08/08
And	9:00-11:30	S	SAC	2/11-6/08/08

THE HONORS PROGRAM AT SANTA ANA COLLEGE



Experience the advantages of small classes (no more than 18 students), individualized attention from professors and peers, and an enriched academic environment. All honors courses are transferable, require a minimum 3.0 GPA, and carry an advisory reading level of 4. Students need not be in the honors program to take an honors class, and classes may be taken at either college to fulfill honors program requirements. For more information on honors classes or the honors program at SAC, contact Kathy Patterson, (714) 564-6528, office D-428, Santa Ana College. You may preregister if you meet the prerequisite requirements.

SPRING 2008 HONORS CLASSES:

- Accounting 102H, Honors Managerial Accounting**
0110231 1:00-3:05pm MW Mitchell SAC A-211
- Anthropology 100H, Honors Introduction To Cultural Anthropology**
Tkt 0210031 1:00-4:35pm MTWTh Wood SAC D-401
- Earth Science 110H, Honors Introduction To Earth Science**
Tkt 2711014 1:30-4:30pm W Coyne SAC R-111
- English 101H, Honors Freshman Composition**
Tkt 3310176 7:30am-9:35 TTh Bassett SAC B-7
- English 103H, Honors Critical Thinking And Writing**
Tkt 3310375 8:00-10:05 TTh Patterson SAC B-5
- English 103H, Honors Critical Thinking And Writing**
Tkt 3310377 1:15-3:20pm MW Munoz SAC D-211
- Geography 100H, Honors World Regional Geography**
Tkt 4510011 8:00-11:35 MTWTh Courter SAC D-202
- History 101H, Honors World Civilizations To The 16th Century**
Tkt 4810131 7:00-10:10pm M Martin SAC D-210
- History 121H, Honors The United States Since 1865**
Tkt 4812131 11:30-12:55pm MW Osborne SAC B-31
- History 124H, Honors Mexican-American History in the U. S.**
Tkt 4812431 11:30-12:55pm MW Guzman SAC D-214
- History 128H, Honors America And The Quest For Global Reform**
Tkt 4812831 7:00-10:10pm W Osborne SAC D-212
- Interdisciplinary Studies 117H, Honors Intro. to Global Studies**
Tkt 5211701 1:00-3:50pm M Wood SAC D-401
- Mathematics 219H, Honors Statistics & Probability**
Tkt 6321975 1:00-3:30pm MW McClure SAC A-213
- Music 101H, Honors Music Appreciation**
Tkt 6510150 11:00-12:25pm TTh Jones SAC N-117
- Music 102H, Honors World Music**
Tkt 6510201 6:00-9:10pm W Brener SAC N-105
- Nutrition & Food 115H, Honors Nutrition**
Tkt 6911504 6:30-9:40pm M Marshall
- Philosophy 110H, Honors Critical Thinking**
Tkt 7211075 5:00-9:45pm MTWTh Fish SAC D-210
- Political Science 101H, Honors Intro. to American Governments**
Tkt 7610175 7:00-10:10pm M Becker SAC D-106
- Psychology 100H, Honors Introduction To Psychology**
Tkt 7710031 7:00-10:10pm T Larson SAC D-212
- Social Science 219H, Honors Statistics And Probability**
Tkt 8321975 1:00-3:30pm MW McClure SAC A-213
- Spanish 102H, Honors Elementary Spanish II**
Tkt 8510275 12:00-2:30pm TTh Guerrero SAC D-206
- Speech Comm. 101H, Honors Intro. to Interpersonal Comm.**
Tkt 8710199 3:00-6:10pm W Fondren SAC C-214
- Television/Video Comm. 105H, Honors Mass Media & Society**
Tkt 9010531 9:30-10:55 MW Bales SAC A-210

SANTA ANA COLLEGE

HONORS CLASSES

UniversityLink

Take part in this unique program!



This outstanding academic program provides all students with the opportunity to attend Santa Ana College with guaranteed admission to UCI.

APPLICATION PROCESS

Applicants must attend a program orientation at Santa Ana College. To sign up for the next orientation meeting, visit the University Transfer Center (S-132), or email U-Link counselor and program coordinator at Zook_Rochelle@sac.edu.



Earn full credit in half the time by enrolling in GR8 Weeks courses. These mini-semester classes run for only eight weeks and are offered in two blocks; at the beginning and middle of the semester. The demand is high and classes are popular so enroll now to save your space. **Don't W8!**

**FOR MORE INFORMATION OR TO
MAKE A COUNSELING APPOINTMENT,
CALL: SANTA ANA COLLEGE - 714/564-6100**

1ST 8-WEEK COURSES FOR SPRING 2008

COURSE	TKT #	TIME	DAYS	CAMPUS	DATES
ACCT 032 COMPENSTN	0103201	4:45-6:50pm	M	SAC	2/11-3/31/08
ACCT 035 QUICKBOOKS	0103505	12:00-1:35pm	W	SAC	2/13-4/02/08
And		2 Hrs Arr		SAC	2/13-4/02/08
ACCT 035 QUICKBOOKS	0103502	7:00-10:25pm	M	SAC	2/11-3/31/08
BANK 010 TELLR TRA	0901001	9:00-1:50pm	S	SAC	2/16-3/29/08
BUS 141 GLOBALIZE	1114101	6:00-10:05pm	T	SAC	2/12-3/04/08
BUS 142 RESEARCH	1114201	6:00-10:05pm	Th	SAC	3/11-4/01/08
BUS 165 INT TRADE	1116501	6:00-10:05pm	T	SAC	3/13-4/03/08
BUS 166 IMPORT/EX	1116601	6:00-10:05pm	Th	SAC	2/14-3/06/08
BA 035 COMP BASI	1203501	11:00-12:30pm	MW	SAC	2/11-4/02/08
And		1 Hr Arr		SAC	2/11-4/02/08
BA 035 COMP BASI	1203503	7:00-10:10pm	T	SAC	2/12-4/01/08
BA 036 DATA ENTR	1203601	6:15-9:35pm	F	SAC	2/15-4/04/08
And		1 Hr Arr		SAC	2/15-4/04/08
BA 047 LEGAL OFF	1204701	8:00-11:10		SAC	2/12-4/03/08
BA 047 LEGAL OFF	1204703	8:00-5:10pm	S	SAC	2/23-3/29/08
BA 147 INT WINDOW	1214703	9:15-10:40	TTh	SAC	2/12-4/03/08
And		1 Hr Arr		SAC	2/12-4/03/08
BA 147 INT WINDOW	1214702	6:30-9:40pm	F	SAC	2/15-4/04/08
And		1 Hr Arr		SAC	2/15-4/04/08
BA 188 MICRO XCEL	1218803	Hrs Arr		SAC	2/11-3/31/08
And		1 Hr Arr		SAC	2/11-3/31/08
BA 188 MICRO XCEL	1218801	9:00-12:10pm	S	SAC	2/16-4/05/08
And		1 Hr Arr		SAC	2/16-4/05/08
BA 190 MICFT PWPT	1219002	9:30-11:00	MW	SAC	2/11-4/02/08
And		1 Hr Arr		SAC	2/11-4/02/08
BA 190 MICFT PWPT	1219004	Hrs Arr		SAC	2/11-4/04/08
And		1 Hr Arr		SAC	2/11-4/04/08
CNSL 100 LIFELONG	2010012	6:00-10:15pm	T	SAC	2/12-4/01/08
CNSL 114 TEACHING	2011401	4:45-6:50pm	Th	SAC	2/14-4/03/08
CJ 095 DRUG USE	2209501	8:00-4:50pm	S	SAC	2/23-3/15/08
CJ 098 TERRORISM	2209802	8:00-4:50pm	S	SAC	3/22-4/19/08
DNCE 109 PILATES CO	2410903	5:30-6:45pm	MW	SAC	2/20-4/02/08
ECON 120 MACRO	2812014	5:30-8:40pm	TTh	SAC	2/12-4/01/08
ECON 120 MACRO	2812013	6:00-9:10pm	F	SAC	2/15-4/05/08
And		9:00-12:10pm	S	SAC	2/15-4/05/08

2ND 8-WEEK COURSES FOR SPRING 2008

COURSE	TKT #	TIME	DAYS	CAMPUS	DATES
ACCT 032 COMPENSTN	0103202	4:45-6:50pm	M	SAC	4/14-6/02/08
ACCT 035 QUICKBOOKS	0103506	12:00-1:35pm	W	SAC	4/16-6/04/08
And		2 Hrs Arr		SAC	4/16-6/04/08
ACCT 035 QUICKBOOKS	0103503	7:00-10:25pm	M	SAC	4/14-6/02/08
ANTH 100 CULTL ANTH	0210011	6:00-9:10pm	F	SAC	4/18-6/07/08
And		9:00-12:10pm	S	SAC	4/18-6/07/08
ART 100 ART CONCP	0610004	6:00-10:05pm	F	SAC	4/18-5/24/08
And		12:30-4:35pm	S	SAC	4/18-5/24/08
ART 196B ADV MODEL	0619601	6:00-10:15pm	T	SAC	4/14-6/02/08
And		5 Hrs Arr		SAC	4/14-6/02/08
ART 296 CMPR GRPH	0629604	6:00-10:15pm	T	SAC	4/14-6/02/08
And		5 Hrs Arr		SAC	4/14-6/02/08
BANK 010 TELLR TRA	0901002	9:00-2:50pm	S	SAC	4/19-5/24/08
BUS 143 PKG/PRICNG	1114301	6:00-10:05pm	T	SAC	4/15-5/06/08
BUS 145 CHANNELS	1114501	6:00-10:05pm	T	SAC	5/13-6/03/08
BUS 150 INTR COMP	1115002	5:30-10:05pm	MW	SAC	4/14-6/04/08
BUS 163 INTL PMT/C	1116301	6:00-10:05pm	Th	SAC	5/15-6/05/08
BUS 164 ALT FINAN	1116401	6:00-10:05pm	Th	SAC	4/17-5/08/08
BA 034 MACH CALC	1203401	2:00-5:05pm	T	SAC	4/15-6/03/08
BA 038 TELEPHONE	1203801	1:00-5:05pm	Th	SAC	4/24-4/29/08
BA 043 MICROSOFT	1204301	5:00-6:55pm	M	SAC	5/12-6/02/08
BA 049 MICROSOFT	1204902	7:00-10:15pm	T	SAC	4/15-6/02/08
BA 125 MICROSOFT	1212501	9:00-12:05pm	S	SAC	4/19-6/07/08
BA 148 ADV WINDOS	1214802	9:15-10:40	TTh	SAC	4/15-6/05/08

COURSE	TKT #	TIME	DAYS	CAMPUS	DATES
ESHE 105 FIRST AID	3610501	9:40-11:05	TTh	SAC	2/11-4/03/08
ESHE 107 CARDIOPUL	3610701	7:30am-9:35	TTh	SAC	2/12-4/03/08
ESHE 107 CARDIOPUL	3610704	6:00-9:40pm	W	SAC	2/11-4/14/08
ESIA 202 BASKBL MEN	3640201	4:50-7:00pm	MTWThF	SAC	2/11-4/04/08
ESIA 212 BASKETBALL	3641201	2:40-4:50pm	MTWThF	SAC	2/11-4/04/08
FDM 216 CMPR PATTN	3921601	5:45-10:00pm	Th	SAC	2/14-4/03/08
GEOL 172 CAL COAST	4617201	Hrs Arr		SAC	3/27-4/17/08
HU-D 113 TUTORING	4911301	3:00-6:15pm	W	SAC	2/27-3/26/08
HU-D 114 TEACHING	4911401	4:45-6:50pm	Th	SAC	2/14-4/03/08
HU-D 221 PERSPECTIV	4922101	11:00-2:10pm	MW	SAC	2/11-4/02/08
MA 020 PATHOGEN	6402002	8:00-4:30pm	F	SAC	3/28-3/28/08
MUS 142 MUSIC MIDI	6514203	1:00-1:55pm	MW	DMC-204	2/11-4/02/08
And		2 Hrs Arr		SAC	2/11-4/02/08
MUS 144 ELECTRONI	6514403	1:00-1:55pm	MW	DMC-204	2/11-4/02/08
And		4 Hrs Arr		SAC	2/11-4/02/08
MUS 146 DIGITAL	6514601	6:00-9:05pm	W	DMC-204	2/13-4/02/08
And		3 Hrs Arr		DMC-204	2/13-4/02/08
PARA 100 INTRO PARA	5710001	8:00-11:10	TTh	SAC	2/12-4/03/08
PARA 100 INTRO PARA	5710003	8:00-5:10pm	S	SAC	2/23-3/29/08
PARA 121 ETHICS	5712102	Hrs Arr		SAC	2/11-3/17/08
PARA 134 PROBATE	5713401	7:00-10:10pm	Th	SAC	2/14-4/03/08
PARA 137 TORT & INS	5713701	6:00-10:10pm	W	SAC	2/13-4/02/08
PARA 143 CIVIL LIT	5714301	6:00-10:10pm	T	SAC	2/12-4/01/08
PHIL 106 INTR/PHIL	7210609	5:30-8:40pm	MW	SAC	2/11-4/02/08
SOC 100 INTR/SOC	8410003	6:00-9:10pm	F	SAC	2/15-4/05/08
And		9:00-12:10pm	S	SAC	2/15-4/05/08
SPCH 102 PBLC SPKG	8710205	6:00-10:15pm	F	SAC	2/22-3/29/08
And		9:00-1:15pm	S	SAC	2/22-3/29/08
SURV 098 CAREERS	8909801	7:00-10:10pm	Th	SCC	2/14-4/03/08
THEA 166A PROGRAMMG	9116601	9:00-1:05pm	S	SAC	4/19-4/26/08
And		16 Hrs Arr		SAC	4/19-4/26/08
THEA 166B ADV PROGR	9116602	9:00-1:05pm	S	SAC	4/19-4/26/08
And		16 Hrs Arr		SAC	4/19-4/26/08
THEA 250 ADV/PROD	9125001	7:00-10:05pm	MTWTh	SAC	2/18-4/04/08
And		7:00-8:50pm	F	SAC	2/18-4/04/08

2ND 8-WEEK COURSES FOR SPRING 2008 (continued)

COURSE	TKT #	TIME	DAYS	CAMPUS	DATES
ESHE 107 CARDIOPUL	3610702	.9:30-11:35	.TTh	.SAC	.4/15-6/05/08
ESIA 124 CONDT MEN	3632405	.9:00-11:30	.MTWThF	.SOCC	.1/02-2/01/08
ESIA 124 CONDT MEN	3632403	.1:00-3:45pm	.MTWThF	.TRCK	.1/02-2/01/08
ESIA 124 CONDT MEN	3632404	.3:00-5:30pm	.MTWThF	.BSBL	.1/02-2/01/08
ESIA 124 CONDT MEN	3632402	.4:15-6:45pm	.MTWThF	.SAC	.1/02-2/01/08
ESIA 128 CONDT WOM	3632802	.1:30-4:00pm	.MTWThF	.SAC	.1/02-2/01/08
ESIA 128 CONDT WOM	3632803	.3:00-6:00pm	.MTWThF	.TRCK	.1/02-2/01/08
ESIA 160 THEORY SB	3636001	.1:00-2:35pm	.MTWThF	.SAC	.1/02-2/01/08
ESOF 169 WRESTLING	3656901	.7:00-10:05pm	.MW	.SAC	.4/14-6/04/08
ESOF 261 SOCCER WMN	3666101	.3:00-6:05pm	.MW	.SOCC	.4/14-6/06/08
ESOF 262 SOCCER MEN	3666201	.5:00-7:05pm	.MWF	.SOCC	.4/14-6/06/08
FDM 215 COMPUTER	3921501	.9:00-1:15pm	.S	.SAC	.4/19-6/07/08
GEOG 100 WRLD GEOG	4510008	.5:30-8:40pm	.MW	.SAC	.4/14-6/04/08
GEOG 100 WRLD GEOG	4510009	.6:00-9:10pm	.F	.SAC	.4/18-6/07/08
And		.9:00-12:10pm	.S	.SAC	.4/18-6/07/08
GEOL 173 DEATH VAL	4617301	.Hrs Arr		.SAC	.5/01-5/15/08
HIST 120 U.S./1865	4812007	.6:00-9:10pm	.F	.SAC	.4/18-6/07/08
And		.9:00-12:10pm	.S	.SAC	.4/18-6/07/08
HIST 121 FROM 1865	4812108	.6:00-9:10pm	.F	.SAC	.4/18-6/07/08
And		.9:00-12:10pm	.S	.SAC	.4/18-6/07/08
HU-D 114 TEACHING	4911402	.4:00-6:05pm	.Th	.SAC	.4/17-6/05/08
MUS 144 ELECTRONI	6514402	.1:00-2:25pm	.MW	.DMC-204	.4/14-6/04/08
And		.3 Hrs Arr		.DMC-204	.4/14-6/04/08

COURSE	TKT #	TIME	DAYS	CAMPUS	DATES
MUS 144 ELECTRONI	6514401	.6:00-9:05pm	.W	.DMC-204	.4/16-6/04/08
And		.4 Hrs Arr			.4/16-6/04/08
MUS 147 DIGITAL II	6514701	.6:00-9:05pm	.W	.DMC-204	.4/16-6/04/08
And		.3 Hrs Arr			.4/16-6/04/08
MUS 148 DIGITAL	6514801	.1:00-2:25pm	.MW	.DMC-204	.4/14-6/04/08
And		.3 Hrs Arr			.4/14-6/04/08
PARA 130 LEGAL TRAN	5713001	.8:00-5:10pm	.S	.SAC	.4/19-5/24/08
PARA 135 BANKRUPTCY	5713501	.6:00-10:10pm	.Th	.SAC	.4/16-6/04/08
PARA 136 REAL PROPT	5713602	.8:00-11:10	.TTh	.SAC	.4/15-6/05/08
PARA 144 DISC TECH	5714401	.6:00-10:10pm	.T	.SAC	.4/15-6/03/08
PHIL 106 INTR/PHIL	7210613	.6:00-9:10pm	.F	.SAC	.4/18-6/07/08
And		.9:00-12:10pm	.S	.SAC	.4/18-6/07/08
POLT 101 INTR/GOVN	7610118	.1:00-4:10pm	.TTh	.SAC	.4/15-6/05/08
POLT 101 INTR/GOVN	7610128	.6:00-9:10pm	.F	.SAC	.4/18-6/07/08
And		.9:00-12:10pm	.S	.SAC	.4/18-6/07/08
READ N90A INDV READ	8009012	.1:00-4:10pm	.TTh	.SAC	.4/15-6/05/08
READ N90B INDV READ	8009032	.1:00-4:10pm	.TTh	.SAC	.4/15-6/05/08
READ 100A ADV READ	8010010	.1:00-4:10pm	.TTh	.SAC	.4/15-6/05/08
READ 100B ADV/READ	8010030	.1:00-4:10pm	.TTh	.SAC	.4/15-6/05/08
STDY 091 STDY TECH	8809103	.12:30-2:20pm	.Th	.SAC	.4/24-6/05/08
TELV 182 ADV MODEL	9018201	.6:00-10:15pm	.T	.SAC	.4/14-6/02/08
And		.5 Hrs Arr		.SAC	.4/14-6/02/08
THEA 135 TECH PROD	9113503	.80 Hrs Arr		.SAC	.4/14-6/08/08

ONLINE COURSES FOR SPRING 2008

Participation/Attendance, and Exams

Students enrolling in the following courses will have the opportunity to complete most of their course work outside of the classroom, although some classes combine mandatory on campus meetings with online instruction. On campus meeting dates are listed for most classes. Students may access course materials via the Internet either at home or using an on campus computer. Students are required to log onto the class website and email the instructor during the first week of the class or they may be dropped from the class roster. A Santa Ana College instructor will be available on campus, by phone, or email to answer questions or discuss course material during the course.

Course Information

Information about online classes such as course orientation or meeting dates, time and place, Frequently Asked Questions, course requirements, textbook and instructor contact information can be found at <http://www.sac.edu/disted>. Students on wait lists must email the instructor the first week of class to be considered for enrollment.

COURSE / TITLE / UNITS TICKET # / INSTRUCTOR / EMAIL HOW TO GET STARTED

Accounting 035 **Quickbooks** **1.5 units**
103505 S. Shain Shain_Sheila@sac.edu
2/13/2008–4/2/2008. Online instruction plus mandatory on-campus meeting every Wednesday, 12 noon–1:35pm, SAC A-222.

Accounting 035 **Quickbooks** **1.5 Units**
103506 S. Shain Shain_Sheila@sac.edu
4/16/2008–6/4/2008. Online instruction plus mandatory on-campus meeting every Wednesday, 12 noon–1:35pm, SAC A-222.

Accounting 102 **Managerial Accounting**
(CAN BUS 4) (CAN BUS SEQ A = ACCT 101 + 102) **4 units**
110204 J. Trone Trone_Jinhee@sac.edu
Online instruction plus mandatory on-campus meetings every Wednesday, 9:30–11:35am, SAC A-209. Go to www.sac.edu/disted for more information. Email instructor first week of class.

Accounting 104 **Federal and California Taxes** **4 units**
0110402 or 0110404 J. Trone Trone_jinhee@sac.edu
Orientation Thurs, Feb 14, 12pm and Wed, Feb 13, 6:30, SAC A-108. Go to www.sac.edu/disted for more information. Email instructor first week of class.

Anthropology 100 **Cultural Anthropology** **3 units**
210015 L. Light Light_Linda@sac.edu
Online instruction plus mandatory on-campus meetings. Students must attend all of the following on campus meetings, Monday, Feb 11, Mar 3, Mar 24, Apr 28, May 19, 4–5:50 p.m., SAC D-103. Email instructor first week of class.

Art 100 **Introduction to Art Concepts** **3 units**
610006 M. Redfield Redfield_Michael@sac.edu
Go to www.sac.edu/disted for more information. Email instructor first week of class.

Access Requirements

You must email your instructor the first week of class. Online courses require students to have access to a computer with an individual email account and Internet access. Internet access is also available to students in the Santa Ana College Academic Computing Center, located in the Cesar Chavez Building (A-106), the Business Division Computer Labs, and the SAC Nealley Library. Santa Ana College uses Blackboard for most of its online courses. Students enrolled in most online classes will log on to: <http://rsccd.blackboard.com>. MAC users enrolling in Math classes should check computer compatibility with online course program, MyMathLab, before enrolling.

Hardware Requirements

Windows 98, 2000, XP / MAC OS 9.2 or higher
64 MB of RAM, 20 MB of free disk space
56k modem or higher
JavaScript and Cookies must be enabled.



Online courses are identified in the class listing by this symbol.

COURSE / TITLE / UNITS TICKET # / INSTRUCTOR / EMAIL HOW TO GET STARTED

Art 100 **Introduction to Art Concepts** **3 units**
610099 L. Wildermuth Wildermuth_Lisa@sac.edu
Go to www.sac.edu/disted for more information. Email instructor first week of class.

Art 101 **Survey of Western Art History** **3 units**
610102 L. Wildermuth Wildermuth_Lisa@sac.edu
Go to www.sac.edu/disted for more information. Email instructor first week of class.

Biology 109 **Fundamentals of Biology** **3 units**
1010911 or 1010915 M. Rourke Rourke_Michael@sac.edu
Go to www.sac.edu/disted for more information. Email instructor first week of class.

Biology 109 **Fundamentals of Biology** **3 units**
1010914 M. Priest Priest_Michelle@sac.edu
Go to www.sac.edu/disted for more information. Email instructor first week of class.



Buy your Textbooks, SAC Gear and Supplies online at:
www.donbookstore.com

Spring 2008 books sold online beginning January 28.
Pay with your Visa or MasterCard. Have books delivered FedEx, or pick them up in our express Web line at the Don Bookstore.

SPRING 2008 ONLINE COURSES *continued...*

COURSE / TITLE / UNITS TICKET # / INSTRUCTOR / EMAIL HOW TO GET STARTED		
Biology 217 1021702 1/7/2008–1/31/2008. Online instruction plus mandatory on-campus meetings. Students must attend all of the following on-campus meetings: Monday, Jan 7, 14, 21 and Thurs., Jan 31 (Final exam), 10:30am-12:30pm, SAC W-101. Students must have Microsoft Word, Powerpoint, and Adobe Acrobat for this course. Go to www.sac.edu/disted for more information.	Pathophysiology J. Hampton Hampton_Jubal@sac.edu	2 units
Accounting 035 Biology 217 1021701 Online instruction plus mandatory on-campus meetings. Students must attend all of the following on-campus meetings, Wednesdays, Feb 6, 27, Thursdays, Mar 20, Apr 17, May 8, 29 (Final exam), 6-8pm, SAC R-303-1. Go to www.sac.edu/disted for more information.	Quickbooks Pathophysiology J. Hampton Hampton_Jubal@sac.edu	1.5 units 2 units
Biology 239 1023950 Complete online orientation exercises: http://ext.sac.edu/faculty_staff/mansfield_patricia On campus lab every Friday 6:30–9:40 pm, SAC R-201	General Human Anatomy (Includes on campus lab.) P. Mansfield Mansfield_Patricia@sac.edu	4 units
Biology 239 1023951 Complete online orientation exercises: http://ext.sac.edu/faculty_staff/mansfield_patricia TKT #1023951 utilizes cadaver dissection. On campus lab Fridays 3:00–6:10 pm, SAC, R-201	General Human Anatomy (Includes on campus lab.) P. Mansfield Mansfield_Patricia@sac.edu	4 units
Biology 249 1024950 Complete online orientation exercises: http://ext.sac.edu/faculty_staff/mansfield_patricia On campus lab Wednesdays 5:00–8:10 PM, SAC R-201	Human Physiology P. Mansfield Mansfield_Patricia@sac.edu	4 units
Biology 249 1024951 Complete online orientation exercises: http://ext.sac.edu/faculty_staff/mansfield_patricia On campus lab Tuesdays 5:00–8:10 PM, SAC R-201	Human Physiology P. Mansfield Mansfield_Patricia@sac.edu	4 units
Business 100 1110010 Orientation Wed, Feb 13, 5:00–6:30pm, SAC A-108. Go to www.sac.edu/disted for more information. Email instructor first week of class.	Fundamentals of Business M. Grant Grant_Madeline@sac.edu	3 units
Business 130 1113005 Orientation Mon, Feb 11, 7:00pm and Tues, Feb 12, 3:30pm, SAC A104. Go to www.sac.edu/disted for more information. Email instructor first week of class	Personal Finance R. Koenig Koenig_Robert@sac.edu	3 units
Business 130 1113008 1/7/2008–2/6/2008. Orientation Monday, Jan 7, 6pm, SAC A-104. Go to www.sac.edu/disted for more information. Email instructor first week of class	Personal Finance E. Mitchell Mitchell_Earl@sac.edu	3 units
Business 140 1114002 1/7/2008–2/2/2008 Orientation Monday, Jan 7, 6pm, SAC A-104. Go to www.sac.edu/disted for more information. Email instructor first week of class	Principles of Finance E. Mitchell Mitchell_Earl@sac.edu	3 units
Business 150 1115004 Mandatory orientation Tuesday, Feb 12, 5pm and/or Wednesday, Feb 13, 11:30am, SAC A-108. Go to www.sac.edu/disted for more information. Email instructor first week of class.	Introduction to Information Systems and Computer Programs C. Kushida Kushida_Cherylee@sac.edu	4 units
Business 160 1116002 Orientation Tuesday, Feb 12, 5pm, SAC A-104. Go to www.sac.edu/disted for more information. Email instructor first week of class.	Introduction to Security Investments R. Ridgeway Ridgeway_Ron@sac.edu	3 units
Business Applications 054 1205401 Mandatory orientation Wednesday, Feb 13, 6pm and/or Thurs, Feb 14, 2pm, SAC A-108. Go to www.sac.edu/disted for more information. Email instructor first week of class.	International Computer Applications M. Hernandez Hernandez_Maria@sac.edu	3 units
Business Applications 110 1211012 Mandatory orientation Wednesday, Feb 13, 2pm and/or 6pm, SAC A-108. Go to www.sac.edu/disted for more information. Email instructor first week of class.	Keyboarding Skills M. Hernandez Hernandez_Maria@sac.edu	1–2 units
Business Applications 115 1211512 Mandatory orientation Wednesday, Feb 13, 2pm and/or 6pm, SAC A-108. Go to www.sac.edu/disted for more information. Email instructor first week of class.	Speed and Accuracy M. Hernandez Hernandez_Maria@sac.edu	1–2 units

COURSE / TITLE / UNITS TICKET # / INSTRUCTOR / EMAIL HOW TO GET STARTED		
Business Applications 179 1217902 Mandatory orientation Tuesday, Feb 12, 6pm SAC A-104 and/or Thursday, Feb 14, 1:30pm, SAC A-108. Go to www.sac.edu/disted for more information. Email instructor first week of class.	Introduction to Microsoft Office M. Hernandez Hernandez_Maria@sac.edu	3 units
Business Applications 180 1218001 Mandatory orientation Wednesday, Feb 13, 7pm and/or Thursday, Feb 14, 1pm, SAC A-104. Go to www.sac.edu/disted for more information. Email instructor first week of class.	Advanced Microsoft Office M. Nguyen Nguyen_Michael@sac.edu	3 units
Business Applications 183 1218302 Mandatory orientation Wednesday, Feb 13, 7pm and/or Thursday, Feb 14, 1pm, SAC A-104. Go to www.sac.edu/disted for more information. Email instructor first week of class.	Microsoft Word M. Nguyen Nguyen_Michael@sac.edu	3 units
Business Applications 185 1218501 Online instruction plus mandatory on campus meeting Monday, Feb 11, 8:30–10pm, Mar 3, Mar 17, Mar 31, Apr 21, May 5, May 19, June 2, 7–10pm, SAC A-226. Go to www.sac.edu/disted for more information.	Real World Microsoft Office Project C. Lehrer Lehrer_Carol@sac.edu	3 units
Business Applications 188 1218803 2/11/2008–3/31/2008. Orientation Thursday, Feb 14, 1:30pm and/or 5:30pm and/or Thursday, Feb 14, 1:30pm, SAC A-104. Go to www.sac.edu/disted for more information. Email instructor first week of class.	Microsoft Excel M. Nguyen Nguyen_Michael@sac.edu	1.5 units
Business Applications 190 1219004 2/11/2008–4/4/2008. Go to www.sac.edu/disted for more information. Email instructor first week of class.	Microsoft PowerPoint J. Osgood Osgood_Joanne@sac.edu	1.5 units
Business Applications 191 1219101 4/14/2008–6/8/2008. Orientation Wednesday, Apr 16, 5pm, SAC A-108. Go to www.sac.edu/disted for more information. Email instructor first week of class.	PowerPoint Application C. Lehrer Lehrer_Carol@sac.edu	1.5 units
Business Applications 198 1219801 Online instruction plus mandatory on-campus meetings. Students must attend all of the following meetings: Tuesday, Feb 12, Feb 19, Mar 4, Mar 18, Apr 1, Apr 22, May 6, May 20, June 3, 7:00 pm, SAC A-222. Go to www.sac.edu/disted for more information. Email instructor first week of class.	Introduction to Geographic Information Systems D. Crowley Crowley_Debra@sac.edu	3 units
Business Applications 198 1219802 Online instruction plus mandatory on-campus meetings. Students must attend all of the following meetings: Tuesday, Feb 12, Feb 26, Mar 11, Mar 25, Apr 15, Apr 29, May 13, May 27, June 3, 7:00 pm, SAC A-222. Go to www.sac.edu/disted for more information. Email instructor first week of class.	Intermediate Geographic Information Systems D. Crowley Crowley_Debra@sac.edu	3 units
Computer Science 100 1710019 Mandatory orientation Tuesday, Feb 12, 6:30pm and/or Wednesday, Feb 13, 1:00pm, SAC A-108. Go to www.sac.edu/disted for more information. Email instructor first week of class.	Computer and Society C. Kushida Kushida_Cherylee@sac.edu	3 units
Computer Science 103 1710309 3/10/2008–5/9/2008. Orientation Monday, Mar 3, 6:30pm, SAC A-104. Go to www.sac.edu/disted for more information. Email instructor first week of class.	Internet & World Wide Web Essentials D. Crowley Crowley_Debra@sac.edu	1.5 units
Computer Science 167 1716703 Mandatory orientation Tuesday, Feb 12, 5:45pm and/or Wednesday, Feb 13, 12:15pm, SAC A-108. Go to www.sac.edu/disted for more information. Email instructor first week of class.	Microsoft Access C. Kushida Kushida_Cherylee@sac.edu	3 units
Counseling 116 2011651 1/8/2008–1/31/2008. Students must attend one of the following orientations: Jan 2, 3, or 8, 7–9pm, or Jan 8, 12–2pm, SAC L-225. For additional information contact the instructor, sadler_dennis@sac.edu or www.sac.edu/students/counseling/staff/sadler.htm	Career/Life Planning and Personal Exploration D. Sadler Sadler_Dennis@sac.edu	3 units
Counseling 116 2011660 Students must attend one of the following orientations: Feb 5, 12, or 19, 7–9 pm, or Feb 12, or 19, 12–2pm, SAC L-225. For additional information contact the instructor, sadler_dennis@sac.edu or www.sac.edu/students/counseling/staff/sadler.htm	Career/Life Planning and Personal Exploration D. Sadler Sadler_Dennis@sac.edu	3 units
Criminal Justice 101 2210113 or 2210115 MANDATORY meeting either Monday, Feb 11 or Tuesday, Feb 12, 6pm CGST, 15991 Armstrong, Tustin, CA 92782. Email instructor by Fri, Feb 8 or call (714)566-9201.	Introduction to Criminal Justice G. Troxcil Troxcil_George@sac.edu	3 units
Criminal Justice 103 2210303 Mandatory orientation meeting Tuesday, Feb 12, 6:30–7:30pm, SAC F-102. Email instructor first week of class. Go to www.sac.edu/disted for more information.	Concepts of Criminal Law A. Gonis Gonis_Andrew@sac.edu	3 units

Academic Planning Questions?
www.sac.edu/online_counseling

SPRING 2008 ONLINE COURSES *continued...*

**COURSE / TITLE / UNITS
TICKET # / INSTRUCTOR / EMAIL
HOW TO GET STARTED**

Economics 120 **Macroeconomics** **3 units**
2812016 L. Ho Ho_Lac@sac.edu
Online instruction plus mandatory on-campus meetings. Students must attend all of the following on-campus meetings, Thursday, Feb 14, Friday, Apr 4, Friday, May 23, 4:30–5:30 p.m., SAC D-209. Email instructor first week of class.

Economics 121 **Microeconomics** **3 units**
2812111 L. Ho Ho_Lac@sac.edu
Online instruction plus mandatory on-campus meetings. Students must attend all of the following on-campus meetings, Thursday, Feb 14, Friday, Apr 4, Friday, May 23, 5:40–6:40 p.m., SAC D-209. Email instructor first week of class.

Education 204
Personal Proficiency in Educational Technologies for Secondary Teachers **3 units**
2920401 C. Lehrer Lehrer_Carol@sac.edu
Online instruction plus mandatory on-campus meetings, Monday, Feb 11, 8:30 to 10pm, Feb 25, Mar 10, Mar 24, Mar 31, Apr 14, Apr 28, May 12, Jun 2, 7–10pm, SAC A-226.

Engineering 148 **Introduction to Engineering** **2 units**
3214802 G. Johnson Johnson_Glenna@sac.edu
Orientation Wednesday, Feb 13, 7pm, SAC A-225. Go to www.sac.edu/disted for more information. Email instructor first week of class.

Engineering 149, Introduction to Architecture/Civil Engineering/ Construction (AEC) **2 units**
3214902 G. Johnson Johnson_Glenna@sac.edu
Orientation Wed, Feb 13, 7pm, SAC A-225. Go to www.sac.edu/disted for more information. Email instructor first week of class.

English 061 **Introduction to Composition** **3 units**
3306106 G. Bennett Bennett_Gary@sac.edu
Online instruction plus mandatory on-campus meetings. Students must attend all of the following on-campus meetings, Tuesday, Feb 12, Mar 18, Apr 29, June 3, 5–6:50 p.m., SAC D-102. Go to www.sac.edu/disted for more information. Email instructor first week of class.

English 061 **Introduction to Composition** **3 units**
3306112 J. Carey Carey_Jennifer@sac.edu
Online instruction plus mandatory on-campus meetings. Students must attend all of the following on-campus meetings, Tuesday, Feb 12, Mar 11, Apr 15, June 3, 5:30–6:50 p.m., SAC D-103. Go to www.sac.edu/disted for more information. Email instructor first week of class.

English 101 **Freshman Composition** **4units**
3310121 G. Bennett Bennett_Gary@sac.edu
Online instruction plus mandatory on-campus meetings. Students must attend all of the following on-campus meetings, Thursday, Feb 14, Mar 20, May 1, June 5, 5–6:50 p.m., SAC D-204. Go to www.sac.edu/disted for more information. Email instructor first week of class.

English 101 **Freshman Composition** **4 units**
3310165 D. Pearce Pearce_Dianne@sac.edu
Online instruction plus mandatory on-campus meetings. Students must attend all of the following on-campus meetings, Thursday, Feb 14, Mar 13, Apr 17, May 15, June 5, 4–5:50 p.m., SAC D-303. Go to www.sac.edu/disted for more information. Email instructor first week of class.

English 101 **Freshman Composition** **4 units**
3310166 N. Kabaji Kabaji_Noha@sac.edu
Online instruction plus mandatory on-campus meetings. Students must attend all of the following on-campus meetings: Tuesday, Feb 12, Mar 11, Apr 22, May 20, June 3, 4–5:50 p.m., SAC D-303. Go to www.sac.edu/disted for more information. Email instructor first week of class.

English 101 **Freshman Composition** **4 units**
3310169 P. Nguyen Nguyen_Pete@sac.edu
Online instruction plus mandatory on-campus meetings. Students must attend all of the following on-campus meetings: Tuesday, Feb. 12, Mar 25, May 13, June 3, 4–5:50 p.m., SAC D-210. Go to www.sac.edu/disted for more information. Email instructor first week of class.

English 102 **Literature and Composition** **4 units**
3310208 C. Ramshaw Ramshaw_Charles@sac.edu
Online instruction plus mandatory on-campus meetings. Students must attend all of the following on-campus meetings, Monday, Feb 11, Mar 17, Apr 21, May 19, 3:45–5:45 p.m., SAC D-102. Go to www.sac.edu/disted for more information. Email instructor first week of class.

English 103 **Critical Thinking and Writing** **4 units**
3310310 M. Beyersdorf Beyersdorf_Matthew@sac.edu
Online instruction plus mandatory on-campus meetings. Students must attend all of the following on-campus meetings, Wednesday, Feb 13, Mar 19, Apr 30, June 4, 5–5:30pm, SAC D-102. Go to www.sac.edu/disted for more information. Email instructor first week of class.

Exercise Science–Fitness 101, Personal Fitness Evaluation **1 unit**
3590102 G. Jones Jones_Geoff@sac.edu
Go to www.sac.edu/disted for more information. Email instructor first week of class.

Exercise Science - Health 101, Healthful Living **3 units**
3610102 D. Breig Breig_David@sac.edu
1/2/2008–2/2/2008. Go to www.sac.edu/disted for more information. Email instructor first week of class.

**COURSE / TITLE / UNITS
TICKET # / INSTRUCTOR / EMAIL
HOW TO GET STARTED**

Exercise Science - Health 101, Healthful Living **3 units**
3610105 D. Breig Breig_David@sac.edu
Go to www.sac.edu/disted for more information. Email instructor first week of class

Exercise Science - Health 101, Healthful Living **3 units**
3610107 D. Breig Breig_David@sac.edu
4/14/2008–6/7/2008. Go to www.sac.edu/disted for more information. Email instructor first week of class

Exercise Science - Health 102, Women's Health **3 units**
3610201 A. Doty Doty_Ann@sac.edu
Go to www.sac.edu/disted for more information. Email instructor first week of class

Exercise Science Professional 125, Sport Psychology **3 units**
3672501 J. Coffman Coffman_Jodi@sac.edu
Combines online and on-campus instruction. Mandatory on campus meetings: Every Monday, Feb 11–June 6, 11:15am–12:40pm, SAC G-107. Go to www.sac.edu/disted for more information. Email instructor first week of class.

Exercise Science Professional 150, Sports in Society **3 units**
3675002 F. Luppani Luppani_Flo@sac.edu
Go to www.sac.edu/disted for more information. Email instructor first week of class.

Exercise Science Professional 198, Education and Sports **3 units**
3679802 A. Siddons Siddons_AI@sac.edu
Go to www.sac.edu/disted for more information. Email instructor first week of class.

Fire Technology 101 **Fire Protection Organization** **3 units**
4210144 D. Stefano Stefano_Daniel@sac.edu
Go to www.sac.edu/disted for more information. Email instructor first week of class.

Fire Technology 104 **Fire Prevention Technology** **3 units**
4210444 S. Freeman Freeman_Suzanne@sac.edu
Go to www.sac.edu/disted for more information. Email instructor first week of class.

Fire Technology 105 **Building Construction for Fire Protection** **3 units**
4210544 or 4210545 D. Wiskus Wiskus_Dennis@sac.edu
Go to www.sac.edu/disted for more information. Email instructor first week of class.

Fire Technology 106 **Fire Protection Equipment and Systems** **3 units**
4210644 D. Wiskus Wiskus_Dennis@sac.edu
Go to www.sac.edu/disted for more information. Email instructor first week of class.

Geography 100 **World Regional Geography** **3 units**
4510010 or 4510013 J. Titus Titus_Jodi@sac.edu
Go to www.sac.edu/disted for more information. Email instructor first week of class.

History 120 **United States History to 1865** **3 units**
4812013 J. Heeren Heeren_Jeffrey@sac.edu
Online instruction plus mandatory on-campus meetings. Students must attend all of the following on-campus meetings, Tuesday, Feb 12, Mar 4, Apr 15, May 6, June 3, 5–6:30 p.m., SAC D-305. Go to www.sac.edu/disted for more information. Email instructor first week of class.

History 121 **United States History Since 1865** **3 units**
4812114 J. Heeren Heeren_Jeffrey@sac.edu
Online instruction plus mandatory on-campus meetings. Students must attend all of the following on-campus meetings, Thursday, Feb 14, Mar 6, Apr 17, May 8, June 5, 4–6:50 p.m., SAC D-102. Go to www.sac.edu/disted for more information. Email instructor first week of class.

Human Development 112 **Health, Safety and Nutrition for Children** **3 units**
4911202 S. Valdez Valdez_Susanne@sac.edu
Online instruction plus mandatory on-campus meetings. Students must attend all of the following on-campus meetings: Saturday, Feb 9, Mar 29, May 3, May 31, and June 7, 9:30am–12:30pm, SAC B-33. Go to www.sac.edu/disted for more information. Email instructor first week of class.

Library & Information Studies 103, Information Retrieval on the Internet **1 unit**
5840301 S. Wood Wood_Suzanne@sac.edu
4/14/2008–5/31/2008. Go to www.sac.edu/disted for more information. Email instructor first week of class.

ONLINE



**COUNSELING 116
Career/Life Planning &
Personal Exploration**

This course meets AA and CSU Gen Ed requirements. Students must attend one of the following orientations:
February 5, 12 or 19, 7-9pm or
February 12 or 19, 12-2pm, SAC L-225.
For additional information contact the instructor at:
Sadler_Dennis@sac.edu or (714) 564-6108

SPRING 2008 ONLINE COURSES *continued...*

COURSE / TITLE / UNITS TICKET # / INSTRUCTOR / EMAIL HOW TO GET STARTED		
Mathematics 060 6306070	Elementary Algebra M. Everett Everett_Mike@sac.edu	4 units Online instruction plus mandatory on-campus meetings. Mandatory class meetings Friday, Feb 8, Mar 14, Apr 18, May 16, Jun 6, 6–8pm, SAC H-107. Go to www.sac.edu/disted for more information. Email instructor first week of class.
Mathematics 080 6308070	Intermediate Algebra C. Solheid Solheid_Christa@sac.edu	4 units Online instruction plus mandatory on-campus meetings: Mandatory class meetings Friday, Feb 8, Mar 14, Apr 18, May 16, Jun 6, 6–8pm, SAC L-207. Go to www.sac.edu/disted for more information. Email instructor first week of class.
Mathematics 080 6308071	Intermediate Algebra C. Solheid Solheid_Christa@sac.edu	4 units Online instruction plus mandatory class meetings Saturday, Feb 9, Mar 15, Apr 19, May 17, and June 7, 9-11:30am, SAC L-203. Go to www.sac.edu/disted for more information. Email instructor first week of class.
Mathematics 105 6310570	Mathematics for Liberal Arts Students (CAN MATH 2) M. Everett Everett_Mike@sac.edu	3 units Online instruction plus mandatory class meetings Friday, Feb 8, Mar 14, May 16, June 6, 4-6pm, SAC H-107. Go to www.sac.edu/disted for more information. Email instructor first week of class.
Mathematics 140 6314070	College Algebra (CAN MATH 4) C. Sorcabal Sorcabal_Charles@sac.edu	4 units Online instruction plus mandatory class meetings Friday, Feb 8, Mar 14, Apr 18, May 16, Jun 6, 6–8pm, SAC H-105. Go to www.sac.edu/disted for more information. Email instructor first week of class.
Music 101 6510199	Music Appreciation E. Jones Jones_Elliott@sac.edu	3 units Online instruction plus mandatory on-campus meetings: Feb 22, Feb 29, Mar 14, Apr 4, and May 2, May 23, 6:30-9:30pm, SAC-N-117. Go to www.sac.edu/disted for more information. Email instructor first week of class.
Music 211 6521199	Music History and Literature E. Jones Jones_Elliott@sac.edu	3 units Online instruction plus mandatory on-campus meetings: Mandatory on-campus meetings Feb 22, Feb 29, Mar 14, Apr 4, and May 2, May 23, 6:30-9:30pm, SAC N-117. Attendance at all campus meetings is mandatory. Go to www.sac.edu/disted for more information.
Nursing, Registered 103 6810302	Pharmacological Concepts of Nursing M. Paunovic Paunovic_Mila@sac.edu	2 units Online instruction plus mandatory on-campus meetings. MANDATORY orientation Wednesday Feb 13, 3-5:05pm, SAC R-128. Testing dates to be arranged. Go to www.sac.edu/disted for more information. N-RN 103 to be taken no sooner than within 1 year of entering the Nursing Program.
Nursing, Registered 112 6811201	Nursing Concepts S. Brown Brown_Stephen@sac.edu	1.5 units Online instruction plus mandatory on-site meetings. Mandatory orientation Thursday, Feb 14, 11–12:35, SAC R-113. Further class meeting dates to be arranged. Go to www.sac.edu/disted for more information. N-RN 112 to be taken no sooner than within 1 year of entering the Nursing Program.
Occupational Therapy Assistant 102 7010201	Psychosocial Function and Dysfunction M. Parolise Parolise_Michelle@sac.edu	4 units Online instruction plus mandatory on-campus labs. Email instructor for more information. Go to www.sac.edu/disted for more information.
Paralegal 101 5710101	Law Office Management R. Manzano Manzano_Rick@sac.edu	2 units 1/8/2008–1/31/2008. Orientation Tuesday, Jan 8, 6-7pm, SAC A-108. Go to www.sac.edu/disted for more information. Email instructor first week of class.
Paralegal 105, Cooperative Work Experience Education–Occupational 5710501	R. Manzano Manzano_Rick@sac.edu	1–4 units Orientation Monday, Feb 11, 6:00–6:50pm, SAC A108. Go to www.sac.edu/disted for more information. Email instructor first week of class.
Paralegal 121 5712102	Ethics for the Paralegal R. Manzano Manzano_Rick@sac.edu	1 unit 2/11/2008–3/17/2008. Orientation Monday, Feb 11, 6:00pm, SAC A-108. Go to www.sac.edu/disted for more information.
Paralegal 299, Cooperative Work Experience Education 5710501	R. Manzano Manzano_Rick@sac.edu	1–4 units Orientation Monday, Feb 11, 6:00–6:50pm, SAC A108. Go to www.sac.edu/disted for more information. Email instructor first week of class.

COURSE / TITLE / UNITS TICKET # / INSTRUCTOR / EMAIL HOW TO GET STARTED		
Pharmacy Technology 048 Introduction to Pharmacy Technology 7104803	K. Huynh-Dang Huynh-dang_KC@sac.edu	2 units Online instruction plus mandatory on-campus meetings. Class will meet on campus every other Saturday from February 9 to June 7, 8–10:05 am, SAC H- 201. Go to www.sac.edu/disted for more information. Email instructor first week of class.
Pharmacy Technology 054 Pharmacy Calculations 7105403	K. Huynh-Dang Huynh-dang_KC@sac.edu	2 units Online instruction plus mandatory on-campus meetings. Class will meet on campus every other Saturday from February 9 to June 7, 10:15–12:20, SAC H-201. Go to www.sac.edu/disted for more information. Email instructor first week of class.
Philosophy 110 7211007	Critical Thinking Z. Fish Fish_Zachary@sac.edu	4 units Online instruction plus mandatory on-campus meetings. Students must attend all of the following on-campus meetings, Monday, Feb 11, Mar 10 Mar 31, Apr 28, May 19, 5–6:45 p.m., SAC D-105. Go to www.sac.edu/disted for more information. Email instructor first week of class.
Political Science 101 7610131	Introduction to Government E. Mendez Mendez_Eva@sac.edu	3 units Online instruction plus mandatory on-campus meetings. Students must attend all of the following on-campus meetings, Wednesday, Feb 13, June 4, 5:30–6:30 pm, SAC D-103. Go to www.sac.edu/disted for more information. Email instructor first week of class.
Sociology 100 8410012	Introduction to Sociology D. Dobos Dobos_David@sac.edu	3 units Online instruction plus mandatory on-campus meetings. Students must attend all of the following on-campus meetings, Wednesday, Feb 13, Mar 5, Apr 2, May 7, June 4, 5–6:00 pm, SAC D-401. Go to www.sac.edu/disted for more information. Email instructor first week of class.
Sociology 112 8411207	Relationships, Marriages, and Family Dynamics D. Dobos Dobos_David@sac.edu	3 units 1/8/2008–1/31/2008. Go to www.sac.edu/disted for more information. Email instructor first week of class.
Sociology 112 8411204 or 8411205	Relationships, Marriages, and Family Dynamics D. Dobos Dobos_David@sac.edu	3 units Go to www.sac.edu/disted for more information. Email instructor first week of class.
Spanish 102 8510207	Elementary Spanish 2 M. Guerrero Guerrero_Martha@sac.edu	5 units Online instruction plus mandatory on-campus meetings. Students must attend all of the following on-campus meetings, Friday, Feb 15, Mar 14, Apr 4, May 9, May 30, 9:30–12 noon., SAC D-305. Go to www.sac.edu/disted for more information. Email instructor first week of class.
Special Services N98 8609801	Transition to College G. Siegel Siegel_Gina@sac.edu	1 unit Online instruction plus mandatory meetings on high school campus: Feb.5, Mar 5, Apr 2, May 7, May 28, (time and location TBA). Go to www.sac.edu/disted for more information. Email instructor first week of class.
Speech Communication 101, Interpersonal Communication 8710179	K. Strong Strong_Kevin@sac.edu	3 units Combines online and on campus instruction. Mandatory on-campus meetings Mondays/Wednesdays as follows: Feb. 11, Mar 31, April 2, May 19, May 21 and May 28, 2-3:20pm, SAC C-202. Go to www.sac.edu/disted for more information. Email instructor first week of class.
Speech Communication 103, Intercultural Communication 8710301	K. Strong Strong_Kevin@sac.edu	3 units Online instruction plus on campus instruction. Mandatory on-campus meetings Mondays/Wednesdays, Feb. 11, Mar 31, Apr 2, May 19, May 21, May 28, 3:30-4:50pm, SAC C-202. Go to www.sac.edu/disted for more information. Email instructor first week of class.
Study Skills 109 8810907	College Learning Skills J. Norwood Norwood_Joyce@sac.edu	3 units Students must attend one of the following on-campus orientations: Monday, February 11, 1–2pm and 6–7pm and/or Tuesday, February 12, 1–2pm and 6–7pm, SAC L-225. Go to www.sac.edu/disted for more information. Email instructor first week of class.
Theatre Arts 100 9110099	Introduction to Theatre (CAN DRAM 18) V. Tivenan Tivenan_Valinda@sac.edu	3 units Go to www.sac.edu/disted for more information. Email instructor first week of class.

Online Counseling Now Available!
www.sac.edu/online_counseling

STUDENTS: Web access to student records and registration is on its way!
Go to www.sac.edu – click on online records and update your student profile with your personal email address. **We'll be in touch.**

TELEVISION COURSES FOR SPRING 2008



TV courses are identified in the full class listing by this symbol

Viewing/Attendance and Exams

Students enrolling in the following courses will have the convenience of at-home viewing of television programs for college credit as well as the opportunity to review the week's taped TV lectures in the college libraries. Students are required to come to Santa Ana College to take the designated examinations and/or other sessions as required by the instructor. An instructor will be available at the campus, by telephone or appointment, to discuss concerns or questions which may develop during the course. Textbooks for all telecourses will be available at the Santa Ana College Bookstore.

COURSE / PROGRAM NAME / UNITS TICKET # / TITLE / INSTRUCTOR DESCRIPTION

Anthropology 100, FACES OF CULTURE 0210081 Intro. to Cultural Anthropology	Linda Light, Instructor	3 units
A multicultural and ethnographic approach to the study of ancient and modern cultures. Presents evolution of human culture from earliest beginnings to modern times.		
Geology 101, INTRODUCTION TO GEOLOGY 4610181 Introduction to Geology	Philip Hughes, Instructor	3 units
Includes external influences (waves, streams, glaciers) and internal forces (earthquakes, volcanism) affecting the earth's surface. Concurrent enrollment in Geology 101L recommended.		
History 120, UNFINISHED NATION, PART 1 4812081 The United States to 1865	Gerald Ghelfi, Instructor	3 units
Examines the development of American culture from its earliest European origins to the end of the Civil War.		
History 121, UNFINISHED NATION, PART 2 4812181 The United States Since 1865	Gerald Ghelfi, Instructor	3 units
A critical analysis of America's political, social, cultural, and diplomatic developments since the Civil War.		
Human Development 107, STEPPING STONES 4910781 Child Growth & Development	James Pugh, Instructor	3 units
Study of the psychological and developmental stages of children.		

Broadcast Schedules are determined by the TV stations and are subject to change without notice. Most television courses are broadcast "over-the-air" on some cable channels, schedules to be announced. Viewing information will be mailed before the semester begins. Some telecourse videos are available for purchase in the bookstore or for checkout in the SAC and SCC libraries.

Course Information

Students enrolling in television courses will be mailed information concerning broadcast schedules, textbooks and examination dates during the first two weeks of the semester. It is extremely important that your current address and phone number is on file in the Admissions Office, as all correspondence is through the mail. Please contact the Distance Education Office, (714) 564-6725, if you do not receive your letter of information by February 8, 2008. Visit our website at www.sac.edu/disted.

COURSE / PROGRAM NAME / UNITS TICKET # / TITLE / INSTRUCTOR DESCRIPTION

Interdisciplinary Studies 121, HUMANITIES THROUGH THE ARTS 5212181 Humanities Through the Arts	B. Kehlenbach, Instructor	3 units
An introduction to the humanities through a study of seven major art forms; film, drama, music, literature, painting, sculpture and architecture.		
Nutrition 115, NUTRITION PATHWAYS 6911581 Nutrition Pathways	Cathi Gilmore, Instructor	3 units
Addresses the basic chemical and scientific aspects of nutrition. Examines nutrition and how it impacts people in their everyday life.		
Philosophy 106, (CAN PHIL 2) EXAMINED LIFE 7210681 Introduction to Philosophy	Tim Snead, Instructor	3 units
Survey of historical and contemporary ideas on how to live the good life.		
Philosophy 108, ETHICS IN AMERICA 7210881 Ethics	Tim Snead, Instructor	3 units
Assists in clarifying our thinking about morality/ethics. Course increases awareness of values in personal and contemporary issues.		
Psychology 100, PSYCHOLOGY: INSIDE OUT 7710081 Introduction to Psychology (Can Psy 2)	Ginger Osborne, Instructor	3 units
Scientific approach to the understanding of behavior, principles of development, learning, motivation, emotion, adjustment. One additional hour per week arranged. Automatic concurrent enrollment in Psychology N19.		
Sociology 100, THE WAY WE LIVE 8410081 Introduction to Sociology	Neal Rogers, Instructor	3 units
1/8/2008-1/31/2008. Study of human social behavior with a focus on cultural, institutional, group and individual variations, changes, and stabilities.		
Sociology 100, THE WAY WE LIVE 8410082 Introduction to Sociology	Neal Rogers, Instructor	3 units
Study of human social behavior with a focus on cultural, institutional, group and individual variations, changes, and stabilities.		
Sociology 112, OUR FAMILIES, OURSELVES 8411281 Marriage and the Family	Neal Rogers, Instructor	3 units
An analysis of information and attitudes which contribute to marriage and family.		
Sociology 112, OUR FAMILIES, OURSELVES 8411282 Marriage and the Family	Neal Rogers, Instructor	3 units
1/8/2008-1/31/2008. An analysis of information and attitudes which contribute to marriage and family.		
Spanish 101, DESTINOS, PART I 8510181 Elementary Spanish I, DESTINOS Part I	Leti Lopez-Jaurequi, Instructor	5 units
Practice and integration of pronunciation, grammar, vocabulary, common idioms, listening, speaking, reading and writing techniques for oral and written communication. Introduction of Hispanic culture. Students must attend all the following on campus meetings: Monday, Feb 11, Mar 10, Apr 1, May 5, June 2, 4:30-6:50pm SAC D-304.		
Spanish 102, DESTINOS, PART 2 8510281 Elementary Spanish II, DESTINOS Part II	Martha Guerrero, Instructor	5 units
A college level Spanish class focusing on dictation, vocabulary and grammar, reading, conversation and composition for the expression of ideas. Prerequisite: Spanish 101 or two years of high school Spanish with a grade of C or better. Students must attend all the following on campus meetings: Wednesday, Feb 13, Mar 12, Apr 3, May 7, June 4, 4:30-6:50pm, SAC D-304.		

Santa Ana College

Looking for a paid internship?
Earn while you learn!

Disney College Program

In partnership with Santa Ana College

Attend an on-campus presentation and learn all about this internship available to SAC Students.

Tuesday, May 6th @ 5:30pm-6:30pm
Wednesday, May 7th @ 12pm-1pm & 5pm-6pm
Thursday, May 8th @ 11am-12pm
In the Cesar Chavez Building, Room A-130

Disney interns can:

- Take classes for academic credit at SAC
- Network with Disneyland leaders
- Work for one of the most admired companies in the world
- Attend Cast Member-exclusive events
- Receive theme park admission and select discounts

For more information, contact Jean Gillis at: (714) 564-6763 or visit our website at: www.mickeyscac.org

Discover why the Disney College Program Internship is an opportunity you just can't afford to miss!



BUSINESS SEMINARS FOR COLLEGE CREDIT

General Management • Communication • Computer Skills • Office Management • Self Improvement • Small Business/Entrepreneur

INCREASE YOUR VALUE to your present employer or learn skills that will make you more valuable in the future. Enroll now in these 8- or 16-hour seminars to IMPROVE YOUR JOB SATISFACTION. Join the 35,000 participants who have utilized this program to KEEP COMPETITIVE in today's business world. TAUGHT BY TRAINED PROFESSIONALS who keep up-to-date on the latest in business and industry. To obtain a Business Seminar Class Schedule contact RSCCD's Public Service Institute (714) 241-5823, or visit <http://sacpsi.org>

FRESHMAN EXPERIENCE – Learning Communities at Santa Ana College

Freshman Experience learning communities are an innovative approach to traditional course offerings, created by linking courses through thematic content, skill development, or a combination of these methods.

Teachers in the linked courses of a Learning Community work as a team, coordinating assignments, exams and other class activities in their specified courses. Students, too, become a team, joining together in a “cohort” or group, to take the linked classes. Recent research suggests that students in learning community classes get to know their teachers and each other better, and they are better able to connect and apply information and learning from one course to another. Participation in learning communities contributes to improved transfer rates, student success and reduced attrition.

Freshman Experience learning communities offer a fresh and exciting way of fulfilling requirements for an AA degree and transfer to Cal State or UC systems.

Other Benefits Include:

- A coordinated work load for classes (assignments and exams).
- Classes that are generally transferable in different categories.
- Opportunities to learn across disciplines.
- Developing lasting friendships and learning from peers in an intimate academic atmosphere.
- Gaining refreshing insights into current schools of thought within traditional disciplines.

Important:

Students are required to enroll in **all** classes within the Freshman Experience cohort. To enroll in this program, students may register on-line, by telephone, or in person. For further information, call the Counseling Center at (714) 564-6100.

FRESHMAN EXPERIENCE COURSES — SPRING 2008

TKT #	COURSE	TIME	DAYS	INSTRUCTOR	ROOM
1 3306002	English N60	10:15-12:20	MW	Bromberger K	B-5
2011683	Counseling 116	8:30 -9:55	MW	Scharf M	R-303
2 3306006	English N60	8:00-10:05	MW	Beyersdorf M	D-204
2011670	Counseling 116	10:15-11:40	MW	Nguyen T	H-207
3 3306134	English 061	9:30-11:35	TTh	Jaffray, S.	B-4
2011673	Counseling 116	12:00-1:25pm	TTh	Liken-McCann, L.	B-31
4 3306115	English 061	11:30-1:35pm	MW	Bassett, D	D-109
2011681	Counseling 116	10:00-11:25	MW	Guzman S	J-101
5 3310151	English 101	11:30-1:35pm	TTh	Mitzner,R.	B-7
2011676	Counseling 116	9:30-10:55	TTh	Kelley, M.	B-13
6 3310110	English 101	10:00-12:05pm	TTh	Huck, T.	D-20
7710002	Psychology 100	8:00-9:25	TTh	Ortiz F	D-102
2011679	Counseling 116	12:30-1:55pm	TTh	Everett, K.	B-29
7 3310116	English 101	10:15-12:20pm	MW	Martinez, D.	D-10
2011674	Counseling 116	8:00-9:25	MW	Lockhart, A.	A-215
8 3310207	English 102	11:30-1:35	TTh	Bassett D	B-6
9 3310308	English 103	8:00-10:05	TTh	Grunkemeyer, C	D-213
2011680	Counseling 116	11:00-12:25	T Th	Pichardo D	A-203
10 U-LINK					
3310375	English 103H	8:00-10:05	TTh	Patterson, K.	B-5
5211701	Interdiscp. Studies 117H	1:00-4:10	M	Wood S	D-401
2012803	Counseling 128	12:45-3:55pm	W	Zook R	A-207

TKT #	COURSE	TIME	DAYS	INSTRUCTOR	ROOM
11 U-LINK					
3310202	English 102	10:15-12:20pm	MW	Patterson, K.	B-7
2012802	Counseling 128	12:45-3:55pm	W	Pratt L	A-130
12 U-LINK					
1410902	Chemistry 109	1:00-2:25pm	MW	Kelcher M	R-126
	Chemistry 109L	3:00-6:10pm	M	Kelcher M	R-309
2012801	Counseling 128	9:00-10:25	MW	Zook R	B-29
13 PUENTE					
3310105	English 101	10:15-12:20pm	TTh	Martinez, D.	D-213
2011101	Counseling 111	12:30-1:25pm	T	Sanabria, R.	C-202
14 6306031	Math 060	10:15-12:20pm	MW	Rogers N	H-105
2011671	Counseling 116	9:00-12:10pm	F	Guillen, D	A-209
15 6306008	Math 060	7:45-9:50	TTh	Marecek L	H-105
2011675	Counseling 116	10:00-11:25	TTh	Robledo, R.	B-31
16 6308009	Math 080	12:15-2:45pm	MW	Vu Y	R-114
2011677	Counseling 116	10:30-11:55	MW	Campos J	J-101
17 6310508	Math 105	3:15-5:20	MW	Bowers C	H-107
2011672	Counseling 116	5:30-6:55pm	MW	Blake S	R-115
18 6314006	Math 140	9:15-11:20	TTh	Root A	H-107
2011682	Counseling 116	11:30-12:55pm	TTh	Turner E	B-13

LEARNING COMMUNITIES II

Learning Communities Aren't Just for Freshmen!

Following up on six years of increased students success in Freshman Experience learning communities, Santa Ana College is now offering a new set of learning communities opportunities: Learning Communities II.

Learning Communities II afford innovative approaches to traditional course offerings by creating linked classes in which students and instructors will explore subjects, themes, and academic skills and competencies that are common to both classes.

Note: Students are required to enroll in **all** classes within the Learning Communities II cohort. To enroll in this program, students may **register online, by telephone or in person.**

For further information, call the Counseling Center at (714) 564-6100.

LEARNING COMMUNITIES II — SPRING 2008

TKT #	COURSE	TIME	DAYS	INSTRUCTOR	ROOM
1 MESA					
6317003	Math 170	12:30-3:00pm	MW	Sill K	H-107
2011102	Counseling 111	9:00-10:50	F	Plum C	H-105
2 MESA					
1421902	Chemistry 219	9:30-10:55	MW	McMillan J	R-126
	Chemistry 219L	9:00-12:10pm	TTh	McMillan,J	R-309
2011110	Counseling 111	9:00-10:50	F	Scharf M.	R-303
3 8710122	Speech 101	9:30-10:55	TTh	Fondren S	P-114
2011108	Counseling 111	8:30-9:25	T	Robledo R	P-114



Business Administration Degree

Evening classes offered for working adults who can earn more money on their job with a college degree. Your FAAsT TRAAck program is already designed and the classes are waiting for your enrollment. The program is designed to meet the degree requirements for an Associate in Arts—Business Administration and satisfies the requirements for transfer.

First step is to contact the FAAsT TRAAck office.

Santa Ana College—Office R-118

(714) 564-6224

- **Financial Aid Available**
- **Online, Television and Classroom Courses**
- **Work for Books Program Available**

TKT#	TIME	DAYS	INSTRUCTOR	LOC./RM.	DATES
------	------	------	------------	----------	-------

ACCOUNTING

ACCOUNTING 010, ACCOUNTING PROCEDURES 3 UNITS

Emphasizes the basic accounting cycle including related financial statements and an introduction to the adjustment process. Designed for the occupationally oriented student or those preparing for Accounting 100A, 100B or 101.

0101001	9:30-10:55	TTh	Hansen J	SAC A-203	Full Semester
0101002	7:00-10:10pm	W	Hansen J	SAC A-211	Full Semester

ACCOUNTING 032, ACCOUNTING FOR PAYROLL, SALES TAX AND WORKERS' COMPENSATION 1 UNIT

How to account for payroll, sales tax, and Workers' Compensation. Forms, deposit requirement, and related information.

\$2.00 material fee required for this course at registration.

0103201	4:45-6:50pm	M	Bloom M	SAC A-222	2/11-3/31
0103202	4:45-6:50pm	M	Bloom M	SAC A-222	4/14-6/2

ACCOUNTING 035, QUICKBOOKS 1.5 UNITS

Preparation of accounting records for a business using the QuickBooks software in the Windows environment. Topics included are setup, accounts receivable, accounts payable, merchandise, payroll, and reports.

\$2.00 material fee required for this course at registration.

0103505	12:00-1:35pm	W	Shain S	SAC A-222	2/13-4/2
AND	2 Hrs Arr		Shain S	SAC WEB	
(Online instruction plus mandatory on-campus meeting every Wed 12-1:35pm. SAC A-222)					
0103506	12:00-1:35pm	W	Shain S	SAC A-222	4/16-6/4
AND	2 Hrs Arr		Shain S	SAC WEB	
(Online instruction plus mandatory on-campus meeting every Wed 12-1:35pm, SAC A-222)					
0103502	7:00-10:25pm	M	Bloom M	SAC A-228	2/11-3/31
0103503	7:00-10:25pm	M	Bloom M	SAC A-228	4/14-6/2

ACCOUNTING 101, FINANCIAL ACCOUNTING (CAN BUS 2) (CAN BUS SEQ A = ACCT 101 + 102) 4 UNITS

Financial accounting for the business administration transfer student. The accounting cycle, asset and liability accounting, partnerships, corporations, statements and principles.

0110109	8:00-10:05	MW	Mitchell E	SAC A-211	Full Semester
0110104	8:00-10:05	TTh	Staff	SAC A-209	Full Semester
0110102	8:00-12:15pm	S	Muise M	SAC A-211	Full Semester
0110116	9:30-11:35	MW	Shain S	SAC A-208	Full Semester
0110105	10:00-12:05pm	TTh	Shain S	SAC A-211	Full Semester
0110101	11:45-1:50pm	MW	Trone J	SAC A-209	Full Semester
0110113	12:15-2:20pm	TTh	Shain S	SAC A-211	Full Semester
0110107	6:00-10:15pm	M	Bloom G	SAC A-211	Full Semester
0110110	6:00-10:15pm	T	Bloom G	SAC A-211	Full Semester
0110111	6:00-10:15pm	W	Mitchell E	SAC A-209	Full Semester
0110115	6:00-10:15pm	Th	Grooms M	SAC A-211	Full Semester

ACCOUNTING 102, MANAGERIAL ACCOUNTING (CAN BUS 4) (CAN BUS SEQ A = ACCT 101 + 102) 4 UNITS

Managerial accounting for the business administration transfer student. Manufacturing and cost accounting, and the managerial uses of accounting information. Standard costs, budgets, activity based costing and capital budgeting decisions. Prerequisite: Accounting 101 or 101H.

0110210	8:00-12:15pm	S	Mitchell E	SAC A-209	Full Semester
0110204	9:30-11:35	W	Trone J	SAC A-209	Full Semester
AND	2 Hrs Arr		Trone J	SAC WEB	
(Online instruction plus mandatory on-campus meetings. Students must attend every Wed, 9:30-11:35, SAC A-209. Students must attend first week of class.)					
0110203	10:15-12:20pm	MW	Mitchell E	SAC A-211	Full Semester
0110202	10:15-12:20pm	TTh	Trone J	SAC A-209	Full Semester
0110207	6:00-10:15pm	T	Phung T	SAC A-207	Full Semester
0110205	6:00-10:15pm	Th	Phung T	SAC A-210	Full Semester

ACCOUNTING 102H, HONORS MANAGERIAL ACCOUNTING 4 UNITS

An enriched and intensive study of managerial accounting for business administration honors transfer students, emphasizing student-oriented exploration of cost accounting, and the managerial uses of accounting information. Prerequisite: Accounting 101 or 101H; and a high school or college GPA of 3.0 or above.

0110231	1:00-3:05pm	MW	Mitchell E	SAC A-211	Full Semester
---------	-------------	----	------------	-----------	---------------

ACCOUNTING 104, FEDERAL & CALIFORNIA TAXES 4 UNITS

To teach the preparation of federal and California state income tax returns for the individual. Includes Schedules A, B, C, D, E, and common income adjustments.

Accounting 104 is a CTEC-approved course which fulfills the 60-hour "qualifying education" requirement for tax preparers. A listing of additional requirements to register as a tax preparer may be obtained on the Internet at www.ctec.org.

0110401	6:00-10:10pm	W	Siebert P	DMC-203	Full Semester
0110403	6:00-10:15pm	Th	Matheny R	SAC A-209	Full Semester
0110402	Hrs Arr		Trone J	SAC WEB	Full Semester
(Orientation Thurs, Feb 14, 12pm and/or Wed, Feb 13, 6:30pm, SAC A-108. See Online Courses page in class schedule or go to www.sac.edu/disted for more information. Email instructor first week of class.)					
0110404	Hrs Arr		Trone J	SAC WEB	Full Semester
(Orientation Thurs, Feb 14, 12pm and/or Wed, Feb 13, 6:30pm, SAC A-108. See Online Courses page in class schedule or go to www.sac.edu/disted for more information. Email instructor first week of class.)					

TKT#	TIME	DAYS	INSTRUCTOR	LOC./RM.	DATES
------	------	------	------------	----------	-------

ACCOUNTING 110, FINANCIAL ACCOUNTING INTERACTIVE LAB 1 UNIT

A computer simulation that allows students to review financial accounting principles and practices in an interactive computer program. Suggested preparation: completion of, or concurrent enrollment in any financial accounting course.

\$2.00 material fee required for this course at registration.					
0111001	12:30-2:00pm	M	Shain S	SAC A-222	Full Semester
OR	1:45-2:55pm	W	Shain S	SAC A-222	
OR	5:00-6:55pm	T	Bloom M	SAC A-222	

ACCOUNTING 111, MANAGERIAL ACCOUNTING INTERACTIVE LAB 1 UNIT

Simulation that allows students to review managerial accounting principles and practices in an interactive computer program. Suggested preparation: completion of, or concurrent enrollment in, any managerial or cost accounting course.

\$2.00 material fee required for this course at registration.					
0111101	12:30-2:00pm	M	Shain S	SAC A-222	Full Semester
OR	1:45-2:55pm	W	Shain S	SAC A-222	
OR	5:00-6:55pm	T	Bloom M	SAC A-222	

ACCOUNTING 112, INTERMEDIATE ACCOUNTING LAB 1 UNIT

A computer simulation that allows students to review intermediate accounting principles and practices in an interactive computer program. Suggested preparation: completion of, or concurrent enrollment in any accounting course.

\$2.00 material fee required for this course at registration.					
0111201	12:30-2:00pm	M	Shain S	SAC A-222	Full Semester
OR	1:45-2:55pm	W	Shain S	SAC A-222	
OR	5:00-6:55pm	T	Bloom M	SAC A-222	

ACCOUNTING 121, EXCEL LAB FOR FINANCIAL ACCOUNTING 1 UNIT

A course designed to increase the financial accounting skills and knowledge of vocational and transfer accounting students by applying the Excel spreadsheet program to financial accounting. Recommended completion of, or concurrent enrollment in Accounting 010 or 101, and knowledge of basic Excel functions.

\$2.00 material fee required for this course at registration.					
0112101	12:30-2:00pm	M	Shain S	SAC A-222	Full Semester
OR	1:45-2:55pm	W	Shain S	SAC A-222	
OR	5:00-6:55pm	T	Bloom M	SAC A-222	

ACCOUNTING 122, EXCEL LAB FOR MANAGERIAL AND COST ACCOUNTING 1 UNIT

A course designed to increase the accounting skills and knowledge of vocational and transfer students by applying the Excel spreadsheet program to managerial and cost accounting. Recommended completion of, or concurrent enrollment in Accounting 102, and knowledge of basic Excel functions.

\$2.00 material fee required for this course at registration.					
0112201	12:30-2:00pm	M	Shain S	SAC A-222	Full Semester
OR	1:45-2:55pm	W	Shain S	SAC A-222	
OR	5:00-6:55pm	T	Bloom M	SAC A-222	

ACCOUNTING 123, EXCEL LAB INTERMEDIATE ACCOUNTING 1 UNIT

A course designed to increase the intermediate financial accounting skills and knowledge of vocational and transfer accounting students by applying the Excel spreadsheet program to intermediate accounting. Completion of or concurrent enrollment in Accounting 205 is recommended.

0112301	12:30-2:00pm	M	Shain S	SAC A-222	Full Semester
OR	1:45-2:55pm	W	Shain S	SAC A-222	
OR	5:00-6:55pm	T	Bloom M	SAC A-222	

ACCOUNTING 124, INCOME TAX ACCOUNTING LAB 1 UNIT

This course enhances a student's knowledge of basic income tax preparation, planning and income tax research skills, using exercises and problems. Tax returns will be prepared using computer software applications for income taxes. Recommended completion of Accounting 010 or 101 and Accounting 104.

0112401	12:30-2:00pm	M	Shain S	SAC A-222	Full Semester
OR	1:45-2:55pm	W	Shain S	SAC A-222	
OR	5:00-6:55pm	T	Bloom M	SAC A-222	

ACCOUNTING 160, COMPUTERIZED ACCOUNTING WITH MAS 90 - PART 1 CORE MODULES 3 UNITS

Hands-on training in the use of MAS 90 integrated accounting software, covering setup and transaction processing for the three core modules: General Ledger, Accounts Payable and Accounts Receivable. Suggested preparation: Completion of a basic accounting course or practical accounting experience.

\$4.00 material fee required for this course at registration.					
0116001	7:00-10:15pm	T	Bloom M	SAC A-228	Full Semester

SANTA ANA COLLEGE

FIRST CLASS MEETING

Make sure you attend the first class meeting!

Attendance at the first meeting of a class is advised because of enrollment demands. Any student not reporting to the first class meeting may be dropped from the roll sheet.

TKT#	TIME	DAYS	INSTRUCTOR	LOC./RM.	DATES
ACCOUNTING 205, INTERMEDIATE ACCOUNTING 3 UNITS					
Second-year accounting dealing with concepts and financial statements, present and future value, cash, investments, receivables, cost and valuation procedures for inventories, and plant and intangible assets. Prerequisite: Accounting 102 or 102H.					
0120501	6:00-9:10pm	M	Mitchell E	SAC A-209	Full Semester

ARCHEOLOGY (SEE ANTHROPOLOGY)

ANTHROPOLOGY

ANTHROPOLOGY 100, INTRODUCTION TO CULTURAL ANTHROPOLOGY 3 UNITS					
The exploration of anthropology as a way of understanding what humankind shares in common and how and why humans are diverse. Includes contemporary issues such as gender and ethnic diversity, cultural change, and globalization.					
0210007	8:00-9:25	TTh	Cundiff W	SAC D-401	Full Semester
0210001	8:00-11:35	MTWTh	Wood S	SAC D-401	1/8-1/31
0210013	9:45-11:10	MW	Robertson M	SAC D-401	Full Semester
0210014	9:45-11:10	TTh	Morales A	SAC D-401	Full Semester
0210011	6:00-9:10pm	F	Arden J	SAC D-401	4/18-6/7
AND	9:00-12:10pm	S	Arden J	SAC D-401	
0210010	7:00-10:10pm	M	Morales A	SAC D-401	Full Semester
0210003	7:00-10:10pm	Th	Royston III C	SAC D-401	Full Semester
0210015	Hrs Arr		Light L	SAC WEB	Full Semester
(Tckt No 0210015 requires on-campus meetings: Mon, Feb 11, Mar 3, Mar 24, Apr 28, May 19, 4-5:50pm, SAC D-103. See Online Courses page in class schedule or go to www.sac.edu/disted for more information.)					
0210081	Hrs Arr		Light L	SAC TV	Full Semester

ANTHROPOLOGY 100H, HONORS INTRODUCTION TO CULTURAL ANTHROPOLOGY 3 UNITS					
Seminar style, content enriched for honors students. A critical and extensive exploration of cultural anthropology, including contemporary issues and debates. Prerequisite: A high school or college GPA of 3.0 or above.					
0210031	1:00-4:35pm	MTWTh	Wood S	SAC D-401	1/8-1/31

ANTHROPOLOGY 101, INTRODUCTION TO PHYSICAL ANTHROPOLOGY (CAN ANTH 2) 3 UNITS					
Introduction to humankind's place in nature, including evolutionary theory, principles of genetics, primate behavior, the fossil record, growth and adaptability, human variation, and biomedical anthropology. Application of biological anthropology to contemporary human problems.					
0210109	8:00-9:25	MW	Wood S	SAC D-401	Full Semester
0210105	11:30-12:55pm	MW	Robertson M	SAC D-401	Full Semester
0210102	11:30-12:55pm	TTh	Robertson M	SAC D-401	Full Semester
0210101	7:00-10:10pm	T	Cundiff W	SAC D-214	Full Semester

ANTHROPOLOGY 101L, PHYSICAL ANTHROPOLOGY LABORATORY 1 UNIT					
Lab exercises and experiments to study the major areas of physical anthropology: evolutionary theory, genetics, nonhuman primate anatomy and behavior, fossil identification, human biology and variation, growth and adaptability, and infectious diseases. Prerequisite: Anthropology 101 or concurrent enrollment.					
0210106	1:30-4:40pm	W	Robertson M	SAC D-401	Full Semester
0210110	1:30-4:40pm	Th	Robertson M	SAC D-401	Full Semester
0210107	7:00-10:10pm	W	Robertson M	SAC D-401	Full Semester

ANTHROPOLOGY 108, RELIGION, MAGIC, AND WITCHCRAFT 3 UNITS					
An introduction to the anthropology of religion, magic, and witchcraft. A cross cultural study focusing on the beliefs and practices of early, non-western, and traditional religious systems with emphasis on the forms, functions, structures, symbolism, history, and evolution.					
0210801	7:00-10:10pm	T	Robertson M	SAC D-401	Full Semester

ART

DMC as a room indicator in this schedule refers to the new Digital Media Center located at 1300 S. Bristol Street, Santa Ana, California.

ART 009, ART LAB 0.5 UNITS					
Open lab session designed for studio art students to put additional hours on projects. Projects, determined by class assignment, vary each semester. Open entry/open exit. May be repeated. Grade: CR/NCR only.					
0600901	9:00-12:05pm	F	Crabb P	SAC C-105	Full Semester
0600902	12:30-3:40pm	S	Art Staff	SAC C-105	Full Semester
0600905	5:15-6:20pm	MW	Orr E	SAC C-210	Full Semester

ART 030, BASIC DRAWING 1.5 UNITS					
Basic introduction to the fundamentals of drawing. Explores a variety of techniques and media such as graphite, charcoal and ink. Utilization of man-made and natural forms as subject matter.					
0603009	9:00-12:10pm	S	Hower T	SAC C-210	Full Semester
0603006	9:30-12:40pm	M	Wagstaff J	SAC C-210	Full Semester
0603001	9:30-12:40pm	T	Miller R	SAC C-210	Full Semester
0603004	1:00-4:10pm	T	Genoway K	SAC C-210	Full Semester
0603008	2:00-5:10pm	M	Lee D	SAC C-208	Full Semester
0603007	6:30-9:40pm	M	Leysen M	SAC C-208	Full Semester

digital media center

1300 S. Bristol St., just 1 mile south of the main campus

New home of the SAC TV/Video department,
Design Works and PSI/Business Seminars

Digital Media Arts	Broadcast Journalism
Digital Music	Business Courses
TV/Video Production	PSI / Business Seminars

ART 031A, INTRODUCTION TO LIFE DRAWING 1.5 UNITS					
Basic introduction to drawing the human figure utilizing the live model. Elements of structure, anatomy and portraiture are presented while exploring fundamental drawing techniques. Art 030 or 130 recommended.					
0603101	6:30-9:40pm	T	Duplessis D	SAC C-210	Full Semester

ART 033, DRAWING IN PASTEL 1.5 UNITS					
Introduction to the materials and techniques of pastel drawing. Presents fundamentals of color theory while developing drawing skills and concepts.					
0603302	9:00-12:05pm	F	Hardy K	SAC C-210	Full Semester

ART 040, BASIC WATERCOLOR 1.5 UNITS					
Fundamentals of transparent watercolor techniques such as wet in wet, dry brush, overlays, washes. Form, composition, basic color theory and basic sketching are included. May be repeated. Prerequisite: Art 030.					
0604001	6:00-9:10pm	T	Genoway K	SAC C-106	Full Semester

ART 041, INTRODUCTION TO PAINTING 1.5 UNITS					
Introduction to the fundamentals of oil and/or acrylic painting including materials and basic techniques of the painter. Color theory and composition are studied while painting a variety of subject matter and styles.					
0604102	2:00-5:10pm	M	Orr E	SAC C-210	Full Semester
0604103	6:30-9:40pm	M	Orr E	SAC C-210	Full Semester

Materials (such as clay, glass, canvas, paper and photographic supplies) used in creating individual class-assigned projects must be purchased by the student. Please consult with your studio art instructor for specific information regarding your class, and about where and how to buy materials.

ART 051, CERAMICS-BASIC LEVEL 1.5 UNITS					
Exploration of elementary properties of clay, glazes, terminology, tools, and equipment. Enables student to create wheel-thrown and hand-built forms. Emphasizes creative design with both aesthetic and utilitarian functions. Students provide own clay and tools.					
\$15.00 material fee required for this course at registration.					
0605102	9:00-12:10pm	S	Art Staff	SAC C-105	Full Semester
0605101	1:00-4:10pm	W	Crabb P	SAC C-105	Full Semester

ART 084, GLASS BLOWING LABORATORY 1 UNIT					
Scheduled lab sessions for development of glass blowing techniques. 48 hours earn 1 unit. Open entry/open exit. May be repeated. Grade: CR/NCR only. Prerequisite: Concurrent enrollment in Art 184A or 184B.					
0608401	48 Hrs Arr		Williams M	SAC C-106	Full Semester

ART 100, INTRODUCTION TO ART CONCEPTS 3 UNITS					
A study of the visual arts in relation to both personal and cultural expressions. Fundamentals of visual organization, color theory, terminology, historical art movements and concepts will be studied. Required for art majors.					
0610013	8:00-9:25	MW	Leysen M	SAC C-104	Full Semester
0610007	8:00-9:25	TTh	Redfield M	SAC C-104	Full Semester
0610009	9:00-12:10pm	F	Di Michele D	SAC C-104	Full Semester
0610001	9:00-1:15pm	TWTh	Soriano I	SAC A-210	1/8-1/31
0610011	11:00-12:25pm	TTh	Wildermuth L	SAC C-104	Full Semester
0610003	12:30-1:55pm	MW	Lee D	SAC C-104	Full Semester
0610008	1:00-2:25pm	TTh	Soriano I	SAC C-104	Full Semester
0610050	6:00-10:05pm	TWTh	Redfield M	SAC A-130	1/8-1/31
0610004	6:00-10:05pm	F	Redfield M	SAC A-130	4/18-5/24
AND	12:30-4:35pm	S	Redfield M	SAC A-130	
0610005	6:30-9:40pm	W	Soriano I	SAC C-104	Full Semester
0610006	Hrs Arr		Redfield M	SAC WEB	Full Semester
(See online courses page in class schedule, or go to www.sac.edu/disted for more information)					
0610099	Hrs Arr		Wildermuth L	SAC WEB	Full Semester
(See Online Courses page in class schedule or go to www.sac.edu/disted for more information)					

TKT#	TIME	DAYS	INSTRUCTOR	LOC./RM.	DATES
------	------	------	------------	----------	-------

**ART 101, SURVEY OF WESTERN ART HISTORY (CAN ART 2)
(CAN ART SEQ A = ART 101+102) 3 UNITS**

The study of art through the Middle Ages. Cultures and civilizations are studied through slides, films, lectures, discussion and reading. Required for art majors.

0610102	Hrs Arr		Wildermuth L	SAC WEB	Full Semester
(See online courses page in class schedule, or go to www.sac.edu/disted for more information)					
0610103	9:30-10:55	MW	Wildermuth L	SAC C-104	Full Semester

**ART 102, WESTERN ART HISTORY (CAN ART 4)
(CAN ART SEQ A = ART 101+102) 3 UNITS**

A study of art movements, painters, sculptors, and architects and printmakers from the Renaissance through the modern period. Required for art majors.

0610201	9:30-10:55	TTh	Soriano I	SAC C-207	Full Semester
0610202	6:30-9:40pm	W	Wildermuth L	SAC C-213	Full Semester

ART 103, AFRICAN ART HISTORY 3 UNITS

History and appreciation of the traditional arts of African tribes and kingdoms. Considers religious beliefs, general cultural patterns, impact of African art on Western art, African-American art in Latin America, and the U.S.A., including the 20th century.

0610301	11:00-12:25pm	MW	Brown W	SAC C-207	Full Semester
---------	---------------	----	---------	-----------	---------------

ART 104, MEXICAN & CHICANO ART HISTORY 3 UNITS

History and appreciation of Mexican and Chicano art, pre-Columbian to the present, including the modern murals of Mexico and the United States.

0610405	9:30-10:55	MW	Soriano I	SAC A-130	Full Semester
0610406	11:00-12:25pm	TTh	Soriano I	SAC A-210	Full Semester
0610402	6:30-9:40pm	M	Soriano I	SAC C-104	Full Semester

ART 105, HISTORY OF MODERN ART 3 UNITS

History and appreciation of painting, sculpture, architecture, prints and applied arts from the late nineteenth century through the twentieth century.

0610501	7:00-10:15pm	T	Jaffray S	SAC C-213	Full Semester
---------	--------------	---	-----------	-----------	---------------

ART 106, ASIAN ART HISTORY 3 UNITS

Historical survey of the visual arts of China, Japan, India and Southeast Asia. Includes relationship of Far Eastern philosophy and culture to artistic achievement. Emphasizes works of art, in terms of style, technique and content.

0610603	9:00-12:15pm	F	Fosmire E	SAC C-214	Full Semester
---------	--------------	---	-----------	-----------	---------------

ART 110, TWO-DIMENSIONAL DESIGN (CAN ART 14) 3 UNITS

Study of basic principles of visual organization and color theory. Application of concepts through creative projects. Required for art majors.

0611001	9:15-12:25pm	MW	Di Michele D	SAC C-208	Full Semester
0611004	6:30-9:40pm	TTh	Hostetter D	SAC C-208	Full Semester

ART 111, THREE-DIMENSIONAL DESIGN (CAN ART 16) 3 UNITS

Fundamentals of visual organization as applied to objects-in-the-round. Creative projects in various media. Required for art majors.

0611101	9:30-12:40pm	TTh	Hassold L	SAC C-106	Full Semester
---------	--------------	-----	-----------	-----------	---------------

ART 115, ART FORUM: ISSUES IN CONTEMPORARY ART 1 UNIT

Dialogue among artists, critics, students and faculty on issues and problems in art from the mid 20th century to the present. Topics differ each semester. Two semesters (2 units) required for art majors. May be repeated. Grade: CR/NCR only.

0611503	12:30-1:55pm	M	Lee D	SAC C-104	Full Semester
---------	--------------	---	-------	-----------	---------------

ART 121A, FUNDAMENTALS OF TYPOGRAPHY 3 UNITS

Introduction to the fundamentals of typography with regard to current aesthetics in the use of type for visual communication. Study of current graphics industry practices and standards, including the use of digital technology and traditional hand skills. Art 110 recommended. Prerequisite: Art 195.

\$15.00 material fee required for this course at registration.

0612101	7:00-10:10pm	TTh	Tani K	SAC A-219	Full Semester
---------	--------------	-----	--------	-----------	---------------

ART 121B, ADVANCED TYPOGRAPHY 3 UNITS

Provides continued study of typography as a means for solving complex graphic design problems, using traditional hand skills, digital technology and portfolio presentations. Prerequisite: Art 121A.

\$15.00 material fee required for this course at registration.

0612102	7:00-10:10pm	TTh	Tani K	SAC A-219	Full Semester
---------	--------------	-----	--------	-----------	---------------

TKT#	TIME	DAYS	INSTRUCTOR	LOC./RM.	DATES
------	------	------	------------	----------	-------

Are you interested in meeting prominent California artists? Would you like to be a part of a special group of students that has opportunities to visit exhibiting artists' studios, arrange their artwork in our gallery, and give guided tours to visitors? These and other activities are part of this laboratory class. Work on one exhibit or several in this open entry / open exit class.

ART 124, GALLERY PRODUCTION 0.5-2 UNITS

Instruction in preparation and installation of art exhibits, gallery management, and working on a museum exhibition staff. Includes lectures, visits to artists' studios, and opportunities to work on art shows in two college galleries. Field trips include visits to local galleries and behind-the-scenes museum tours of collections and exhibition preparation areas. Open entry/open exit. May be repeated. Grade: CR/NCR only.

0612401	Hrs Arr		Marquez P	SAC C-106	Full Semester
---------	---------	--	-----------	-----------	---------------

GALLERY PRODUCTION - ART 124

Orientation meeting for all Gallery Production students is WEDNESDAY, Feb 13, 12:30-1:20pm in the Gallery SAC C-101. Course content and arranged hours will be discussed. If you are unable to attend orientation, notify the Art Gallery office, 714-564-5615 or staff in the Fine and Performing Arts Division office, 714-564-5600.

ART 129, GRAPHIC DESIGN CONCEPTS FOR THE WEB 3 UNITS

Introduction to graphic design concepts for Web. Includes learning technical aspects of Web safe colors, file optimization, effects, images, slicing, rollovers, and applying the elements and principles of design. Includes creative Web design projects. Photoshop skills recommended. (Same as Computer Science 155.)

\$4.00 material fee required for this course at registration.

0612903	9:00-1:15pm	F	Waterman P	SAC A-219	Full Semester
0612904	4:00-6:05pm	TTh	Nielsen C	DMC-104	Full Semester

ART 130, INTRODUCTION TO DRAWING (CAN ART 8) 3 UNITS

Introductory course in expressive drawing, exploring line, form, composition and a variety of media. Drawing from man-made objects and natural forms. Required for art majors.

0613007	9:00-12:10pm	S	Hower T	SAC C-210	Full Semester
AND	12:40-3:50pm	S	Hower T	SAC C-210	Full Semester
0613009	9:30-12:40pm	MW	Wagstaff J	SAC C-210	Full Semester
0613001	9:30-12:40pm	TTh	Miller R	SAC C-210	Full Semester
0613004	1:00-4:10pm	TTh	Genoway K	SAC C-210	Full Semester
0613005	2:00-5:10pm	MW	Lee D	SAC C-208	Full Semester
0613008	6:30-9:40pm	MW	Leysen M	SAC C-208	Full Semester

ART 131, BEGINNING LIFE DRAWING 3 UNITS

Introduction to drawing of the human form utilizing the live model following traditional and contemporary approaches. Required for art majors. Art 030 or 130 recommended.

0613101	6:30-9:40pm	TTh	Duplessis D	SAC C-210	Full Semester
---------	-------------	-----	-------------	-----------	---------------

ART 132A, BEGINNING PASTEL DRAWING AND PAINTING 3 UNITS

Pastel drawing and painting techniques. Color theory, value, composition emphasized. Preparation of grounds using various papers. Study of contemporary and historical styles and techniques. Prerequisite: Art 130.

0613202	9:00-3:30pm	F	Hardy K	SAC C-210	Full Semester
---------	-------------	---	---------	-----------	---------------

ART 132B, INTERMEDIATE PASTEL DRAWING AND PAINTING 3 UNITS

Contemporary uses of pastels. Intermediate and advanced projects emphasizing pastel drawing/painting, in conjunction with other media. Emphasis on contemporary art concepts, personal expression and style. Prerequisite: Art 132A.

0613299	9:00-3:30pm	F	Hardy K	SAC C-210	Full Semester
---------	-------------	---	---------	-----------	---------------

ART 137A, INTRODUCTION TO AIRBRUSH 1.5 UNITS

A basic study of airbrush techniques, materials, media and styles. An emphasis will be placed on skill development and preparation of portfolio material.

0613701	9:00-12:10pm	S	Sagen A	SAC C-208	Full Semester
---------	--------------	---	---------	-----------	---------------

ART 137B, INTERMEDIATE AIRBRUSH 1.5 UNITS

Additional study of airbrush techniques, materials, media and applications. Emphasizes further skill development of portfolio material. Prerequisite: Art 137A.

0613702	9:00-12:10pm	S	Sagen A	SAC C-208	Full Semester
---------	--------------	---	---------	-----------	---------------

ART 140A, WATERCOLOR PAINTING 2 UNITS

A study of fundamental approaches to the use of transparent watercolor. Fine art and commercial techniques and applications are included. Prerequisite: Art 130.

0614001	6:00-10:15pm	T	Genoway K	SAC C-106	Full Semester
---------	--------------	---	-----------	-----------	---------------

ART 140B, WATERCOLOR PAINTING 2 UNITS

Further study in the use of transparent and opaque watercolor techniques. Expressive painting for both fine art and commercial uses. Prerequisite: Art 140A.

0614002	6:00-10:15pm	T	Genoway K	SAC C-106	Full Semester
---------	--------------	---	-----------	-----------	---------------

ART 141, BEGINNING PAINTING 3 UNITS

Introduction to acrylic and/or water soluble oil painting designed to develop basic painting skills. Course content includes composition and color theory, materials, tools, techniques, and the study of traditional and contemporary painting styles. Art 030, 110, and 130 recommended.

0614102	2:00-5:10pm	MW	Orr E	SAC C-210	Full Semester
0614103	6:30-9:40pm	MW	Orr E	SAC C-210	Full Semester

Can't find the class you need?
It may be waiting for you at
Santiago Canyon College!
 View SCC's class schedule at
www.sccollege.edu/schedule
 SCC's class schedule is included in this booklet.
Hurry! Class sizes are limited.

Creative Ceramics



Pottery Wheel Making and Hand Building Construction Beginning to Advanced Levels

ART 150, PRIMITIVE POTTERY TECHNIQUES 3 UNITS

Primitive techniques in pottery construction and firing. Emphasizes handbuilt forms. Students will construct tools. Sawdust, raku, dung, low temperature salt and other pit firings utilized. 3-day desert campout with pit firings, (optional).

0615002	1:00-4:10pm	MW	Crabb P	SAC C-105	Full Semester
0615001	7:00-10:10pm	TTh	Crabb P	SAC C-105	Full Semester

ART 151, CERAMICS-INTRODUCTORY LEVEL (CAN ART 6) 3 UNITS

Exploration of clay as a structural and creative material, including throwing on the wheel, handbuilding, surface design and glazing. Students provide own clay and tools.

\$15.00 material fee required for this course at registration.

0615101	9:00-12:10pm	MW	Crabb P	SAC C-105	Full Semester
0615102	9:00-12:10pm	S	Art Staff	SAC C-105	Full Semester
AND	12:30-3:40pm	S	Art Staff	SAC C-105	
0615103	7:00-10:10pm	TTh	Crabb P	SAC C-105	Full Semester

ART 152, CERAMICS-INTERMEDIATE THROWING 3 UNITS

Further study of wheel thrown techniques with an emphasis on functional, utilitarian forms. Introduction to glaze chemistry. Students provide own clay and tools. Prerequisite: Art 151.

\$15.00 material fee required for this course at registration.

0615201	7:00-10:10pm	TTh	Crabb P	SAC C-105	Full Semester
---------	--------------	-----	---------	-----------	---------------

ART 153, CERAMICS-INTERMEDIATE HANDBUILDING 3 UNITS

Further study of handbuilding techniques, with emphasis on sculptural forms. Non-traditional alternatives to glazing explored. Students provide own clay and tools. Prerequisite: Art 151.

\$15.00 material fee required for this course at registration.

0615302	9:00-12:10pm	MW	Crabb P	SAC C-105	Full Semester
---------	--------------	----	---------	-----------	---------------

ART 162, DIGITAL DESIGN WITH PHOTOSHOP-I 3 UNITS

An introduction to using Photoshop for Web, print, CD and 3D. Instruction in capturing, manipulating, and outputting images. Focus on basic skills and techniques for editing and enhancing photographs, manipulating scanned images and creating digital graphics. Application of technology skills using design to create digital composites. Prerequisite: Art 195 or portfolio approval.

\$15.00 material fee required for this course at registration.

0616201	10:00-1:15pm	TTh	Brown S	DMC-104	Full Semester
0616203	7:00-10:15pm	MW	Caterina Barrett A	SAC A-219	Full Semester

ART 163, DIGITAL DESIGN WITH PHOTOSHOP-II 3 UNITS

Intermediate production oriented applications of Photoshop to create portfolio. Instruction techniques for color, restoration, effects. Exploration of 3D scanning, negative manipulation, and image preparation for print and web. Research on artist's portfolios. May be repeated. Prerequisite: Art 162 or portfolio approval.

\$15.00 material fee required for this course at registration.

0616301	10:00-1:15pm	TTh	Brown S	DMC-104	Full Semester
0616303	7:00-10:15pm	MW	Caterina Barrett A	SAC A-219	Full Semester

TKT#	TIME	DAYS	INSTRUCTOR	LOC./RM.	DATES
------	------	------	------------	----------	-------

ART 164, WEB DESIGN WITH FLASH 3 UNITS

Introduction to Multimedia tools; graphics, text, sound, motion, using Flash software. Students research how Flash is used in business presentations, advertising, entertainment, and self-promotion. Overview of elements and principles of design and motion. May be repeated. Prerequisite: Art 129 or 195 or 229 or Computer Science 155 or 156 or portfolio approval.

\$10.00 material fee required for this course at registration.

0616401	9:00-12:15pm	F	Art Staff	DMC-104	Full Semester
---------	--------------	---	-----------	---------	---------------

ART 168, DIGITAL MEDIA: PORTFOLIO AND BUSINESS STRATEGIES 3 UNITS

Creation of digital portfolio, for career and business. Students will identify markets, define career goals, develop resume, create print/web portfolio, and develop interviewing skills. Includes business requirements for working with customers. May be repeated. Prerequisite: Art 122, 163 and 192A; or portfolio review.

\$25.00 material fee required for this course at registration.

0616801	1:00-4:15pm	MW	Brown S	DMC-104	Full Semester
---------	-------------	----	---------	---------	---------------

ART 182, INTRODUCTION TO JEWELRY 3 UNITS

Basic instruction in jewelry fabrication and casting, including silver soldering, lost wax casting, and basic stone cutting.

\$25.00 material fee required for this course at registration.

W	0618201	9:00-12:10pm	S	Monroe J	SAC C-106	Full Semester
W	AND	1:00-4:10pm	S	Monroe J	SAC C-106	

ART 184A, BEGINNING GLASS BLOWING 3 UNITS

Design development and glass blowing techniques from functional vessels to glass sculpture. Mold blowing, sandblasting, polishing, proper tool use and equipment operation. May be repeated. Prerequisite: Concurrent enrollment in Art 084.

\$125.00 material fee required for this course at registration.

0618401	1:00-3:30pm	TTh	Williams M	SAC C-106	Full Semester
---------	-------------	-----	------------	-----------	---------------

ART 184B, INTERMEDIATE GLASS BLOWING 3 UNITS

Continued design/development techniques. Mold blowing and glass sculpture using glass casting, sand blasting and painting. Lapidary techniques and polishing emphasized. Proper tool use and safe equipment operations. May be repeated. Prerequisite: Art 184A.

\$125.00 material fee required for this course at registration.

0618421	1:00-3:30pm	TTh	Williams M	SAC C-106	Full Semester
---------	-------------	-----	------------	-----------	---------------

ART 187, GLASS SLUMPING AND FUSING 1.5 UNITS

Experience glass slumping and glass fusing to create flat or 3-dimensional projects such as plates, decorative tiles, bowls, and enhanced stained glass designs. A variety of techniques will be explored including ceramic mold making, slumping, fusing and draping glass, copper or brass wire soldering, and sandblasting. May be repeated.

0618701	6:00-9:10pm	M	Freeland-Salcedo J	SAC C-106	Full Semester
---------	-------------	---	--------------------	-----------	---------------

ART 191A, DIGITAL PUBLISHING WITH INDESIGN 3 UNITS

An introduction to desktop publishing and page layouts, including experience in design and development of single and multiple page documents. Also includes advanced technique in complex documents and web-ready pages using the InDesign software on the Macintosh. May be repeated. Prerequisite: Art 195.

\$10.00 material fee required for this course at registration.

0619101	10:30-1:40pm	TTh	Baitoo H	SAC A-219	Full Semester
---------	--------------	-----	----------	-----------	---------------

ART 192A, DIGITAL ILLUSTRATION WITH ILLUSTRATOR 3 UNITS

An introduction to design and illustration techniques using the Adobe Illustrator program on the Macintosh. Instruction in commonly used professional industry topics and techniques, for print, animation and the web. May be repeated. Prerequisite: Art 195.

\$15.00 material fee required for this course at registration.

0619201	7:00-10:15pm	TTh	Nielsen C	DMC-104	Full Semester
---------	--------------	-----	-----------	---------	---------------

ART 195, INTRODUCTION TO DIGITAL MEDIA ARTS 3 UNITS

A survey of computer graphics applications and graphics techniques. Some project work required. Recommended for artists and designers.

\$10.00 material fee required for this course at registration.

0619505	8:00-10:05	TTh	Baitoo H	SAC A-219	Full Semester	
0619501	8:50-10:55	MW	Tani K	SAC A-219	Full Semester	
0619502	9:00-1:15pm	TWThF	Hostetter D	SAC A-219	1/8-2/1	
0619507	1:00-3:05pm	MW	Caterina Barrett A	SAC A-219	Full Semester	
W	0619504	6:00-10:15pm	F	Art Staff	SAC A-219	Full Semester

ART 196A, 3-D MODELING FUNDAMENTALS 2.5 UNITS

Skill development in 2-D spline drawing, 3-D modeling techniques, and scene construction using Autodesk 3-D Studio Max. Project work and other assignments created in lab. (Same as Television/Video Communications 181.) May be repeated. Prerequisite: Art 195.

0619602	6:00-10:15pm	T	Waterman P	SAC A-223	2/11-3/31
AND	5 Hrs Arr		Waterman P	SAC A-223	

ART 196B, 3-D ADVANCED MODELING TECHNIQUES 2.5 UNITS

Computer graphics image development with emphasis on advanced modeling techniques, refined surface materials, and environmental lighting techniques using 3-D Studio Max. (Same as Television/Video Communications 182.) May be repeated. Prerequisite: Art 196A or Television/Video Communications 181.

\$15.00 material fee required for this course at registration.

0619601	6:00-10:15pm	T	Waterman P	SAC A-223	4/14-6/2
AND	5 Hrs Arr		Waterman P	SAC A-223	

First Place
3D Animation
State-Wide!

3D Animation Certificate Program



Gabe Askev



Minh Do



Alex Diaz

The 3D Animation Certificate Program, prepares students for entry level 3D modeling, and animation positions for film, television, video games and architectural visualization.

ART 197A, 3-D ANIMATION FUNDAMENTALS **2.5 UNITS**
 Introduction to computer animation using 3-D motion techniques. Tutorials and projects combine to develop animation skills using 3-D Studio Max. (Same as Television/Video Communications 185.) May be repeated. Prerequisite: Art 196AB or Television/Video Communications 181, 182.

0619701	6:00-10:15pm	Th	Waterman P	SAC A-217	2/13-4/2
AND	5 Hrs Arr		Waterman P	SAC A-217	

ART 197B, 3-D ANIMATION INTERMEDIATE TECHNIQUES **2.5 UNITS**
 Continued study of computer animation techniques using 3-D Studio Max. Animation projects developed through team approach with small groups of individuals. (Same as Television/Video Communications 186.) May be repeated. Prerequisite: Art 197A or Television/Video Communications 185.

0619702	6:00-10:15pm	Th	Waterman P	SAC A-217	4/16-6/4
AND	6 Hrs Arr		Waterman P	SAC A-217	

ART 198, STORYBOARDING & CHARACTER DEVELOPMENT **2 UNITS**
 An introduction to basic character development and storyboarding as used in television, film and electronic games. The course includes sketching, inking, the development of characters, storyboard development and an overview of cartoon and storyboard history. May be repeated.

0619801	9:00-12:10pm	F	Sivertsen K	SAC C-207	Full Semester
---------	--------------	---	-------------	-----------	---------------

ART 230, INTERMEDIATE DRAWING **3 UNITS**
 Continued study in drawing with additional opportunities in graphic expression. Further explores media, including colored pencils, oil pastel, charcoal, ink and mixed media. Continues composition concepts emphasizing individual expression. Prerequisite: Art 030 or 130.

W	0623008	9:00-12:10pm	S	Hower T	SAC C-210	Full Semester
	AND	12:40-3:50pm	S	Hower T	SAC C-210	
	0623003	9:30-12:40pm	MW	Wagstaff J	SAC C-210	Full Semester
	0623001	9:30-12:40pm	TTh	Miller R	SAC C-210	Full Semester
	0623004	1:00-4:10pm	TTh	Genoway K	SAC C-210	Full Semester
	0623007	2:00-5:10pm	MW	Lee D	SAC C-208	Full Semester
	0623002	6:30-9:40pm	MW	Leysen M	SAC C-208	Full Semester

ART 231, INTERMEDIATE LIFE DRAWING **1.5-3 UNITS**
 Continued experience in drawing from the live model with opportunity for development of self expression. Further exploration of media and techniques. May be repeated. Prerequisite: Art 131.

0623101	6:30-9:40pm	TTh	Duplessis D	SAC C-210	Full Semester
---------	-------------	-----	-------------	-----------	---------------

ART 232, ADVANCED LIFE DRAWING **1.5-3 UNITS**
 Intensive study of the figure with further development of drawing skills, composition, technique and media utilizing the live model. May be repeated. Prerequisite: Art 231.

0623201	6:30-9:40pm	TTh	Duplessis D	SAC C-210	Full Semester
---------	-------------	-----	-------------	-----------	---------------

ART 233, ADVANCED DRAWING **3 UNITS**
 Students will plan a series of drawing problems to be executed during the semester under the instructor's direction. Exploration of new materials and techniques. Field trips to artists' studios, galleries, and museums. May be repeated. Prerequisite: Art 230.

W	0623309	9:00-12:10pm	S	Hower T	SAC C-210	Full Semester
	AND	12:40-3:50pm	S	Hower T	SAC C-210	
	0623301	9:30-12:40pm	MW	Wagstaff J	SAC C-210	Full Semester
	0623306	9:30-12:40pm	TTh	Miller R	SAC C-210	Full Semester
	0623304	1:00-4:10pm	TTh	Genoway K	SAC C-210	Full Semester
	0623307	2:00-5:10pm	MW	Lee D	SAC C-208	Full Semester
	0623302	6:30-9:40pm	MW	Leysen M	SAC C-208	Full Semester

ART 240, INTERMEDIATE WATERCOLOR **2 UNITS**
 A continuing course in watercolor designed to further explore media, technique, composition and conceptual interpretation through individual direction. May be repeated. Prerequisite: Art 140B.

0624001	6:00-10:15pm	T	Genoway K	SAC C-106	Full Semester
---------	--------------	---	-----------	-----------	---------------

Materials (such as clay, glass, canvas, paper and photographic supplies) used in creating individual class-assigned projects must be purchased by the student. Please consult with your studio art instructor for specific information regarding your class, and about where and how to buy materials.

ART 241, INTERMEDIATE PAINTING **1.5-3 UNITS**
 An intermediate level class designed to advance the creativity of those with basic skills in water-soluble oil or acrylic painting. Further study of new media, technique and style with traditional and contemporary references. Emphasizes individual creative problems. May be repeated. Prerequisite: Art 041 or 141.

0624102	2:00-5:10pm	MW	Orr E	SAC C-210	Full Semester
0624103	6:30-9:40pm	MW	Orr E	SAC C-210	Full Semester

ART 242, ADVANCED PAINTING **1.5-3 UNITS**
 An advanced level course promoting refinement of painting skills with emphasis on individual creative expression. Further development of style and technique. Classroom studio use of oils limited to water-soluble oil paint only. May be repeated. Prerequisite: Art 241.

0624202	2:00-5:10pm	MW	Orr E	SAC C-210	Full Semester
0624203	6:30-9:40pm	MW	Orr E	SAC C-210	Full Semester

Enrollment in ALL sections of Art 250, Advanced Studio Concepts, is an intensive study in visual arts for majors with studio emphasis, exploring contemporary directions, trends, and job markets with student projects differing each semester. Requires prior approval of the instructor.

ART 250, ADVANCED STUDIO CONCEPTS **1.5-3 UNITS**
 Intensive study in visual arts for majors with studio emphasis. Explores contemporary directions, trends and job markets. Student projects differ each semester. May be repeated.

0625051	2.5 Hrs Arr		Brown S	DMC-104	Full Semester
0625006	9:00-12:10pm	MW	Crabb P	SAC C-105	Full Semester
0625091	9:00-12:10pm	F	Sivertsen K	SAC C-207	Full Semester
0625099	9:00-3:30pm	F	Hardy K	SAC C-210	Full Semester
0625014	9:30-12:40pm	TTh	Hassold L	SAC C-106	Full Semester
0625018	1:00-3:30pm	TTh	Williams M	SAC C-106	Full Semester
0625010	1:00-4:10pm	MW	Crabb P	SAC C-105	Full Semester
0625032	2:00-5:10pm	MW	Orr E	SAC C-210	Full Semester
0625054	6:00-9:10pm	M	Freeland-Salcedo J	SAC C-106	Full Semester
0625061	6:00-10:15pm	W	Monroe J	SAC C-106	Full Semester
0625011	6:30-9:40pm	MW	Orr E	SAC C-210	Full Semester
0625013	6:30-9:40pm	MW	Leysen M	SAC C-208	Full Semester
0625001	6:30-9:40pm	TTh	Duplessis D	SAC C-210	Full Semester
0625012	7:00-10:10pm	TTh	Crabb P	SAC C-105	Full Semester

ART 268, DIGITAL MEDIA PRACTICUM **3 UNITS**
 Students work in teams to design, organize, and produce digital media projects for clients. Practical work experience in different production team roles: project leader, music designer, graphic designer, video producer/editor, print and web designers. Projects provide students with work for their portfolios. (Same as Music 268, Television/Video Communications 268.) May be repeated. Prerequisite: Art 168.

0626801	7:00-10:15pm	MW	Brown S	DMC-104	Full Semester
---------	--------------	----	---------	---------	---------------

ART 282, JEWELRY II **3 UNITS**
 Continued instruction in jewelry fabrication and casting including silver soldering, lost wax casting, wax working, enameling, mold making, and stone setting. Prerequisite: Art 182.

\$25.00 material fee required for this course at registration.

W	0628201	9:00-12:10pm	S	Monroe J	SAC C-106	Full Semester
	AND	1:00-4:10pm	S	Monroe J	SAC C-106	

TKT#	TIME	DAYS	INSTRUCTOR	LOC./RM.	DATES
------	------	------	------------	----------	-------

ART 283, JEWELRY III**3 UNITS**

Advanced instruction in jewelry fabrication and casting including reticulation, repousse, and granulation. Opportunity for work on individual projects. May be repeated. Prerequisite: Art 282.

\$25.00 material fee required for this course at registration.

W 0628302	9:00-12:10pm	S	Monroe J	SAC C-106	Full Semester
W AND	1:00-4:10pm	S	Monroe J	SAC C-106	

ART 284, INTRODUCTION TO STONE SETTING-JEWELRY**2 UNITS**

Course is an introduction to basic jewelry hand skills, including sawing, filing, soldering, and some fabrication. Emphasis is on cabochon and tube stone setting. Students supply their own stones and metal. May be repeated.

0628401	6:00-10:15pm	W	Monroe J	SAC C-106	Full Semester
---------	--------------	---	----------	-----------	---------------

ART 296, COMPUTER GRAPHICS PRODUCTION**1.5 UNITS**

Computer graphics production for print, film, and video. Advanced study with individual and group projects using PC based 3D modeling and animation system. May be repeated. Prerequisite: Art 196A and 196B, or Telecommunications 181 and 182.

0629604	6:00-10:15pm	T	Waterman P	SAC A-223	4/14-6/2
AND	5 Hrs Arr		Waterman P	SAC A-223	
0629605	6:00-10:15pm	T	Waterman P	SAC A-223	2/11-3/31
AND	5 Hrs Arr		Waterman P	SAC A-223	
0629601	6:00-10:15pm	Th	Waterman P	SAC A-217	2/13-4/2
AND	5 Hrs Arr		Waterman P	SAC A-217	
0629603	6:00-10:15pm	Th	Waterman P	SAC A-217	4/16-6/4
AND	6 Hrs Arr		Waterman P	SAC A-217	

ASTRONOMY

ASTRONOMY 109, INTRODUCTION TO THE SOLAR SYSTEM**3 UNITS**

Surveys history of astronomy, recent discoveries in the solar system, theories for the origin, development of its objects, and future explorations.

0710906	7:30am-8:55	TTh	Mayo W	SAC R-318	Full Semester
0710905	9:00-12:10pm	TWThF	Eastmond T	SAC R-124	1/8-2/1
0710902	7:00-10:10pm	W	Gill R	SAC R-128	Full Semester

ASTRONOMY 110, INTRODUCTION TO STARS AND GALAXIES**3 UNITS**

Surveys recent research about the sun and other stars, exploding stars and black holes, the Milky Way galaxy, other galaxies, and the big bang theory.

0711002	11:00-12:25pm	MW	Eastmond T	SAC R-128	Full Semester
0711004	1:00-2:25pm	TTh	Kalko J	SAC R-124	Full Semester
0711003	1:00-4:10pm	W	Kalko J	SAC R-318	Full Semester

ASTRONOMY 140, ASTRONOMY LABORATORY**1 UNIT**

Techniques of naked eye, binocular and small telescope observation, timekeeping, and practice in astrophotography with small telescopes and field trips to dark sky areas. Prerequisite: Astronomy 109, 110, 110H, or 150 or concurrent enrollment.

0714005	1:15-4:25pm	T	Budarz T	SAC R-328	Full Semester
---------	-------------	---	----------	-----------	---------------

AUTOMOTIVE TECHNOLOGY

AUTOMOTIVE TECHNOLOGY 002, ESSENTIALS**3 UNITS**

Intended for automotive majors. For introduction to basic practical applications of technology required for advanced-level courses. Theory, parts nomenclature, and description of systems are emphasized.

0800201	9:00-12:10pm	F	Wilkes D	SAC Z-103	Full Semester
0800202	5:00-6:25pm	MW	Maine R	SAC Z-103	Full Semester
W 0800203	6:00-9:10pm	F	Stockwell H	SAC Z-103	Full Semester

AUTOMOTIVE TECHNOLOGY 006, AUTOMOTIVE MAINTENANCE**4 UNITS**

Introduction to basic maintenance procedures in the areas of engines, drive lines, and electrical systems. This course is recommended for consumers and students interested in entering the automotive repair field.

0800601	12:30-3:55pm	TTh	Wilkes D	SAC Z-103	Full Semester
---------	--------------	-----	----------	-----------	---------------

AUTOMOTIVE TECHNOLOGY 008, OXYACETYLENE-ARC WELDING**3 UNITS**

Technical knowledge and basic skills needed for occupational oxyacetylene and arc welding processes and applications. Students must furnish safety equipment. (Same as Diesel 008 and Welding 008.)

\$25.00 material fee required for this course at registration.

0800802	8:00-11:10	TTh	Moreno G	SAC K-101	Full Semester
0800804	6:00-9:10pm	MW	Moreno G	SAC K-101	Full Semester
0800803	6:00-9:10pm	TTh	Moreno G	SAC K-101	Full Semester

TKT#	TIME	DAYS	INSTRUCTOR	LOC./RM.	DATES
------	------	------	------------	----------	-------

AUTOMOTIVE TECHNOLOGY 022, ELECTRONICS FUNDAMENTALS**5 UNITS**

Principles and operation of motor vehicle electrical circuits. Emphasis is placed on circuit experiments and use of test equipment and electronic components. Suggested preparation: Automotive Technology 002 or 006. (Same as Diesel 022.)

0802201	6:30-10:35pm	MW	Hammonds E	SAC J-102	Full Semester
---------	--------------	----	------------	-----------	---------------

AUTOMOTIVE TECHNOLOGY 032, TUNE-UP**5 UNITS**

Tune-up procedures including ignition, carburetion, oscilloscope, emission control and computer systems. Students furnish hand tools and safety equipment. Suggested preparation: Automotive Technology 002 or 006.

0803201	8:00-12:05pm	MW	Wilkes D	SAC J-102	Full Semester
---------	--------------	----	----------	-----------	---------------

AUTOMOTIVE TECHNOLOGY 043, AUTOMATIC TRANSMISSION SERVICE**4 UNITS**

Theory, operation, diagnosis, and service procedures of automatic transmissions will be presented. Students furnish hand tools and safety equipment. Suggested preparation: Automotive Technology 002 or 006.

0804301	6:30-10:35pm	TTh	Bullard D	SAC Z-103	Full Semester
---------	--------------	-----	-----------	-----------	---------------

AUTOMOTIVE TECHNOLOGY 053, BRAKES**4 UNITS**

Theory of operation, diagnosis and service of drum, disc, and anti-lock braking systems. Students must furnish hand tools and safety equipment. Suggested preparation: Automotive Technology 002 or 006.

0805301	6:30-10:35pm	MW	Manning J	SAC Z-103	Full Semester
---------	--------------	----	-----------	-----------	---------------

AUTOMOTIVE TECHNOLOGY 054, FRONT ENDS**4 UNITS**

Designed to instruct the student in the operation and services of the following: steering, suspension systems, and wheel alignment procedures. Suggested preparation: Automotive Technology 002 or 006.

0805401	8:00-12:05pm	TTh	Manning J	SAC Z-103	Full Semester
---------	--------------	-----	-----------	-----------	---------------

AUTOMOTIVE TECHNOLOGY 076, ENGINE MACHINING**4 UNITS**

Engine rebuilding and machining practices. Students furnish hand tools and safety equipment. (Same as Diesel 076.) Suggested preparation: Automotive Technology 002 or 006.

0807601	6:30-10:35pm	TTh	Hammonds E	SAC J-102	Full Semester
---------	--------------	-----	------------	-----------	---------------

AUTOMOTIVE TECHNOLOGY 080, COMPUTER CONTROLS**3 UNITS**

Theory, component function, and diagnosis of the following automotive computer controlled systems: G.M.'s, TBI, and PFI; Ford's EEC IV and V; and OBI. Suggested preparation: Automotive Technology 002 or 006 and 032 or one year tune-up related trade experience. May be repeated.

0808001	5:00-6:25pm	MW	Hammonds E	SAC J-102	Full Semester
---------	-------------	----	------------	-----------	---------------

AUTOMOTIVE TECHNOLOGY 081, FUEL INJECTION SYSTEMS**3 UNITS**

Covers current automotive gasoline fuel injection systems, including applications, functions of components, operation and diagnosis. Suggested preparation: Automotive Technology 002 or 006 and 032 or one year tune-up related trade experience. May be repeated.

0808101	5:00-6:25pm	TTh	Wilkes D	SAC J-102	Full Semester
---------	-------------	-----	----------	-----------	---------------

AUTOMOTIVE TECHNOLOGY 082, AUTOMOTIVE COMPUTER SENSORS**3 UNITS**

This course covers the function and testing of computerized engine sensors used on modern vehicles. The use of meters and test equipment will be emphasized. Suggested preparation: Automotive Technology 022, 032, or one year experience in automotive tune-up. May be repeated.

0808201	6:00-10:15pm	TWTh	Hammonds E	SAC J-102	1/8-1/31
---------	--------------	------	------------	-----------	----------

AUTOMOTIVE TECHNOLOGY 085, SMOG CHECK PREPARATION**5 UNITS**

Bureau of Repair recognized Clean Air Car Course. Qualifies the student to take Smog Check examination. Prerequisite: Minimum of 9 semester units of automotive tune-up/electrical course work or 1 year of verifiable automotive tune-up electrical trade experience.

W 0808501	5:30-10:50pm	F	Wilkes D	SAC J-102	Full Semester
-----------	--------------	---	----------	-----------	---------------

AUTOMOTIVE TECHNOLOGY 095, AUTOMOTIVE LAB EXPERIENCE**0.5-4 UNITS**

Lab experience in advanced auto courses. Students furnish hand tools and safety equipment. (Same as Diesel 095.) Open entry/open exit. Grade: CR/NCR only. Prerequisite: Completion of corresponding Automotive Technology course with a grade of C or better.

0809501	12 Hrs Arr		Hammonds E	SAC J-102	Full Semester
0809502	12 Hrs Arr		Bullard D	SAC Z-103	Full Semester
0809503	12 Hrs Arr		Wilkes D	SAC J-102	Full Semester
0809504	12 Hrs Arr		Manning J	SAC Z-103	Full Semester

AUTOMOTIVE TECHNOLOGY 098, L-1 ALTERNATIVE COURSE**2 UNITS**

This course is a Bureau of Automotive Repair certified course. It is designed to prepare the student to pass the L-1 Alternative Course exam. May be repeated. Grade: CR/NCR only. Prerequisite: Automotive Technology 098, A-6 Alternative Course and 098, A-8 Alternative Course.

0809801	6:00-10:15pm	TTh	Wilkes D	SAC Z-103	1/8-1/31
---------	--------------	-----	----------	-----------	----------

BANKING

BANKING 010, TELLER TRAINING FOR FINANCIAL INSTITUTIONS**2 UNITS**

Course provides prospective bank employees with a broad overview of financial institutions and basic knowledge of teller techniques including bank transactions and customer service.

W 0901001	9:00-1:50pm	S	Trabant T	SAC A-207	2/16-3/29
W 0901002	9:00-2:50pm	S	Trabant T	SAC A-207	4/19-5/24

STUDENTS: Web access to student records and registration is on its way!
Go to www.sac.edu – click on online records and update your student profile with your personal email address. **We'll be in touch.**

TKT#	TIME	DAYS	INSTRUCTOR	LOC./RM.	DATES
------	------	------	------------	----------	-------

BIOLOGY

SEE ALSO INTERDISCIPLINARY STUDIES 155, HUMAN SEXUALITY

Attending the first laboratory meeting is MANDATORY. Students who do not attend the first lab meeting will be dropped from the class.

BIOLOGY 054, LANGUAGE OF BIOTECHNOLOGY 3 UNITS

Introduction to basic biotechnology terminology stressing the importance of writing, verbal communication, and reading comprehension. Prepares students for success in college level science courses. (Same as English 054.) Prerequisite: Concurrent enrollment in Biology 055 and Biology 056 is required.

1005401	1:30-2:55pm	MW	Sosta R	SAC R-113	Full Semester
---------	-------------	----	---------	-----------	---------------

(MANDATORY: Concurrent enrollment in Biology 055 Tckt No 1005501 and Biology 056 Tckt No 1005601 required)

BIOLOGY 055, INTRODUCTION TO BIOTECHNOLOGY 2 UNITS

Introduction to the basic concepts and technical skills needed to work in a modern laboratory. Prepares students for success in college level science courses. Prerequisite: Concurrent enrollment in Biology 054 and Biology 056 is required.

1005501	12:00-4:10pm	F	Takahashi M	SAC R-226	Full Semester
---------	--------------	---	-------------	-----------	---------------

(MANDATORY: Concurrent enrollment in Biology 054 Tckt No 1005401 and Biology 056 Tckt No 1005601 required)

BIOLOGY 056, MATH FOR BIOTECHNOLOGY 3 UNITS

Introduction to mathematical concepts used in biotechnology. Prepares students for success in college level courses. Prerequisite: Concurrent enrollment in Biology 054 and Biology 055 is required.

1005601	3:30-4:55pm	MW	Sci Staff	SAC R-113	Full Semester
---------	-------------	----	-----------	-----------	---------------

(MANDATORY: Concurrent enrollment in Biology 054 Tckt No 1005401 and Biology 055 Tckt No 1005501 required)

BIOLOGY 109, FUNDAMENTALS OF BIOLOGY 3 UNITS

Principles of biology stressing the relationship of all organisms from an anatomical, physiological and ecological point of view. Not open to students who are enrolled in or have credit in Biology 159. Concurrent enrollment in Biology 109L recommended.

1010914	Hrs Arr		Priest M	SAC WEB	Full Semester
---------	---------	--	----------	---------	---------------

(See Online Courses page in class schedule or go to www.sac.edu/disted for more information.)

1010915	Hrs Arr		Rourke M	SAC WEB	Full Semester
---------	---------	--	----------	---------	---------------

(See Online Courses page in class schedule or go to www.sac.edu/disted for more information.)

1010901	8:00-9:25	MW	Harper D	SAC R-124	Full Semester
1010916	8:00-11:10	M	Boyd D	SAC R-219	Full Semester
AND	8:00-11:10	W	Boyd D	SAC R-219	Full Semester

(Tckt No 1010916 will emphasize Biology for elementary school teachers. Includes lab)

1010999	8:00-11:10	MTWTh	Harper D	SAC R-128	1/7-1/31
1010912	9:00-12:10pm	S	Grewall M	SAC R-128	Full Semester
1010902	9:30-10:55	MW	Goldmann D	SAC R-128	Full Semester
1010904	12:15-3:25pm	F	Priest M	SAC R-124	Full Semester
1010909	1:00-2:25pm	TTh	Allen R	SAC R-128	Full Semester
1010906	7:00-10:10pm	M	Goldmann D	SAC R-124	Full Semester
1010911	Hrs Arr		Rourke M	SAC WEB	Full Semester

(See Online Courses page in class schedule or to www.sac.edu/disted for more information.)

Attending the first laboratory meeting is MANDATORY. Students who do not attend the first lab meeting will be dropped from the class.

BIOLOGY 109L, FUNDAMENTALS OF BIOLOGY LABORATORY 1 UNIT

Lab experiments to identify and illustrate organisms and their structures. Emphasis is on the relationship of all organisms from an anatomical, physiological and ecological framework. Content correlates to Biology 109 or 159 lecture material. Prerequisite: Biology 109 or 159 or concurrent enrollment.

1010960	8:00-11:10	W	Boyd D	SAC R-219	Full Semester
1010971	8:00-11:10	F	Karimi S	SAC R-202	Full Semester
1010978	8:30-11:40	F	Boyd D	SAC R-228	Full Semester
1010980	9:00-12:10pm	F	Priest M	SAC R-219	Full Semester
1010955	10:00-1:10pm	T	Staff	SAC R-202	Full Semester
1010951	11:00-2:10pm	M	Lopez J	SAC R-202	Full Semester
1010930	11:00-2:10pm	W	Staff	SAC R-202	Full Semester
1010975	12:30-3:40pm	S	Grewall M	SAC R-202	Full Semester
1010962	2:15-5:25pm	W	Sharar E	SAC R-202	Full Semester
1010953	2:30-5:40pm	M	Sharar E	SAC R-202	Full Semester
1010957	3:00-6:10pm	T	Patel D	SAC R-202	Full Semester
1010968	3:30-6:40pm	Th	Staff	SAC R-202	Full Semester
1010972	3:30-6:40pm	F	Priest M	SAC R-202	Full Semester
1010997	6:00-9:10pm	MTWTh	Sharar E	SAC R-202	1/7-1/31
1010961	7:00-10:10pm	T	Beazell J	SAC R-202	Full Semester
1010966	7:00-10:10pm	W	Morales D	SAC R-202	Full Semester
1010969	7:00-10:10pm	Th	Sci Staff	SAC R-202	Full Semester

TKT#	TIME	DAYS	INSTRUCTOR	LOC./RM.	DATES
------	------	------	------------	----------	-------

Bridges to Biotechnology



Are you prepared for the exciting careers in Biotech?

Bio 098 11 Language of Biotechnology
Bio 098 12 Intro to Biotechnology
Bio 098 13 Math for Biotechnology

We will get you up to speed for the new Biotech courses coming to SAC.

www.sac.edu/biotech/

BIOLOGY 128, NATURAL HISTORY OF THE CALIFORNIA COAST 1 UNIT

An ecological study of plant and animal life of the southern and central California coast. May be repeated.

1012801	6:00-7:10pm	Th	Allen R	SAC R-228	2/11-4/11
---------	-------------	----	---------	-----------	-----------

(Pre-trip mtg. Wed, Mar 19, 6-7:10pm, SAC R-228; Field trip Fri, Mar 28 through Sun, Mar 30. Post-trip mtg. Wed, Apr 2, 6-7:10pm, SAC R-228. Tckt 1012801 meets at Caspers Wilderness Park.)

BIOLOGY 139, HEALTH MICROBIOLOGY 4 UNITS

Practical and theoretical aspects of medical microbiology with emphasis on infectious diseases. Designed for allied health majors. Prior completion of Biology 109 or 149 recommended.

\$15.00 material fee required for this course at registration.

1013901	5:30-6:55pm	TTh	Staff	SAC R-128	Full Semester
AND	3:00-5:05pm	TTh	Staff	SAC R-226	Full Semester
1013902	5:30-6:55pm	TTh	Staff	SAC R-128	Full Semester
AND	7:20-9:25pm	TTh	Humphries V	SAC R-226	Full Semester
1013903	5:30-6:55pm	TTh	Staff	SAC R-128	Full Semester
AND	12:30-2:35pm	TTh	Staff	SAC R-226	Full Semester

BIOLOGY 149, HUMAN ANATOMY AND PHYSIOLOGY 4 UNITS

Normal structure and function of the human body. Designed for allied health science majors. May not meet requirements for physical education or BSN majors.

1014901	6:00-9:10pm	T	Cast S	SAC R-124	Full Semester
AND	9:00-12:10pm	Th	Hampton J	SAC R-201	Full Semester
1014902	6:00-9:10pm	T	Cast S	SAC R-124	Full Semester
AND	1:00-4:10pm	Th	Cast S	SAC R-201	Full Semester
1014903	6:00-9:10pm	T	Cast S	SAC R-124	Full Semester
AND	7:00-10:10pm	Th	Cast S	SAC R-201	Full Semester

BIOLOGY 179, PLANTS OF ORANGE COUNTY 2 UNITS

Identification and study of ornamental and wild plants in Orange County. Field trips are a major part of the course.

1017901	8:00-12:00pm	S	Allen R	SAC R-228	Full Semester
---------	--------------	---	---------	-----------	---------------

(Tckt 1017901 meets Saturdays: Feb 16, 23, Mar 15, 22, Apr 19, 26, May 17, 31 and Jun 7. This is a field course that requires hiking.)

BIOLOGY 200, ENVIRONMENT OF MAN 3 UNITS

Study of current problems such as energy, food, resources, population, and land use, including economic and political factors. Class discussion, films, demonstrations, field trips. A natural science elective. (Same as Environmental Studies 200 and Science 200).

1020001	7:00-10:10pm	T	Chlup I	SAC R-228	Full Semester
---------	--------------	---	---------	-----------	---------------

BIOLOGY 211, CELLULAR AND MOLECULAR BIOLOGY 5 UNITS

An investigation of the cellular and molecular basis of life stressing: cell structure and function, energy and information flow, cellular reproduction, genetics, the molecular basis of inheritance, and cell evolution. This course is a prerequisite for Biology 212 and Biology 214. Prior completion of Chemistry 119 or 209 or equivalent recommended. Prerequisite: Mathematics 080 with a grade of C or better.

1021104	8:00-9:25	TTh	Lui A	SAC R-124	Full Semester
AND	9:30-12:40pm	TTh	Lui A	SAC R-219	Full Semester
1021103	4:30-5:55pm	TTh	Lopez J	SAC R-124	Full Semester
AND	6:15-9:25pm	TTh	Lopez J	SAC R-219	Full Semester

ALL BIOLOGY CLASSES FIRST CLASS MEETING

Students who do not attend the FIRST LABORATORY session may be DROPPED from the roll sheet. A new lab manual is required for the first laboratory session.

TKT#	TIME	DAYS	INSTRUCTOR	LOC./RM.	DATES
------	------	------	------------	----------	-------

BIOLOGY 212, ANIMAL DIVERSITY AND ECOLOGY 5 UNITS

Study of ecological principles, and relationships between animal diversity and ecosystems. Habitat, population, and ecological interactions are stressed in a survey of the major animal taxa that addresses structure, function, behavior and adaptation. Prerequisite: Biology 211 with a grade of C or better.

1021202	5:00-6:25pm	MW	Allen R	SAC R-228	Full Semester
AND	7:00-10:10pm	MW	Allen R	SAC R-228	

(Biology 212 is replacing Biology 203)

BIOLOGY 214, PLANT DIVERSITY AND EVOLUTION 5 UNITS

Principles and processes of evolution leading to biodiversity. Survey of the organisms, viruses, prokaryotes, fungi, algae, and plants with emphasis on evolutionary adaptations of the anatomy, physiology, and life cycles of these organisms. Field trips required. Prerequisite: Biology 211 with a grade of C or better.

1021402	12:00-1:25pm	MW	Harper D	SAC R-219	Full Semester
AND	1:30-4:40pm	MW	Harper D	SAC R-219	

(Biology 214 is replacing Biology 205)

BIOLOGY 217, PATHOPHYSIOLOGY 2 UNITS

Dynamic aspects of human diseases with emphasis on clinical practice. Prerequisite: Biology 149, 239 or 249.

1021702	Hrs Arr		Hampton J	SAC WEB	1/7-1/31
---------	---------	--	-----------	---------	----------

(This is a hybrid in-class and online course. All campus mtgs are mandatory. On-campus mtgs: Mon., Jan 7, 14, 21 and Thurs., Jan 31 (Final exam), 10:30am-12:30pm, SAC W-101. Students must have Microsoft Word, Powerpoint, and Adobe Acrobat for this course. See Online Courses page in class schedule or go to www.sac.edu/disted for more information.)

1021701	Hrs Arr		Hampton J	SAC WEB	Full Semester
---------	---------	--	-----------	---------	---------------

(This is a hybrid in-class and online course. All campus mtgs are mandatory. On-campus mtgs: Feb 6, 27, Mar 20, Apr 17, May 8, 29 (Final exam), 6-8pm, SAC R-303-1. See Online Courses page in class schedule or go to www.sac.edu/disted for more information.)

BIOLOGY 229, GENERAL MICROBIOLOGY 5 UNITS

Study of bacteria, protozoa, fungi, algae and viruses, including techniques of handling microbes. Designed for biology, pre-nursing (BSN), and preprofessional majors. Prerequisite: Biology 109/109H and 109L, or 139, or 149, or 211 or Chemistry 119 or 209.

\$20.00 material fee required for this course at registration.

1022901	1:00-2:25pm	MW	Sci Staff	SAC R-128	Full Semester
AND	3:00-6:10pm	MW	Sci Staff	SAC R-226	
1022904	1:00-2:25pm	MW	Sci Staff	SAC R-128	Full Semester
AND	9:00-12:10pm	MW	Morales D	SAC R-226	
1022905	1:00-2:25pm	MW	Sci Staff	SAC R-128	Full Semester
AND	6:30-9:40pm	MW	Sci Staff	SAC R-226	

BIOLOGY 239, GENERAL HUMAN ANATOMY 4 UNITS

Structure of the human body. Systems, organs, and tissues are studied from human skeletons, models, charts, slides and CD-ROM programs. Laboratory includes dissection of a cat, and periodic demonstrations on a prosected cadaver as available.

1023950	Hrs Arr		Mansfield P	SAC WEB	Full Semester
AND	6:30-9:40pm	F	Johnson R	SAC R-201	

(Complete online orientation exercises: http://ext.sac.edu/faculty_staff/mansfield_patricia. See Online Courses page in class schedule or go to www.sac.edu/disted for more information.)

1023909	8:30-11:40	S	Sci Staff	SAC R-113	Full Semester
AND	12:30-3:40pm	S	Sci Staff	SAC R-113	
1023901	10:00-11:25	MW	Hampton J	SAC R-124	Full Semester
AND	1:00-4:10pm	M	Hampton J	SAC R-201	
1023902	10:00-11:25	MW	Hampton J	SAC R-124	Full Semester
AND	4:30-7:40pm	M	Sci Staff	SAC R-201	
1023904	10:00-11:25	MW	Hampton J	SAC R-124	Full Semester
AND	9:00-12:10pm	T	Patel D	SAC R-201	
1023907	10:00-11:25	MW	Hampton J	SAC R-124	Full Semester
AND	1:00-4:10pm	T	Hampton J	SAC R-201	
1023908	10:00-11:25	MW	Hampton J	SAC R-124	Full Semester
AND	9:00-12:10pm	F	Johnson R	SAC R-201	

(Tckt No 1023908 will specifically utilize cadaver demonstration/dissection instead of cats)

1023951	Hrs Arr		Mansfield P	SAC WEB	Full Semester
AND	3:00-6:10pm	F	Johnson R	SAC R-201	

(Complete online orientation exercises: http://ext.sac.edu/faculty_staff/mansfield_patricia. See Online Courses page in class schedule or go to www.sac.edu/disted for more information. Tckt No 1023951 will specifically utilize cadaver demonstration/dissection instead of cats.)

BIOLOGY 249, HUMAN PHYSIOLOGY 4 UNITS

Microscopic, macroscopic and dynamic view of the human physiological processes. The lecture portion includes a thorough consideration of both "cell and systems" physiology. Lab work includes the use of techniques used in basic research, an introduction to the use of standard medical equipment and the performance of medical lab tests. Non-invasive experiments are performed on students enrolled in the class. Prerequisite: Biology 239.

1024901	1:15-4:25pm	M	Mansfield P	SAC R-124	Full Semester
AND	1:00-4:10pm	W	Backey J	SAC R-201	
1024902	1:15-4:25pm	M	Mansfield P	SAC R-124	Full Semester
AND	9:00-12:10pm	W	Sci Staff	SAC R-201	

TKT#	TIME	DAYS	INSTRUCTOR	LOC./RM.	DATES
------	------	------	------------	----------	-------

1024950	Hrs Arr		Mansfield P	SAC WEB	Full Semester
AND	5:00-8:10pm	W	Backey J	SAC R-201	

(Complete online orientation exercises: http://ext.sac.edu/faculty_staff/mansfield_patricia. See Online Courses page in class schedule or go to www.sac.edu/disted for more information.)

1024951	Hrs Arr		Mansfield P	SAC WEB	Full Semester
AND	5:00-8:10pm	T	Mansfield P	SAC R-201	

(Complete online orientation exercises: http://ext.sac.edu/faculty_staff/mansfield_patricia. See Online Courses page in class schedule or go to www.sac.edu/disted for more information.)

BLACK STUDIES

SEE ALSO ETHNIC STUDIES

BLACK STUDIES 101, INTRODUCTION TO BLACK STUDIES 3 UNITS

Examines the contributions of Black Americans to the history of America in the areas of history, literature, the arts, science, and technology. In relationship to historical periods, social, ethnic, and cultural environments will be explored to assess their impact on these contributions.

9720101	7:00-10:10pm	T	Riggins C	SAC B-31	Full Semester
---------	--------------	---	-----------	----------	---------------

BUSINESS

BUSINESS 080, BUSINESS MATHEMATICS 3 UNITS

Business math applications including review of fractions, decimals, percents, banking, discounts, markups, payroll, interest calculation, installment buying, mortgages, depreciation, taxes, insurance, stocks, bonds, and mutual funds.

1108001	7:00-10:10pm	Th	Singer D	SAC A-222	Full Semester
---------	--------------	----	----------	-----------	---------------

BUSINESS 100, FUNDAMENTALS OF BUSINESS 3 UNITS

An introduction to the basic fundamentals of business. A survey of marketing, management, production, accounting, finance, and economics and how they interrelate in the business environment.

1110007	9:45-11:10	TTh	Grant M	SAC A-130	Full Semester
1110002	11:30-12:55pm	MW	Manzano F	SAC A-205	Full Semester
1110011	11:30-12:55pm	TTh	Doolittle Jr G	SAC A-208	Full Semester
1110009	1:00-3:10pm	S	Rangel S	SAC A-210	2/23-6/8
1110003	7:00-10:10pm	M	Kishel G	SAC A-207	Full Semester
1110008	7:00-10:10pm	T	Woolgar D	SAC D-102	Full Semester
1110010	Hrs Arr		Grant M	SAC WEB	Full Semester

(Orientation Wed, Feb 13, 5-6:30pm, SAC A-108. See Online Courses page in class schedule or go to www.sac.edu/disted for more information.))

BUSINESS 101, BUSINESS LAW 3 UNITS

Legal fundamentals important in commerce and personal business transactions. Includes a study of types of law, the courts, torts, contracts, sales, and commercial paper.

1110102	7:00-10:10pm	M	Mallory C	SAC B-17	Full Semester
---------	--------------	---	-----------	----------	---------------

BUSINESS 103, COOPERATIVE WORK EXPERIENCE EDUCATION-OCCUPATIONAL 1-4 UNITS

Supervised paid or volunteer experience in student's major including new or expanded responsibilities. Must enroll in 7 units. Limit 16 units in occupational cooperative education courses. Students must attend ONE orientation meeting. Open entry/open exit. May be repeated. Grade: CR/NCR only.

1110301	Hrs Arr		Gillis J	SAC A-104	Full Semester
---------	---------	--	----------	-----------	---------------

(Orientation Wed, Feb 13, 12:30-1:25pm, or 6-6:50pm, SAC A-104)

BUSINESS 105, LEGAL ENVIRONMENT OF BUSINESS (CAN BUS 12) 3 UNITS

A study of the courts, torts (including product liability), crimes, contracts, employment, partnerships, corporations, government regulation, and international law.

1110508	8:00-9:25	TTh	Doolittle Jr G	SAC A-207	Full Semester
1110503	9:00-12:10pm	S	Staff	SAC A-130	Full Semester
1110507	9:45-11:10	MW	Manzano F	SAC A-205	Full Semester
1110509	5:30-8:35pm	MW	Lamarra K	SAC B-16	2/11-4/2
1110504	7:00-10:10pm	W	Mills L	SAC D-103	Full Semester
1110505	7:00-10:10pm	Th	Mills L	SAC A-130	Full Semester

Earn a Business Administration Degree on Saturdays by taking the following Business courses:



0110102	Accounting 101	8:00-12:15pm
0110210	Accounting 102	8:00-12:15pm
1110009	Bus 100 – Fundamentals of Business	9:00-12:10pm
1110503	Bus 105 – Legal Environment of Business	9:00-12:10pm
1122202	Bus 222 – Business Communications	9:00-12:10pm

Saturday classes also available in Paralegal, Business Applications

New Courses in Business



0110104	ACCT 101 – Financial Accounting Hybrid
	ACCT 035 – QuickBooks (In class/online)
1112702	BUS 127 – Intro. to E-Commerce
1209801	BA 098 – What's New in Office 2007
1219801	BA 198 – Intro. to Geographic Info. Systems (GIS)
1219803	BA 198 – Desktop Computer Security
1219802	BA 198 – PDA Training
1719802	CS 198 – Windows Vista Operating System
1716901	CS 169 – SQL Server
3211201	ENGR 112 – Society and the Built Environment
3220501	ENGR 205 – Civil Digital Computations
6013502	MNGT 135 – Human Resource Management

Paralegal program has a new Fast Track program

BUSINESS 106, CULTURE AND INTERNATIONAL BUSINESS-KISS, BOW, OR SHAKE HANDS

3 UNITS

An introduction to different culture's values and beliefs and how those values and beliefs affect international business interactions. Analysis of cross-cultural attitudes towards management, business strategies, business relationships, negotiation, status, rules and motivation when working and communicating in international business.

1110602	1:15-2:40pm	TTh	Grant M	SAC A-203	Full Semester
1110601	7:00-10:10pm	W	Doolittle Jr G	SAC A-203	Full Semester

BUSINESS 120, PRINCIPLES OF MANAGEMENT

3 UNITS

Principles, methods, and procedures essential to the successful management of human and financial resources. Planning, organizing, directing, controlling. (Same as Management 120.)

1112005	11:30-12:55pm	TTh	Howe J	SAC A-207	Full Semester
1112007	7:00-10:10pm	W	Howe J	SAC A-130	Full Semester

BUSINESS 121, HUMAN RELATIONS & ORGANIZATIONAL BEHAVIOR

3 UNITS

The role of the manager and management's relationship to employees. Includes the application of motivational theories, communications, leadership, and organizational structure. (Same as Management 121.)

1112102	7:00-10:10pm	T	Irion M	SAC D-103	Full Semester
---------	--------------	---	---------	-----------	---------------

BUSINESS 127, INTRODUCTION TO E-COMMERCE

3 UNITS

Electronic commerce from a managerial perspective focusing on the retailing, business-to-business and service industries. Topics include: e-commerce infrastructure, intranets and extranets, electronic payment systems, marketing research, advertising, e-commerce strategies, and privacy issues.

1112701	7:00-10:05pm	Th	Sabetiashraf R	DMC-203	Full Semester
---------	--------------	----	----------------	---------	---------------

BUSINESS 130, PERSONAL FINANCE

3 UNITS

Various aspects of personal financial planning covering family budgeting, investments, housing, insurance, taxation, estate planning, credit and its uses, planning for retirement, installment buying.

1113003	6:00-9:10pm	T	Koenig R	SAC A-209	Full Semester
1113005	Hrs Arr		Koenig R	SAC WEB	Full Semester

(Orientation Mon, Feb 11, 7pm or Tues. Feb 12, 3:30pm, SAC A-104. See Online Courses page in class schedule or go to www.sac.edu/disted for more information.

Email instructor first week of class.)

1113008	Hrs Arr		Mitchell E	SAC WEB	1/7-2/6
---------	---------	--	------------	---------	---------

(Orientation Mon, Jan 7, 6pm, SAC A-104. See Online Courses page in class schedule or go to www.sac.edu/disted for more information. Email instructor first week of class.)



All students in Business and Computer classes are eligible to use our well-equipped **BUSINESS COMPUTER LABS** in Rooms A-104 and A-108. Open six days a week to meet your computing needs.

BUSINESS 140, PRINCIPLES OF FINANCE

3 UNITS

An introduction to corporate financial management, and the functioning of global financial markets. Includes financial planning and analysis, working capital management, capital budgeting, time value of money, risk analysis, capital markets and long term financing.

1114002	Hrs Arr		Mitchell E	SAC WEB	1/7-2/2
---------	---------	--	------------	---------	---------

(Orientation Mon, Jan 7, 6pm, SAC A-104. See Online Courses page in class schedule or go to www.sac.edu/disted for more information. Email instructor first week of class.)

BUSINESS 141, THE GLOBALIZATION OF MARKETING

1 UNIT

Learn how to adapt marketing techniques to international markets, how to develop marketing strategies, and how to target markets based on the cultural, political and economic environments. Learn how to create forecasts and budgets for international markets.

1114101	6:00-10:05pm	T	Grant M	SAC A-203	2/12-3/4
---------	--------------	---	---------	-----------	----------

BUSINESS 142, INTERNATIONAL MARKET RESEARCH AND PLANNING

1 UNIT

How to research international markets for opportunities using the Internet, government and private resources as well as in-market surveys. Includes the development of international marketing strategies and the analysis of domestic and international markets for import and export opportunities

1114201	6:00-10:05pm	T	Staff	SAC A-203	3/11-4/1
---------	--------------	---	-------	-----------	----------

BUSINESS 143, PACKAGING, PRICING, AND PROMOTING PRODUCTS/SERVICES FOR EXPORT

1 UNIT

Learn to adapt products and services for export to international markets. Implement exciting advertising plans. Develop competitive price structures to entice international customers to buy your products.

1114301	6:00-10:05pm	T	Grant M	SAC A-203	4/15-5/6
---------	--------------	---	---------	-----------	----------

BUSINESS 145, CHANNELS OF DISTRIBUTION IN INTERNATIONAL MARKETS

1 UNIT

Learn alternative methods to distribute different products and services to different countries. Learn to use international distributors and agents. Adopt strategies to maintain product quality, product positioning and competitive price structure.

1114501	6:00-10:05pm	T	Grant M	SAC A-203	5/13-6/3
---------	--------------	---	---------	-----------	----------

BUSINESS 150, INTRODUCTION TO COMPUTING AND APPLICATION SOFTWARE (CAN BUS 6)

4 UNITS

Introduction to computer concepts, computer organization, computer operation, information systems and business problem-solving through the use of application software. (Equivalent to ISDS 265 at California State University, Fullerton.)

\$4.00 material fee required for this course at registration.

(Software Utilized: Excel 2003/Access 2003)

1115020	8:00-10:05	TTh	Kushida C	SAC A-206	Full Semester
---------	------------	-----	-----------	-----------	---------------

1115002	5:30-10:05pm	MW	Beck J	SAC B-16	4/14-6/4
---------	--------------	----	--------	----------	----------

1115005	6:00-8:00pm	T	Takacs P	SAC A-208	Full Semester
---------	-------------	---	----------	-----------	---------------

AND	8:00-10:10pm	T	Takacs P	SAC A-208	
-----	--------------	---	----------	-----------	--

1115004	Hrs Arr		Kushida C	SAC WEB	Full Semester
---------	---------	--	-----------	---------	---------------

(Orientation Tues, Feb 12, 5pm and/or Wed, Feb 13, 11:30am, SAC A-108. See Online Courses page in class schedule or go to www.sac.edu/disted for more information. Email instructor first week of class.)



FINANCIAL PLANNING CONNECTIONS

Many Courses Offered On Line

PERSONAL FINANCE	Business 130 Personal Finance
CORPORATE FINANCE	Business 140 Principles of Finance
INVESTMENTS	Business 160 Introduction to Security Investments
TAXATION	Accounting 104 Federal and California Taxes (Qualify for Tax Preparer's License with this course)
Log on as a guest at: http://disted.sac.edu	

TKT#	TIME	DAYS	INSTRUCTOR	LOC./RM.	DATES
------	------	------	------------	----------	-------

EARN UP TO 16 UNITS OF CREDIT ON YOUR JOB

Cooperative Work Experience

Paid or volunteer supervised employment designed for students who are training on their current worksite for upward mobility or those working on non-paid worksites to acquire entry-level occupational training. If you have any questions, call the Work Experience Coordinator at SAC (714) 564-6763 or (714) 564-6750.

- CSU transferable as electives.
- Must be working in a paid or volunteer position.
- Students must attend one orientation meeting—see below.
- Must be enrolled in 7 units minimum (including work experience units).

ORIENTATION MEETINGS

Attend orientation meetings at the college where enrolled. To complete paperwork, weekly class times are the same as for orientations.

SAC: Wednesday, February 13, 12:30-1:25pm or 6:00-6:50pm, SAC A-104

OCCUPATIONAL WORK EXPERIENCE

Every major enrolls in Business 103

- SAC ticket #1110301

For students who are gaining experience on their current worksite through paid or volunteer employment. These are occupational jobs which relate to the student's major. All questions will be answered and paperwork distributed at orientation meetings. Amount of credit given each semester is 1 unit of credit for 5 hours worked weekly, 2 units of credit for 10 hours worked weekly, 3 units of credit for 15 hours worked weekly, and 4 units of credit for 20 hours worked weekly throughout the semester. Maximum of 4 units of credit each semester. Limit 16 units in Occupational Work Experience courses.

BUSINESS 160, INTRODUCTION TO STOCK AND BOND INVESTMENTS 3 UNITS

An introductory course in investments with emphasis on stocks and bonds, mechanics of investing, options, and financial planning.

1116002 Hrs Arr Ridgeway R SAC WEB Full Semester
(Orientation Tues, Feb 12, 5pm, SAC A-104. See Online Courses page in class schedule or go to www.sac.edu/disted for more information. Email instructor first week of class.)

BUSINESS 163, INTERNATIONAL METHODS OF PAYMENT AND LETTERS OF CREDIT 1 UNIT

Analyze international methods of payment to determine risks and benefits. Learn how to initiate and utilize a letter of credit and its role in international transactions. Learn how to check customer's credit and assign payment terms.

1116301 6:00-10:05pm Th Staff SAC A-203 5/15-6/5

BUSINESS 164, ALTERNATIVE FINANCING TECHNIQUES FOR INTERNATIONAL TRADE 1 UNIT

Explore the alternative financing techniques of bartering, countertrade and forfeiting for medium-term financing. Learn how the foreign exchange market operates and the risk and management techniques of foreign exchange.

1116401 6:00-10:05pm Th Staff SAC A-203 4/17-5/8

BUSINESS 165, INTERNATIONAL TRADE FINANCE AND INSURANCE 1 UNIT

Learn how to borrow money based on a specific import/export transaction. Learn documentary banker's acceptances, borrowing against receivables and factoring. Discover Eximbank. Analyze risks and insure transactions.

1116501 6:00-10:05pm Th Yamada S SAC A-203 3/13-4/3

BUSINESS 166, FINANCING AN IMPORT/EXPORT BUSINESS 1 UNIT

Learn where and how to obtain financing for an international business. Discover domestic and international financing sources, types of financing, lending sources and government finance assistance organizations. Analyze loan documents and assess risks.

1116601 6:00-10:05pm Th Yamada S SAC A-203 2/14-3/6

BUSINESS 170, PRINCIPLES OF SMALL BUSINESS MANAGEMENT 3 UNITS

Practical business skills needed to start and operate a small business. Information on risk management, site location, legal aspects, financing, budgeting, marketing, and management techniques.

1117001 8:00-9:25 MW Thomason G SAC A-205 Full Semester

1117002 7:00-10:10pm W Thomason G SAC D-102 Full Semester

BUSINESS 172, SMALL BUSINESS MARKETING AND ADVERTISING 3 UNITS

Techniques for promoting a small business. Includes preparation of advertisements, customer research, media selection, budgeting and scheduling, and the evaluation of promotional effectiveness. (Same as Marketing 172.)

1117201 7:00-10:10pm T Wilson G SAC A-217 Full Semester

BUSINESS 222, BUSINESS WRITING 3 UNITS

Overview of communication skills used in business; emphasizes guidelines for writing and speaking skills necessary for today's high-tech, international business environment. Prerequisite: English 101 or 101H.

W 1122203 8:00-9:25 MW Lamarra K SAC A-203 Full Semester

1122202 9:00-12:10pm S Hobbs R SAC A-215 Full Semester

1122207 9:45-11:10 TTh Doolittle Jr G SAC A-205 Full Semester

1122205 1:15-2:40pm TTh Woolgar D SAC A-207 Full Semester

1122204 7:00-10:10pm T Harasin L SAC A-130 Full Semester

1122209 7:00-10:10pm Th Woolgar D SAC D-103 Full Semester

TKT#	TIME	DAYS	INSTRUCTOR	LOC./RM.	DATES
------	------	------	------------	----------	-------

BUSINESS SEMINAR (FOR A BUSINESS SEMINAR CLASS SCHEDULE PLEASE CALL (714) 241-5823)

BUSINESS APPLICATIONS

SEE ALSO
COMPUTER SCIENCE

LOOKING FOR COMPUTER KEYBOARDING SKILLS
SEE: BUSINESS APPLICATIONS 110 COMPUTER KEYBOARDING SKILLS
(FORMERLY BUSINESS APPLICATIONS 010)
OR
BUSINESS APPLICATIONS 115 COMPUTER KEYBOARDING SPEED AND
ACCURACY DEVELOPMENT (FORMERLY BUSINESS APPLICATIONS 015)

BUSINESS APPLICATIONS 016, COMPUTER OFFICE MODULES 0.5-6 UNITS

Office training on an individualized basis to include: computer applications, communication skills, office procedures and equipment for entry level office positions, Microsoft Office Specialist practice testing and office simulation. Open entry/open exit. Grade: CR/NCR only.

\$2.00 material fee required for this course at registration.

1201601 9:00-12:10pm M Miller J SAC A-228 Full Semester

AND 9:00-12:10pm W Le N SAC A-228

1201603 9:00-1:10pm MW Nguyen M SAC A-228 1/7-1/30

1201602 6:00-10:10pm Th Banh H SAC A-228 Full Semester

BUSINESS APPLICATIONS 017, BUSINESS WRITING SKILLS 3 UNITS

Comprehensive up-to-date usage of grammar including punctuation, capitalization, number style, spelling, vocabulary development, and other business writing skills. Designed for today's administrative assistant, secretary, and word processor, or other office worker.

1201703 9:00-10:25 TTh Miller J SAC A-222 Full Semester

1201702 7:00-10:10pm M Osgood J SAC A-203 Full Semester

BUSINESS APPLICATIONS 018, OFFICE PROCEDURES 3 UNITS

Develop office skills, procedures, and problem solving techniques to adapt to the electronic office. Includes interpersonal relations, administrative support, office communication, and work management.

1201801 11:00-12:25pm TTh Miller J SAC A-222 Full Semester

BUSINESS APPLICATIONS 034, MACHINE CALCULATION 1.5 UNITS

Instruction in the 10-key by touch system for the calculator and basic business math skills. Students develop skills and concepts for the workplace, gain familiarity with business concepts, and develop speed and accuracy solving typical business math problems.

\$2.00 material fee required for this course at registration.

1203401 2:00-5:05pm T Staff SAC A-228 4/15-6/3

BUSINESS APPLICATIONS 035, COMPUTER BASICS 1.5 UNITS

Introduction to the components of the personal computer and how they are used. Gain knowledge in basic computer operations.

\$2.00 material fee required for this course at registration.

1203501 11:00-12:30pm MW Negrete T SAC A-224 2/11-4/2

1203503 7:00-10:10pm T Singer D SAC A-226 2/12-4/1

BUSINESS APPLICATIONS 036, DATA ENTRY 1.5 UNITS

Instruction in the process of entering alphabetic and numeric data into the computer to produce report formats such as statistical reports, inventories, payroll records and registration forms. Students develop dexterity and accuracy while learning data entry procedures.

\$2.00 material fee required for this course at registration.

W 1203601 6:15-9:35pm F Nguyen T SAC A-228 2/15-4/4

NEW from the Business Applications Department Fast Forward to the Job You Want



Earn a Certificate of Preparation
in one semester!

Entry-level Accounting Clerk option
Entry-level General Office Clerk option
Interview & Job Search Preparation option

BA 016 – COMPUTER OFFICE MODULES
OPEN-ENTRY / OPEN-EXIT 0.5 – 6.0 UNITS
FLEXIBLE HOURS—CREATE YOUR OWN SCHEDULE

Watch for flyers and brochures or call (714) 564-6772

TKT#	TIME	DAYS	INSTRUCTOR	LOC./RM.	DATES
------	------	------	------------	----------	-------

New from the Business Applications Department!

Earn College Credit when you pass a
Microsoft Office Specialist Exam in
Word, Excel, PowerPoint, Access, or Outlook.



Watch for flyers and brochures or call (714) 564-6773

BUSINESS APPLICATIONS 038, TELEPHONE TECHNIQUES 0.5 UNITS

Course will provide a solid foundation for students who want training in the professional use of the telephone. Hands on training in handling business calls.

1203801	1:00-5:05pm	Th	Staff	SAC A-228	4/24-4/29
---------	-------------	----	-------	-----------	-----------

BUSINESS APPLICATIONS 043, MICROSOFT OFFICE SPECIALIST PREPARATION 0.5 UNITS

Prepares students to take the Microsoft Office Specialist certification exams. Students choose practice programs that replicate actual Microsoft Office Specialist exams for Word, Excel, PowerPoint, Access and/or Outlook. May be repeated. Grade: CR/NCR only.

\$2.00 material fee required for this course at registration.

1204301	5:00-6:55pm	M	Staff	SAC A-228	5/12-6/2
---------	-------------	---	-------	-----------	----------

BUSINESS APPLICATIONS 047, INTRODUCTION TO THE LEGAL OFFICE 3 UNITS

Study of the role of law office support personnel. Emphasis on duties: ethics, terminology, interviewing, investigation, court system, research, law office organization.

1204701	8:00-11:10		Manzano F	SAC A-208	2/12-4/3
W 1204703	8:00-5:10pm	S	Staff	SAC A-205	2/23-3/29
1204702	7:00-10:10pm	M	Nelson A	SAC A-205	Full Semester

BUSINESS APPLICATIONS 049, INTRODUCTION TO MICROSOFT ACCESS 1.5 UNITS

Introduction to Microsoft Access - a database program which teaches how to create, design, and use databases.

\$2.00 material fee required for this course at registration.

(Software Utilized: Access 2007)

1204902	7:00-10:15pm	T	Molitor M	SAC B-15	4/15-6/2
---------	--------------	---	-----------	----------	----------

BUSINESS APPLICATIONS 052, INTERNATIONAL OFFICE SKILLS 3 UNITS

International cross-cultural communications skills in the business office context. Emphasis on communicative activities, telephone techniques, customer service, bilingual medical terminology, interpersonal communications, filing, conflict resolution and career planning for international and domestic office occupations.

\$4.00 material fee required for this course at registration.

1205201	7:00-10:10pm	Th	Staff	SAC B-17	Full Semester
---------	--------------	----	-------	----------	---------------

BUSINESS APPLICATIONS 053, SPANISH BILINGUAL INTERPRETING FOR LEGAL, MEDICAL, AND GENERAL OFFICES 3 UNITS

Introductory bilingual legal and medical office terminology in Spanish (oral and written). Simultaneous interpretation of legal and business documents. Composition and grammar in Spanish bilingual office communications. Understanding of Spanish recommended.

1205302	9:30-12:40pm	M	Hernandez M	SAC A-203	Full Semester
---------	--------------	---	-------------	-----------	---------------

BUSINESS APPLICATIONS 054, SPANISH BILINGUAL COMPUTER APPLICATIONS 3 UNITS

Basic introduction to international bilingual computer applications using Microsoft Word, Excel, and other computer applications. Course will include Internet international business format, forms and bilingual vocabulary. Spanish bilingual instruction available.

\$4.00 material fee required for this course at registration.

W 1205401	Hrs Arr		Hernandez M	SAC WEB	Full Semester
-----------	---------	--	-------------	---------	---------------

(Orientation Wed, Feb 13, 6pm and/or Thurs, Feb 14, 2pm, SAC A-108. See Online Courses page in class schedule or go to www.sac.edu/disted for more information. Email instructor first week of class.)

BUSINESS APPLICATIONS 056, GENERAL FOUNDATION FOR BILINGUAL BUSINESS INTERPRETATION-SPANISH/ENGLISH 3 UNITS

A course designed to give general foundations for interpreting and translating in Spanish and English for government and private businesses. Fluency in Spanish and English strongly recommended. May be repeated.

W 1205602	9:00-12:10pm	S	Frias Callejas M	SAC A-222	Full Semester
-----------	--------------	---	------------------	-----------	---------------

BUSINESS APPLICATIONS 057, MEDICAL INTERPRETATION AND TRANSLATION-SPANISH/ENGLISH 3 UNITS

A course in medical interpretation/translation designed for employment certification of interpreters for governmental and private health services-providers. May be repeated. Prerequisite: Business Applications 052.

1205701	9:30-12:40pm	W	Hernandez M	SAC A-203	Full Semester
---------	--------------	---	-------------	-----------	---------------

BUSINESS APPLICATIONS 058, LEGAL INTERPRETATION AND TRANSLATION-SPANISH/ENGLISH 3 UNITS

A course in legal interpretation/translation designed for employment certification of interpreters for government and private legal businesses. May be repeated. Prerequisite: Business Applications 053.

W 1205801	1:00-3:55pm	S	Staff	SAC A-222	Full Semester
-----------	-------------	---	-------	-----------	---------------

BUSINESS APPLICATIONS 066, MICROSOFT OUTLOOK 1.5 UNITS

Instruction in the use of Microsoft Outlook, a personal information management program used to communicate with others. Schedule appointments and tasks, record information about your personal and business contacts, and organize your files.

\$2.00 material fee required for this course at registration.

(Software Utilized: Outlook 2003)

1206602	5:00-6:55pm	M	Lehrer C	SAC A-228	2/11-5/7
---------	-------------	---	----------	-----------	----------

BUSINESS APPLICATIONS 110, COMPUTER KEYBOARDING SKILLS 1-2 UNITS

Proficiency based keyboarding skills includes alphabet and numeric keyboard, speed and accuracy development and basic word processing skills. Open entry/open exit. May be repeated.

\$2.00 material fee required for this course at registration.

1211001	8:00-9:55	MW	Hansen J	SAC A-226	Full Semester
1211002	9:00-1:05pm	TTh	Lehrer C	SAC A-226	1/8-1/31
1211003	9:00-1:10pm	F	Le N	SAC A-226	Full Semester
W 1211008	9:00-1:10pm	S	Banh H	SAC A-226	Full Semester
1211004	10:00-11:55	TTh	Nguyen M	SAC A-226	Full Semester
1211009	10:30-12:30pm	MW	Hansen J	SAC A-226	Full Semester
1211006	6:00-10:10pm	TTh	Nguyen M	SAC A-226	1/8-1/31
1211005	6:00-10:10pm	W	Lehrer C	SAC A-222	Full Semester
W 1211012	Hrs Arr		Hernandez M	SAC WEB	Full Semester

(Orientation Wed, Feb 13, 2pm and/or 6pm, SAC A-108. See Online Courses page in class schedule or go to www.sac.edu/disted for more information. Email instructor first week of class.)

BUSINESS APPLICATIONS 115, COMPUTER KEYBOARDING SPEED AND ACCURACY DEVELOPMENT 1-2 UNITS

Intense review of letter, number, and symbol typing. Emphasis on individual's problem keys. Increase keyboarding speed and improve accuracy through prescribed drills and timed writings on computer. Open entry/open exit. May be repeated.

\$2.00 material fee required for this course at registration.

1211501	8:00-9:55	MW	Hansen J	SAC A-226	Full Semester
1211502	9:00-1:05pm	TTh	Lehrer C	SAC A-226	1/8-1/31
1211503	9:00-1:10pm	F	Le N	SAC A-226	Full Semester
W 1211508	9:00-1:10pm	S	Banh H	SAC A-226	Full Semester
1211504	10:00-11:55	TTh	Nguyen M	SAC A-226	Full Semester
1211509	10:30-12:30pm	MW	Hansen J	SAC A-226	Full Semester
1211506	6:00-10:10pm	TTh	Nguyen M	SAC A-226	1/8-1/31
1211505	6:00-10:10pm	W	Lehrer C	SAC A-222	Full Semester
W 1211512	Hrs Arr		Hernandez M	SAC WEB	Full Semester

(Orientation Wed, Feb 13, 2pm and/or 6pm, SAC A-108. See Online Courses page in class schedule or go to www.sac.edu/disted for more information. Email instructor first week of class.)

BUSINESS APPLICATIONS 120, ADMINISTRATIVE OFFICE MANAGEMENT 3 UNITS

Introduces fundamentals of effective office management including basic principles of management, problem solving, systems thinking, communications, information technology, ergonomic environment, managing human resources, and office productivity.

1212001	7:00-10:10pm	W	Staff	SAC A-228	Full Semester
---------	--------------	---	-------	-----------	---------------

BUSINESS APPLICATIONS 125, MICROSOFT WORD BASICS 1.5 UNITS

Basic procedures for creating, editing, and manipulating documents of varying sophistication using Microsoft Word software. Prepares student for Microsoft Word Certification.

\$2.00 material fee required for this course at registration.

(Software Utilized: Word 2007)

W 1212501	9:00-12:05pm	S	Magarro J	SAC A-228	4/19-6/7
-----------	--------------	---	-----------	-----------	----------

BUSINESS APPLICATIONS 147, INTRODUCTION TO WINDOWS 1.5 UNITS

The fundamentals of graphical user interface including using Help, launching applications, managing files and folders. Students will use Windows Help, with My Computer and Explorer. Additional accessories include Control Panel, Word Pad, Character Map, and Communications.

\$2.00 material fee required for this course at registration.

(Software Utilized: Windows Vista)

1214703	9:15-10:40	TTh	Negrete T	SAC A-224	2/12-4/3
W 1214702	6:30-9:40pm	F	Ali W	SAC A-222	2/15-4/4
1214701	7:00-10:10pm	MW	Nguyen M	SAC A-222	1/7-1/30

BUSINESS APPLICATIONS 148, ADVANCED WINDOWS 1.5 UNITS

Continued instruction in Microsoft Windows features. Topics include: Windows accessory applications, using Paint, sharing data, multimedia accessories, using Internet Explorer and the Web, editing the Strat menu, adding additional components and maintaining your system.

\$2.00 material fee required for this course at registration.

(Software Utilized: Windows Vista)

1214802	9:15-10:40	TTh	Negrete T	SAC A-224	4/15-6/5
W 1214801	6:30-9:40pm	F	Ali W	SAC A-222	4/18-6/6

Online Counseling Now Available!
www.sac.edu/online_counseling

TKT#	TIME	DAYS	INSTRUCTOR	LOC./RM.	DATES
------	------	------	------------	----------	-------

BUSINESS APPLICATIONS 160, MICROSOFT PUBLISHER 3 UNITS

Easy-to-use program that guides you through the process of creating brochures, newsletters, invitations and flyers. Create professional-looking documents without graphic design training. Use a scanner to incorporate graphics in your documents.

\$4.00 material fee required for this course at registration.
(Software Utilized: Publisher 2007)

1216001	7:00-10:10pm	W	Negrete T	SAC A-226	Full Semester
---------	--------------	---	-----------	-----------	---------------

BUSINESS APPLICATIONS 164, INTRODUCTION TO ADOBE PHOTOSHOP 3 UNITS

Learn how to use Photoshop, image editing program, on the P.C. to create, edit, and prepare high impact images for your documents.

\$4.00 material fee required for this course at registration.
(Software Utilized: Adobe Photoshop CS2)

1216402	7:00-10:10pm	M	Thorey V	SAC A-224	Full Semester
---------	--------------	---	----------	-----------	---------------

BUSINESS APPLICATIONS 166, ADOBE ILLUSTRATOR 3 UNITS

Introduction to Adobe Illustrator, an electronic digital illustration program for creating graphic images for business publications. Learn how to digitally create and print illustrations, logos, and publications.

\$4.00 material fee required for this course at registration.
(Software Utilized: Adobe Illustrator CS2)

1216601	7:00-10:10pm	T	Thorey V	SAC A-224	Full Semester
---------	--------------	---	----------	-----------	---------------

BUSINESS APPLICATIONS 167, ADOBE PHOTOSHOP APPLICATIONS 3 UNITS

Learn how to use advanced features of Photoshop and how to integrate the results with other computer and digital programs in order to create a project ready for real world application. Students should have prior knowledge of Photoshop software.

\$4.00 material fee required for this course at registration.
(Software Utilized: Photoshop CS2)

1216701	7:00-10:10pm	W	Thorey V	SAC A-224	Full Semester
---------	--------------	---	----------	-----------	---------------

BUSINESS APPLICATIONS 179, INTRODUCTION TO MICROSOFT OFFICE 3 UNITS

Learn the basics of Microsoft Office, a suite of applications for Windows (Word, Excel, Access and PowerPoint). Acquire skills for creating, formatting, printing and editing documents.

\$4.00 material fee required for this course at registration.
(Software Utilized: Office 2007)

1217908	9:00-12:10pm	F	Singer D	SAC A-222	Full Semester
1217907	9:30-10:55	MW	Nguyen M	SAC A-222	Full Semester
1217904	9:30-10:55	TTh	Lehrer C	SAC A-228	Full Semester
1217906	11:00-12:25pm	TTh	Lehrer C	SAC A-228	Full Semester
1217909	1:10-2:35pm	MW	Singer D	SAC A-226	Full Semester
1217905	7:00-10:10pm	M	Singer D	SAC A-228	Full Semester
1217903	7:00-10:10pm	Th	Nguyen M	SAC A-226	Full Semester
1217902	Hrs Arr		Hernandez M	SAC WEB	Full Semester

(Orientation Tues, Feb 12, 6pm, SAC A-104 and/or Thurs, Feb 14, 1:30pm, SAC A-108.
See Online Courses page in class schedule or go to www.sac.edu/disted for more information. Email instructor first week of class.)

BUSINESS APPLICATIONS 180, ADVANCED MICROSOFT OFFICE 3 UNITS

Expand your knowledge of the integrated use of Microsoft Office applications. Instruction will include the integration and advanced applications of Microsoft Office. Working knowledge of office recommended.

\$4.00 material fee required for this course at registration.
(Software Utilized: Office 2007)

1218001	Hrs Arr		Nguyen M	SAC WEB	Full Semester
AND	1 Hr Arr		Staff	SAC A-104	

(Mandatory orientation Wed, Feb 13, 7pm and/or Thurs, Feb 14, 1pm, SAC A-104.
See Online Courses page in class schedule or go to www.sac.edu/disted for more information. Email instructor first week of class.)

TKT#	TIME	DAYS	INSTRUCTOR	LOC./RM.	DATES
------	------	------	------------	----------	-------

BUSINESS APPLICATIONS 183, MICROSOFT WORD 3 UNITS

Step-by-step procedures are taught for creating, editing, and printing business documents with Microsoft Word. Ability to type is recommended.

\$4.00 material fee required for this course at registration.
(Software Utilized: Word 2007)

1218302	Hrs Arr		Nguyen M	SAC WEB	Full Semester
					(Mandatory orientation Wed, Feb 13, 7pm and/or Thurs, Feb 14, 1pm, SAC A-104. See Online Courses page in class schedule or go to www.sac.edu/disted for more information. Email instructor first week of class.)

BUSINESS APPLICATIONS 185, REAL WORLD MICROSOFT OFFICE PROJECTS 3 UNITS

Integration of the Microsoft Office programs including: Word, Excel, Powerpoint, Access and Outlook. Students work in a simulated business organization to complete project-based documents. Students will reinforce and build their software skills, improve Internet skills and develop teamwork and critical-thinking skills.

1218501	7:00-10:10pm	M	Lehrer C	SAC A-226	Full Semester
AND	Hrs Arr		Lehrer C	SAC WEB	

(Tckt. No 1218501 will have mandatory meetings Mon, Feb 11, 8:30 to 10pm, Mar 3, 17, 31, Apr 21, May 5, 19, Jun 2, 7-10pm, SAC A-226. See Online Courses page in class schedule or go to www.sac.edu/disted for more information.)

BUSINESS APPLICATIONS 188, MICROSOFT EXCEL 1.5 UNITS

Introduction to Excel spreadsheets including formatting, graphics, and formulas common to business applications. Prepares student for MS Excel Certification.

\$2.00 material fee required for this course at registration.
(Software Utilized: Excel 2007)

1218803	Hrs Arr		Nguyen M	SAC WEB	2/11-3/31
					(Mandatory orientation Thurs, Feb 14, 1:30pm and/or 5:30pm, SAC A-104. See Online Courses page in class schedule or go to www.sac.edu/disted for more information. Email instructor first week of class.)
1218802	9:00-12:10pm	TTh	Nguyen M	SAC A-222	1/8-1/31
1218801	9:00-12:10pm	S	Santoyo P	SAC A-224	2/16-4/5
1218805	6:30-9:35pm	F	Nguyen T	SAC A-228	4/18-6/6

BUSINESS APPLICATIONS 189, EXCEL APPLICATION PROJECTS 1.5 UNITS

Course will provide an opportunity to develop a typical job-related Excel project. It will allow students to expand problem-solving skills with Excel software. Recommended experience with Excel.

\$2.00 material fee required for this course at registration.
(Software Utilized: Excel 2007)

1218901	9:00-12:10pm	S	Santoyo P	SAC A-224	4/19-6/7
---------	--------------	---	-----------	-----------	----------

BUSINESS APPLICATIONS 190, MICROSOFT POWERPOINT 1.5 UNITS

Instruction in the essentials of presentation graphics using PowerPoint. Students will learn how to design and produce presentation material for business including transparencies, slide and screen shows.

\$2.00 material fee required for this course at registration.
(Software Utilized: PowerPoint 2007)

1219002	9:30-11:00	MW	Staff	SAC A-224	2/11-4/2
1219004	Hrs Arr		Osgood J	SAC WEB	2/11-4/4

(See Online Courses page in class schedule or go to www.sac.edu/disted for more information. Email instructor first week of class.)

BUSINESS APPLICATIONS 191, POWERPOINT-APPLICATION PROJECTS 1.5 UNITS

Course will provide an opportunity to develop original presentation projects for business, job or personal use. Course is designed to allow students an opportunity to expand knowledge of PowerPoint.

\$2.00 material fee required for this course at registration.
(Software Utilized: PowerPoint 2007)

1219102	9:30-11:00	MW	Staff	SAC A-224	4/14-6/4
1219101	Hrs Arr		Lehrer C	SAC WEB	4/14-6/8

(Orientation Wed, Apr 16, 5pm, SAC A-108. See Online Courses page in class schedule or go to www.sac.edu/disted for more information. Email instructor first week of class.)

BUSINESS APPLICATIONS 192, INTRODUCTION TO MICROSOFT PROJECT 3 UNITS

Students will learn how to plan a project, create project schedules, communicate project information, use the critical path, assign resources, track progress, and share information across applications and the web using Microsoft Project.

\$4.00 material fee required for this course at registration.
(Software Utilized: Office Project 2007)

1219201	7:00-10:10pm	M	Staff	SAC A-222	Full Semester
---------	--------------	---	-------	-----------	---------------

BUSINESS APPLICATIONS 198, CREATING WEB PAGES WITH FLASH AND DREAMWEAVER 3 UNITS

Provides instruction on designing a dynamic web site from concept to upload to a server using Dreamweaver and Flash together. Students will integrate HTML with multimedia into one web site using cascading style sheets, animation, and sound based on professional business standards and techniques. Knowledge of Word and Photoshop helpful.

(Software Utilized: Dreamweaver and Flash Adobe CS2)

1219805	7:00-10:10pm	Th	Dumon D	SAC A-224	Full Semester
---------	--------------	----	---------	-----------	---------------

Can't find the class you need?

**It may be waiting for you at
Santiago Canyon College!**

**View SCC's class schedule at
www.sccollege.edu/schedule**

SCC's class schedule is included in this booklet.

Hurry! Class sizes are limited.

TKT#	TIME	DAYS	INSTRUCTOR	LOC./RM.	DATES
------	------	------	------------	----------	-------

BUSINESS APPLICATIONS 198, INTRODUCTION TO GEOGRAPHIC INFORMATION SYSTEMS 3 UNITS

This course is an introduction to the concepts and uses of Geospatial Information Systems (GIS). Topics include the history of GIS, GIS data sources, and GIS applications. Students will use ESRI's ArcView 9.1 software for business applications.

1219801	7:00-10:10pm	T	Crowley D	SAC A-222	Full Semester
AND	Hrs Arr		Crowley D	SAC WEB	

(Online instruction plus mandatory on-campus meetings. Students must attend all of the following on-campus meetings, Tues, Feb 12, 19, Mar 4, 18, Apr 1, 22, May 6, 20, Jun 3, 7pm, SAC A-222. Email instructor first week of class.)

BUSINESS APPLICATIONS 198, INTERMEDIATE GEOGRAPHIC INFORMATION SYSTEMS 3 UNITS

This intermediate course provides further study in ArcView, it is a continuation of the skills and concepts learned in Introduction to Geographic Information Systems (GIS). Course work is based on the mapping and spatial analysis capabilities of ArcView software. Students will be creating and editing spatial data, geocode data, perform spatial data processing and conduct spatial analysis.

1219802	7:00-10:10pm	T	Crowley D	SAC A-222	Full Semester
AND	Hrs Arr		Crowley D	SAC WEB	

(Online instruction plus mandatory on-campus meetings. Students must attend all of the following on-campus meetings, Tues, Feb 12, 26, Mar 11, 25, Apr 15, 29, May 13, 27, Jun 3, 7pm, SAC A-222. Email instructor first week of class.)

BUSINESS INFORMATION SCIENCE (SEE BUSINESS APPLICATIONS & COMPUTER SCIENCE)

CATERING

CATERING 062, BASIC TECHNIQUES OF COOKING 2 UNITS

Basic techniques and principles of food preparation are practiced in skill applied laboratory. (Same as Nutrition and Food 062.)

1306201	6:00-10:15pm	T	Marshall M	SAC T-212	Full Semester
---------	--------------	---	------------	-----------	---------------

CATERING 299, COOPERATIVE WORK EXPERIENCE EDUCATION 1-4 UNITS

Supervised catering field experience with new tasks in major. One unit/5 hours worked/week. Limit 4 units in Catering cooperative education classes. Must enroll in minimum of 7 units. Students must attend ONE orientation meeting. (Same as Nutrition & Food 299). Grade: CR/NCR only. Prerequisite: 6 units of Catering courses.

1329902	1:35-2:45pm	T	Warner K	SAC T-201	Full Semester
---------	-------------	---	----------	-----------	---------------

CARDIOPULMONARY RESUSCITATION (SEE EXERCISE SCIENCE - HEALTH EDUCATION)

CAREER PLANNING (SEE COUNSELING)

CHEMISTRY

Completion of English 061 or 101 or the equivalent is highly recommended prior to enrollment in any Chemistry course.

CHEMISTRY 090, CHEMICAL CONCEPTS FOR BIOLOGY 1 UNIT

No prior chemistry needed. For majors in nursing, biology, and similar programs. Introductory basic facts and concepts. Descriptive chemistry of atoms, organic and biochemistry (without math) as used in beginning biology classes.

1409002	9:00-11:05	F	Nguyen W	SAC R-124	2/11-4/6
---------	------------	---	----------	-----------	----------

Meet your Physical Science requirement!!! Take Chemistry 109.

CHEMISTRY 109, CHEMISTRY IN THE COMMUNITY 4 UNITS

For non-science majors. Basic chemistry and scientific principles. Student-centered discussion and decision making of individual and community issues. (Same as Environmental Studies 109.)

1410903	9:00-12:10pm	MTWTh	Nguyen W	SAC R-318	1/7-1/31
AND	1:00-4:10pm	MTWTh	Nguyen W	SAC R-309	

CHEMISTRY 109

Chemistry 10 classes are available in Freshman Experience and Learning Communities II. Enrollment in all classes within a block is required. For additional information see page 26.

U-LINK

CHEMISTRY 109

1410902	1:00-2:25pm	MW	Kelcher M	SAC R-126	Full Semester
AND LAB	3:00-6:10pm	M	Kelcher M	SAC R-309	

COUNSELING 128

2012801	9:00-10:30	MW	Zook R	SAC B-29	Full Semester
---------	------------	----	--------	----------	---------------

The course that emphasizes Physical Sciences for Elementary School Teachers is now called Physical Science 115.

TKT#	TIME	DAYS	INSTRUCTOR	LOC./RM.	DATES
------	------	------	------------	----------	-------

Meet your Chemistry (Science Majors) requirements!!!

Take the following in the order given:

- Chemistry 209
- Chemistry 219
- Chemistry 229
- Chemistry 249
- Chemistry 259

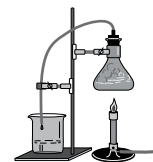

CHEMISTRY 119, FUNDAMENTALS-GENERAL & ORGANIC (CAN CHEM 6) 5 UNITS

No prior chemistry needed. For majors in nursing, biology, pharmacy technology, family and consumer studies, dietetics, and physical education. Prerequisite: Mathematics 060.

Chemistry 119 does not meet the prerequisite for Chemistry 219. The prerequisite for Chemistry 219 is Chemistry 209.

1411902	7:00-10:10pm	T	Joe S	SAC R-126	Full Semester
AND	7:00-10:10pm	Th	Joe S	SAC R-309	
AND	6:00-6:55pm	Th	Joe S	SAC R-114	

CHEMISTRY 209, INTRODUCTORY CHEMISTRY 4 UNITS

Basic concepts of atoms, formulas, moles, gases, and solutions. Prepares students for biology and Chemistry 219. Prerequisite: Mathematics 080 with a grade of C or better.

1420907	9:00-12:10pm	S	Moore B	SAC R-318	Full Semester
AND	12:30-3:40pm	S	Moore B	SAC R-309	
1420909	9:30-12:40pm	MTWTh	Jenkins C	SAC R-126	1/7-1/31
AND	1:10-4:20pm	MTWTh	Jenkins C	SAC R-126	
1420908	11:10-12:35pm	TTh	Jenkins C	SAC R-128	Full Semester
AND	11:30-2:40pm	W	Jenkins C	SAC R-301	
1420903	11:15-12:40pm	MW	McMillan J	SAC R-126	Full Semester
AND	1:30-4:40pm	M	McMillan J	SAC R-301	
1420901	3:00-4:25pm	TTh	Kelcher M	SAC R-126	Full Semester
AND	3:15-6:25pm	W	Kelcher M	SAC R-301	
1420911	5:30-6:55pm	MW	Pratt C	SAC R-128	Full Semester
AND	7:00-10:10pm	M	Pratt C	SAC R-301	
1420904	7:00-10:10pm	M	Edinger W	SAC R-318	Full Semester
AND	7:00-10:10pm	W	Edinger W	SAC R-301	
1420906	7:00-10:10pm	T	Shugarman A	SAC R-309	Full Semester
AND	7:00-10:10pm	Th	Shugarman A	SAC R-318	

CHEMISTRY 219, GENERAL CHEMISTRY (CHEM 2) (CHEM SEQ A) 5 UNITS

Principles of chemistry; analytical approach to problem solving. Mathematics 160 strongly recommended. Prerequisite: Passing score on RSCCD Chemistry Placement Test and Mathematics 080 or Chemistry 209 and Mathematics 080 with grades of C or better.

1421903	1:30-2:55pm	TTh	Nguyen W	SAC R-318	Full Semester
AND	8:30-11:40	MW	Nguyen W	SAC R-309	
1421901	5:30-6:55pm	MW	Visco L	SAC R-126	Full Semester
AND	7:00-10:10pm	MW	Visco L	SAC R-309	

CHEMISTRY 219

Chemistry 219 classes are available in Freshman Experience and Learning Communities II. Enrollment in all classes within a block is required. For additional information see page 26.

MESA

CHEMISTRY 219

1421902	9:30-10:55	MW	McMillan, J	SAC R-126	Full Semester
AND LAB	9:00-12:10pm	TTh	McMillan, J	SAC R-309	

COUNSELING 111

2011110	9:00-10:50	F	Scharf, M.	SAC R-303	Full Semester
---------	------------	---	------------	-----------	---------------

CHEMISTRY 229, GENERAL CHEMISTRY AND QUALITATIVE ANALYSIS (CHEM 4) (CHEM SEQ A) 5 UNITS

Continuation of Chemistry 219 including thermodynamics and electrochemistry. Prerequisite: Chemistry 219 with a grade of C or higher.

1422906	1:00-2:25pm	TTh	Jenkins C	SAC R-126	Full Semester
AND	2:45-5:55pm	TTh	Jenkins C	SAC R-301	
1422904	5:30-6:55pm	TTh	Kelcher M	SAC R-126	Full Semester
AND	7:00-10:10pm	TTh	Kelcher M	SAC R-301	

CHEMISTRY 249, ORGANIC CHEMISTRY I 5 UNITS

The first semester of a one-year course (Chemistry 249, 259). For physical and biological science majors. Prerequisite: Chemistry 229 with a grade of C or better.

1424901	3:30-4:55pm	MW	Nguyen W	SAC R-126	Full Semester
AND	12:00-3:10pm	MW	Nguyen W	SAC R-302	

CHEMISTRY 259, ORGANIC CHEMISTRY II 5 UNITS

The second semester of a full year course (Chemistry 249, 259). Prerequisite: Chemistry 249 with a grade of C or better.

1425901	5:15-6:40pm	MW	Yamada T	SAC R-124	Full Semester
AND	1:50-5:00pm	TTh	Yamada T	SAC R-302	
1425902	5:15-6:40pm	MW	Yamada T	SAC R-124	Full Semester
AND	7:00-10:10pm	TTh	Yamada T	SAC R-302	
1425903	5:15-6:40pm	MW	Yamada T	SAC R-124	Full Semester
AND	7:00-10:10pm	MW	Yamada T	SAC R-302	

CHICANO STUDIES

CHICANO STUDIES 101, INTRODUCTION TO CHICANO STUDIES 3 UNITS

An interdisciplinary survey of Chicano society from a sociological, economic, political, philosophical, and cultural perspective from pre-Columbian civilizations to contemporary society.

TKT#	TIME	DAYS	INSTRUCTOR	LOC./RM.	DATES
9730105	8:00-9:25	TTh	Briceno G	SAC B-31	Full Semester
9730103	9:45-11:10	MW	Sanchez G	SAC B-6	Full Semester
9730102	10:15-11:40	TTh	Briceno G	SAC D-206	Full Semester
9730101	7:00-10:10pm	W	Sanchez G	SAC D-105	Full Semester
9730104	7:00-10:10pm	Th	Briceno G	SAC D-208	Full Semester

CHILD DEVELOPMENT (SEE HUMAN DEVELOPMENT)

CLOTHING & TEXTILES (SEE FAMILY & CONSUMER STUDIES)

COMMUNICATIONS (SEE JOURNALISM/SPEECH/TV/VIDEO)

COMPUTER SCIENCE

SEE ALSO BUSINESS APPLICATIONS FOR SOFTWARE AND MULTIMEDIA COURSES

COMPUTER SCIENCE 100, THE COMPUTER & SOCIETY (CAN CSC2) 3 UNITS

Introduction to computer concepts, technology, issues and applications. Information is presented to enable students to recognize and evaluate the positive and negative impacts that computers may have on individuals and society. Students will learn the fundamentals of Internet research, e-mail, word processing, spreadsheet and database software using a PC.

\$4.00 material fee required for this course at registration.

(Software Utilized: MS Office 2007)

TKT#	TIME	DAYS	INSTRUCTOR	LOC./RM.	DATES
1710014	8:00-9:25	MW	Kushida C	SAC A-206	Full Semester
1710015	8:00-9:25	TTh	Nichols B	SAC A-213	Full Semester
1710028	8:00-11:10	F	Button C	SAC A-206	Full Semester
1710023	8:00-12:15pm	TWTh	Dahlen N	SAC A-206	1/8-1/31
1710020	9:30-10:55	MW	Kushida C	SAC A-206	Full Semester
1710018	10:00-11:25	MW	Nichols B	SAC A-213	Full Semester
1710004	10:30-11:55	MW	Hester J	SAC A-215	Full Semester
1710006	10:45-12:10pm	TTh	Hester J	SAC A-215	Full Semester
1710002	11:30-12:55pm	MW	Nichols B	SAC A-213	Full Semester
1710013	2:00-5:10pm	W	Hester J	SAC A-215	Full Semester
1710017	4:00-6:55pm	W	Dahlen N	SAC A-206	Full Semester
1710008	4:00-6:55pm	T	Dahlen N	SAC A-206	Full Semester
1710029	6:00-10:15pm	TWTh	Dahlen N	SAC A-206	1/8-1/31
1710016	7:00-10:10pm	M	Bennett J	SAC A-208	Full Semester
1710011	7:00-10:10pm	W	Staff	SAC A-208	Full Semester
1710010	7:00-10:10pm	Th	Lamb J	SAC A-206	Full Semester
1710019	Hrs Arr		Kushida C	SAC WEB	Full Semester

(Orientation Tues, Feb 12, 6:30pm and/or Wed, Feb 13, 1pm, SAC A-108. See Online Courses page in class schedule or go to www.sac.edu/disted for more information. Email instructor first week of class.)

COMPUTER SCIENCE 103, INTERNET & WORLD WIDE WEB ESSENTIALS 1.5 UNITS

Topics will include the use of e-mail, Web browsers, searching techniques, file transfer protocols, Internet resources, simple Web page development, ethics, security and the uses of various programming languages for the Internet.

\$2.00 material fee required for this course at registration.

(Software Utilized: MS Internet Explorer and Netscape Navigator)

TKT#	TIME	DAYS	INSTRUCTOR	LOC./RM.	DATES
1710309	Hrs Arr		Crowley D	SAC WEB	3/10-5/9

(Mandatory orientation Mon, Mar 3, 6:30pm, SAC A-104. See Online Courses page in class schedule or go to www.sac.edu/disted for more information. Email instructor first week of class.)

COMPUTER SCIENCE 104, COOPERATIVE WORK EXPERIENCE EDUCATION-OCCUPATIONAL 1-4 UNITS

Must be working for pay or volunteering in a position which includes new or expanded responsibilities and is related to student's major. Limit 16 units in Cooperative Education courses. Must enroll in 7 units. May be repeated. Grade: CR/NCR only.

TKT#	TIME	DAYS	INSTRUCTOR	LOC./RM.	DATES
1710401	Hrs Arr		Kushida C		Full Semester

(Email instructor before semester: kushida_cherylee@sac.edu)

COMPUTER SCIENCE 105, VISUAL BASIC PROGRAMMING 3 UNITS

Introduction to programming and Visual BASIC. Emphasis on programming fundamentals and the creation of applications with Visual BASIC. No previous programming experience required. Students will write programs on IBM PC compatible computers.

\$4.00 material fee required for this course at registration.

(Software Utilized: Microsoft Visual Basic.NET)

TKT#	TIME	DAYS	INSTRUCTOR	LOC./RM.	DATES
1710502	9:30-10:55	TTh	Nichols B	SAC A-213	Full Semester
1710505	7:00-10:10pm	T	Dahlen N	SAC A-206	Full Semester
1710504	7:00-10:10pm	W	Dahlen N	SAC A-206	Full Semester

TKT#	TIME	DAYS	INSTRUCTOR	LOC./RM.	DATES
------	------	------	------------	----------	-------

COMPUTER SCIENCE 111, INTRODUCTION TO COMPUTER ORGANIZATION 4 UNITS

Presents the organization and structure of computers at hardware and software levels: analysis and synthesis of combinatorial and sequential logic, data representation and manipulation, language structures and translation, and process administration and management. Recommended preparation: Computer Science 121 or equivalent.

TKT#	TIME	DAYS	INSTRUCTOR	LOC./RM.	DATES
1711102	6:00-10:10pm	W	Hester J	SAC A-210	Full Semester

COMPUTER SCIENCE 118, JAVASCRIPT PROGRAMMING 3 UNITS

Students will be introduced to the syntax of JavaScript, the methods used to incorporate JavaScript into HTML documents, and using JavaScripts to create interactive forms. Students will learn to enhance Web Pages through the use of Interactive Programming utilizing Forms, Frames, Documents, Windows, Loops, Strings, and Cookies.

\$4.00 material fee required for this course at registration.

(Software Utilized: MS Windows)

TKT#	TIME	DAYS	INSTRUCTOR	LOC./RM.	DATES
1711801	7:00-10:10pm	W	Bhattacharyya B	SAC A-213	Full Semester

COMPUTER SCIENCE 119, FUNDAMENTALS OF ASSEMBLY PROGRAMMING 4 UNITS

Structure of computers. Machine and assembly language programming. Hands-on experience. Recommended preparation: proficiency in a programming language.

\$4.00 material fee required for this course at registration.

(Software Utilized: MASM)

TKT#	TIME	DAYS	INSTRUCTOR	LOC./RM.	DATES
1711901	7:45am-9:50	MW	Nichols B	SAC A-213	Full Semester

COMPUTER SCIENCE 121, PROGRAMMING CONCEPTS 4 UNITS

Introduction to the C++ Programming language, data types, elementary input/output, sequence, choice, iteration, strings, arrays, functions and structure of algorithms. Students will use the C++ compiler on an IBM PC compatible. Prerequisite: Mathematics 080.

\$4.00 material fee required for this course at registration.

(Software Utilized: MS Visual C++ .NET)

TKT#	TIME	DAYS	INSTRUCTOR	LOC./RM.	DATES
1712105	8:30-10:35	TTh	Hester J	SAC A-215	Full Semester
1712106	6:00-10:10pm	M	Nichols B	SAC A-130	Full Semester

COMPUTER SCIENCE 141, UNIX OPERATING SYSTEM 3 UNITS

Introduction to computer operations using the UNIX and Linux operating systems. Includes the file system, shell programming and filters. Recommended preparation: Computer Science 121.

\$4.00 material fee required for this course at registration.

(Software Utilized: UNIX and Linux)

Lab facilities for the following class sections are not provided outside of the scheduled class hours

TKT#	TIME	DAYS	INSTRUCTOR	LOC./RM.	DATES
1714101	7:00-10:10pm	M	Morisutsu S	SAC A-213	Full Semester

COMPUTER SCIENCE 155, GRAPHIC DESIGN CONCEPTS FOR THE WEB 3 UNITS

Introduction to graphic design concepts for Web. Includes learning technical aspects of Web safe colors, file optimization, effects, images, slicing, rollovers, and applying the elements and principles of design. Includes creative Web design projects. Photoshop skill recommended. (Same as Art 129.)

\$4.00 material fee required for this course at registration.

TKT#	TIME	DAYS	INSTRUCTOR	LOC./RM.	DATES
1715503	9:00-1:15pm	F	Waterman P	SAC A-219	Full Semester
1715502	4:00-6:05pm	TTh	Nielsen C	DMC-104	Full Semester

COMPUTER SCIENCE 163, EXCEL 3 UNITS

Introduction to Microsoft Excel and how it facilitates solving business problems. Covers data management and reporting using spreadsheets, charts, database tools and macros.

\$4.00 material fee required for this course at registration.

(Software Utilized: Microsoft Excel 2007)

TKT#	TIME	DAYS	INSTRUCTOR	LOC./RM.	DATES
1716301	7:00-10:10pm	Th	Sterling M	SAC A-208	Full Semester

COMPUTER SCIENCE 167, MICROSOFT ACCESS 3 UNITS

Relational Database Management using Microsoft ACCESS. Includes design, creation and maintenance of a RDBMS, reports and form generation, queries, importing and exporting data, macros and modules using ACCESS Basic.

\$4.00 material fee required for this course at registration.

(Software Utilized: Microsoft Access 2007)

TKT#	TIME	DAYS	INSTRUCTOR	LOC./RM.	DATES
1716703	Hrs Arr		Kushida C	SAC WEB	Full Semester

(Orientation Tues, Feb 12, 5:45pm and/or Wed, Feb 13, 12:15pm, SAC A-108. See Online Courses page in class schedule or go to www.sac.edu/disted for more information. Email instructor first week of class.)



SOME COMPUTER CLASSES HAVE ARRANGED LAB HOURS

Students will be informed by their instructor if they are expected to spend a minimum of one hour per week in the computer lab. General Business and Computer Labs are available in A-104, A-106, and A-108 six days a week, and Accounting Labs are available at selected times in A-222 and A-228. Engineering Lab is available in A-225.

COMPUTER SCIENCE MAJOR REQUIREMENTS

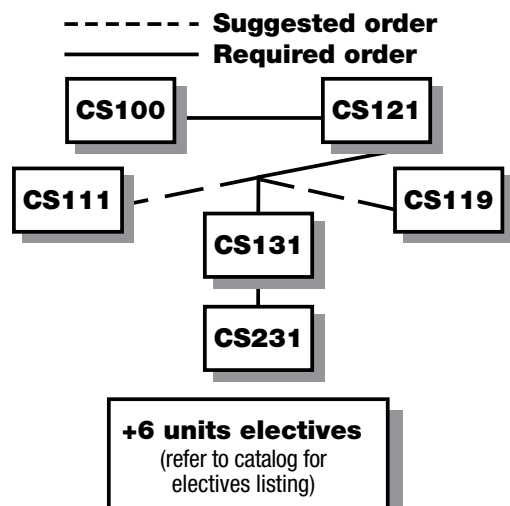

COMPUTER SCIENCE 168, ADVANCED ACCESS **3 UNITS**
Advanced Relational database Management using Microsoft Access. Includes application development using VBA, implementation in a multiuser environment and working with Access on the Internet. Computer Science 105 and 167 or equivalent experience is recommended.

\$4.00 material fee required for this course at registration.
(Software Utilized: MS Access 2007)

1716801	7:00-10:10pm	T	Habicht G	SAC A-215	Full Semester
---------	--------------	---	-----------	-----------	---------------

COMPUTER SCIENCE 173, INTRODUCTION TO NETWORKING TECHNOLOGY **3 UNITS**
A comprehensive overview of networking technology, including a history of LAN development and the uses and benefits of LANs. Students are introduced to LAN terminology, components, standards and upper level protocols.

\$4.00 material fee required for this course at registration.

1717302	7:00-10:10pm	T	Yaqub M	SAC B-16	Full Semester
---------	--------------	---	---------	----------	---------------

COMPUTER SCIENCE 198, WINDOWS SERVER 2003 **3 UNITS**
Installation, management and configuration of Windows Server 2003 as a stand alone operating system and as a client in a networked environment.

1719801	7:00-10:10pm	M	Ahmed A	SAC A-215	Full Semester
---------	--------------	---	---------	-----------	---------------

COMPUTER SCIENCE 198, PERSONAL COMPUTER TROUBLESHOOTING **3 UNITS**
Study of techniques and methods of PC maintenance. Topics include: The interaction between hardware and software; the motherboard and CPU; managing memory; disk drives; input and output and multimedia; printers; installation; management and supporting Windows; network and Internet connectivity; purchasing and building a PC; backups; viruses; and troubleshooting PC problems.

1719802	7:00-10:10pm	Th	Quach N	SAC A-213	Full Semester
---------	--------------	----	---------	-----------	---------------

COMPUTER SCIENCE 198, MICROSOFT SQL SERVER **3 UNITS**
Microsoft SQL Server, relational database concepts, programming with SQL and Transact-SQL, stored procedures, triggers, and use of client tools. Course is designed for developers and database administrators. Basic knowledge of SQL, programming and/or database concepts is helpful.

1719803	7:00-10:10pm	M	Sabetiashraf R	SAC A-206	Full Semester
---------	--------------	---	----------------	-----------	---------------

COMPUTER SCIENCE 198, WINDOWS VISTA OPERATING SYSTEM **3 UNITS**
Windows Vista Operating System (Business and Enterprise). Course topics include: Installation and Configuration, Application Installation and Management, Hardware Configurations, File and Information Management, Security, Managing User Accounts, Networking, Digital Media, System Maintenance and Management, Desk Top Management and Configuration.

1719805	7:00-10:10pm	T	Shah A	SAC A-213	Full Semester
---------	--------------	---	--------	-----------	---------------

COMPUTER SCIENCE 198, FOUNDATIONS OF INTERACTIVE GAME DESIGN **3 UNITS**
History and theory of interactive game design with emphasis on computer game design. Students will learn to use a simple object oriented game development tool to prototype and build simple games. Open to all majors. Students must have strong reading, writing, and communications skills.

1719806	7:00-10:10pm	T	Nichols B	SAC A-210	Full Semester
---------	--------------	---	-----------	-----------	---------------

COMPUTER SCIENCE 198, HELP DESK SKILLS **1.5 UNITS**
Introduction to Help Desk "soft skills," non-IT related business, such as effective communication, analytical thinking, diplomacy, problem solving, leadership, team building, and listening skills. In addition to learning necessary soft skills, students will be familiar with a help-desk environment, its function and organization.

1719804	7:00-10:10pm	T	Singer D	SAC A-226	4/15-6/3
---------	--------------	---	----------	-----------	----------

COMPUTER SCIENCE 231, FILE SYSTEM CONCEPTS **3 UNITS**
Structured design approach to creating, maintaining, and processing of sequential, random, and indexed files. Characteristics and utilization of bulk storage devices. B-trees, sequential and random access methods. Object Oriented Programming design and implementation. Applications will be written using C++. Prerequisite: Computer Science 131.

\$4.00 material fee required for this course at registration.

(Software Utilized: MS Visual C++ .NET)

1723102	7:00-10:10pm	M	Staff	SAC A-210	Full Semester
---------	--------------	---	-------	-----------	---------------

COMPUTER SCIENCE 241, UNIX SYSTEM ADMINISTRATION **3 UNITS**
How to administer and maintain a UNIX operating system. Includes system-wide commands, set-up devices, troubleshooting, and system monitoring. Prerequisite: Computer Science 141.

\$4.00 material fee required for this course at registration.

(Software Utilized: JDK 1.1)

1724101	7:00-10:10pm	Th	Moritsugu S	SAC A-215	Full Semester
---------	--------------	----	-------------	-----------	---------------

COMPUTER SCIENCE 243, UNIX SYSTEM PROGRAMMING **3 UNITS**
Study of UNIX Systems Programming. UNIX C libraries, development tools, spawning processes, inter-process communication, programming with sockets. Completion of Computer Science 121 and 141 is recommended.

1724301	7:00-10:10pm	W	Moritsugu S	SAC A-215	Full Semester
---------	--------------	---	-------------	-----------	---------------

COUNSELING

COUNSELING 100, LIFELONG UNDERSTANDING AND SELF DEVELOPMENT **2 UNITS**
Integrates concepts of lifelong understanding as they pertain to career choice, educational planning and self-inventory.

2010016	8:30-10:35	F	Groff R	SAC A-214	Full Semester
2010003	8:30-12:45pm	TTh	Vargas M	SAC A-203	1/8-1/31
2010008	9:00-9:55	MW	Coffman J	SAC B-30	Full Semester
2010002	6:00-8:05pm	M	Brown A	SAC B-32	Full Semester
2010012	6:00-10:15pm	T	Castellanos M	SAC B-30	2/12-4/1

COUNSELING 110, UNIVERSITY TRANSFER RESEARCH **0.5-2 UNITS**
Development/enhancement of decision-making strategies for transfer students. Identification of educational/career goals. Analysis, comparison and evaluation of entrance/major/post-graduate requirements and services. On-site research/field study at universities. May be repeated.

2011001	8:00-4:50pm	MTWTh	Guzman I	SAC S-CPC	2/5-2/8
2011002	8:00-4:50pm	MTWTh	Zook R	SAC S-CPC	2/5-2/8



UNIVERSITY TRANSFER CENTER

Transfer is not a mystery. It's a process.
Let us help YOU get to where YOU want to go!

The University Transfer Center provides information and assistance to students who are preparing to transfer to four-year colleges and universities.

MESA: The MESA Program is an academic program that supports students to excel in math, engineering, computer science and science so they can transfer to a four-year university or college. Services include tutoring, advisement, workshops, and scholarships.

PUEENTE: The Puente Program provides students with English instruction (English 061 & English 101), academic counseling and mentoring.

TEACHER ED: The Center for Teacher Education is dedicated to providing a variety of outreach, retention, and transfer activities for future teachers.

U-LINK: This program is open to all students, particularly students in the Santa Ana Unified School District. ULINK is a guaranteed transfer admission from Santa Ana College to UCI.

For further information, visit the University Transfer Center (S-132), on the web at www.sac.edu the select "University Transfer Center" or call (714) 564-6165.

Online Counseling Now Available!
www.sac.edu/online_counseling

TKT#	TIME	DAYS	INSTRUCTOR	LOC./RM.	DATES
------	------	------	------------	----------	-------

COUNSELING 114, CAREERS IN TEACHING 1 UNIT

Introductory course for a career in teaching. Topics include an overview of the teaching profession, academic preparation, credentials, career ladders, and goal setting principles. Students will participate in career assessments, formulate a career objective, and develop an educational plan.

2011402	4:00-6:05pm	Th	Nguyen M	SAC B-13	4/17-6/5
2011401	4:45-6:50pm	Th	Bautista S	SAC A-205	2/14-4/3

COUNSELING 116, CAREER/LIFE PLANNING AND PERSONAL EXPLORATION 3 UNITS

Covers theories and concepts of values, interests, skills and personality as applied to career-life planning process. Short/long-term career/life plans will be developed along with an awareness of diversity within the workplace.

\$20.00 material fee required for this course at registration.

2011674	8:00-9:25	MW	Lockhart A	SAC A-215	Full Semester
2011608	8:00-9:25	TTh	Sadler D	SAC A-226	Full Semester
2011612	8:00-9:25	TTh	Quintana R	SAC B-29	Full Semester
2011615	9:00-12:10pm	F	Quintana R	SAC B-29	Full Semester
2011627	9:00-12:10pm	S	Vinopal J	SAC A-206	Full Semester
2011603	9:30-10:55	MW	Pham T	SAC R-115	Full Semester
2011630	9:30-10:55	MW	Gallego R	SAC B-13	Full Semester
2011604	9:30-10:55	TTh	Quintana R	SAC B-29	Full Semester
2011618	9:30-10:55	TTh	Gilmour D	SAC R-115	Full Semester
2011610	11:00-12:25pm	MW	Pham T	SAC R-115	Full Semester
2011631	11:00-12:25pm	MW	Gallego R	SAC B-13	Full Semester
2011642	11:00-12:25pm	MW	Vercelli J	SAC B-11	Full Semester
2011632	11:00-12:25pm	TTh	Quintana R	SAC B-29	Full Semester
2011611	6:00-9:10pm	M	Sadler D	SAC B-31	Full Semester
2011616	6:00-9:10pm	T	Vu J	SAC R-115	Full Semester
2011617	6:00-9:10pm	Th	Mugica Y	SAC D-307-1	Full Semester
2011650	6:00-10:15pm	TWTh	Castellanos M	SAC A-207	1/8-1/31
2011624	7:00-10:10pm	W	Gilmour D	SAC R-113	Full Semester
2011651	Hrs Arr		Sadler D	SAC WEB	1/8-1/31

(Students must attend one of the following orientations: Jan 2, 3, or 8, 7-9pm, or Jan 8, 12-2pm, SAC L-225. For additional information contact the instructor, sadler_dennis@sac.edu or www.sac.edu/students/counseling/staff/sadler.htm.)

2011660	Hrs Arr		Sadler D	SAC WEB	Full Semester
---------	---------	--	----------	---------	---------------

(Students must attend one of the following orientations: Feb 5, 12, or 19, 7-9 pm, or Feb 12, or 19, 12-2pm, SAC L-225. For additional information contact the instructor, sadler_dennis@sac.edu or www.sac.edu/students/counseling/staff/sadler.htm.)

COUNSELING 120, ASSERTIVE SELF DEVELOPMENT 3 UNITS

A process for building self esteem, confidence and skills in personal/social/professional interactions without feeling excess anger, guilt, stress or passivity. Psychological theories will be used to identify, analyze, and change ineffective thought systems and behavior.

2012002	6:00-9:10pm	M	Nguyen T	SAC B-13	Full Semester
---------	-------------	---	----------	----------	---------------

COUNSELING 144, REASONING AND PROBLEM SOLVING 3 UNITS

Development of basic skills in critical thinking with emphasis on reasoning, problem solving, decision making, causation, hypothesis testing and models of thinking. (Same as Philosophy 144.)

2014401	8:00-9:25	MW	Pearson C	SAC R-115	Full Semester
2014402	8:00-9:25	TTh	Pearson C	SAC A-214	Full Semester
2014450	8:00-12:15pm	TWTh	Pearson C	SAC R-115	1/8-1/31
2014403	9:30-10:55	TTh	Pearson C	SAC A-214	Full Semester
2014407	11:00-12:25pm	MW	Pearson C	SAC R-303	Full Semester
2014451	6:00-10:15pm	TWTh	Pearson C	SAC R-115	1/8-1/31

COUNSELING 150, INTRODUCTION TO HUMAN SERVICES 3 UNITS

The history and philosophy of human services including theoretical frameworks, the function and orientation of human service organizations and the roles and qualifications of human service workers.

2015001	12:30-3:40pm	W	Gilmour D	SAC A-207	Full Semester
---------	--------------	---	-----------	-----------	---------------

COUNSELING 198, SKILLS FOR THE HELPING PROFESSIONALS 3 UNITS

An exploration of processes for increasing mental flexibility and assisting people in getting resolution on life issues.

2019801	6:00-9:10pm	T	Gilmour D	SAC B-17	Full Semester
---------	-------------	---	-----------	----------	---------------

Can't find the class you need?

**It may be waiting for you at
Santiago Canyon College!**

**View SCC's class schedule at
www.sccollege.edu/schedule**

SCC's class schedule is included in this booklet.

Hurry! Class sizes are limited.

TKT#	TIME	DAYS	INSTRUCTOR	LOC./RM.	DATES
------	------	------	------------	----------	-------



**Imagine it, become it!
Plan your academic future**

By enrolling in a counseling class you'll learn:

- UC and CSU requirements
- Choosing a major
- Where to transfer

Counseling 100

Lifelong Understanding and Self Development

Counseling 110

University Transfer Research

Includes a trip to Northern UC campuses!

Counseling 120

Assertive Self Development

Counseling 116

Career/Life Planning and Personal Development

We also offer Counseling Classes Online!

Students must attend one of the following orientations for online sections of Counseling 116:

February 5, 12 or 19, 7-9pm or February 12 or 19, 12-2pm

All courses meet A.A. and CSU Gen Ed requirements.

CRIMINAL JUSTICE

CRIMINAL JUSTICE 048, WRITING SKILLS FOR CRIMINAL JUSTICE PERSONNEL 3 UNITS

To develop practical, precise report writing techniques as well as general writing skills applicable to law enforcement and corrections. Prerequisite: Satisfactory score on English placement test and in-class writing sample or C grade or better in English N60.

2204802	9:00-12:10pm	F	Goldsmith C	SAC R-114	Full Semester
2204801	6:00-9:10pm	W	Frazee B	SAC R-307	Full Semester

CRIMINAL JUSTICE 095, DRUG USE AND IDENTIFICATION 1 UNIT

Techniques of investigation regarding recognition, identification and effects of illegal drugs.

W 2209501	8:00-4:50pm	S	Gallardo R	SAC R-114	2/23-3/15
-----------	-------------	---	------------	-----------	-----------

CRIMINAL JUSTICE 098, TERRORISM 1 UNIT

A course which focuses on international and domestic terrorism with emphasis on cause, effect and proper investigation techniques.

W 2209802	8:00-4:50pm	S	Sterett R	SAC R-114	3/22-4/19
-----------	-------------	---	-----------	-----------	-----------

**Academic Planning Questions?
www.sac.edu/online_counseling**

TKT#	TIME	DAYS	INSTRUCTOR	LOC./RM.	DATES
------	------	------	------------	----------	-------

CRIMINAL JUSTICE 098, STREET GANGS 2 UNITS

A course which focuses on street gangs in the U.S. with emphasis on California and the local area. Topics include but are not limited to Hispanic, Asian, African American, taggers, hate groups and prison gangs.

W 2209801	8:00-4:50pm	S	Valdez A	SAC R-114	4/26-5/17
-----------	-------------	---	----------	-----------	-----------

CRIMINAL JUSTICE 101, INTRODUCTION TO CRIMINAL JUSTICE (CAN AJ 2) 3 UNITS

An in-depth study of the philosophy and history of the criminal justice system; including law enforcement, the courts, and corrections.

2210114	8:00-9:25	MW	Gonis A	SAC A-207	Full Semester
2210117	8:00-11:20	MTWTh	Gonis A	SAC H-207	1/7-1/31
2210109	9:00-12:10pm	F	Davis R	SAC R-318	Full Semester
W 2210105	9:00-12:10pm	S	Bell T	SAC H-205	Full Semester
2210101	9:30-10:55	TTh	Wright G	SAC R-124	Full Semester
2210102	11:00-12:25pm	MW	Gonis A	SAC A-207	Full Semester
2210112	11:00-12:25pm	TTh	Pena R	SAC A-214	Full Semester
2210108	6:00-9:10pm	M	Small S	SAC H-205	Full Semester
2210106	7:00-10:10pm	W	Wright G	SAC W-101	Full Semester
2210113	Hrs Arr		Troxcil G	SAC WEB	Full Semester

(Tckt No 2210113 will have a MANDATORY meeting either Mon, Feb 11 or Tues Feb 12, 6pm, OCST, 15991 Armstrong Avenue, Tustin 92782. Email instructor by Fri, Feb 8 or call 714-566-9201.)

2210115	Hrs Arr		Troxcil G	SAC WEB	Full Semester
---------	---------	--	-----------	---------	---------------

(Tckt No 2210115 will have a MANDATORY meeting either Mon, Feb 11 or Tues, Feb 12, 6pm, OCST, 15991 Armstrong Avenue, Tustin 92782. Email instructor by Fri, Feb 8 or call 714-566-9201.)

2210116	3:00-5:05pm	MW	Lee J	SAHS	3/3-5/28
---------	-------------	----	-------	------	----------

CRIMINAL JUSTICE 102, INTRODUCTION TO CORRECTIONS 3 UNITS

A course designed to familiarize the student in dealing with adult offenders inside an institution.

2210201	6:30-9:40pm	W	Glenane R	SAC F-103	Full Semester
---------	-------------	---	-----------	-----------	---------------

CRIMINAL JUSTICE 103, CONCEPTS OF CRIMINAL LAW 3 UNITS

Criminal law definitions, classifications, basic concepts, and their application to the system of justice administration.

2210302	10:00-11:25	TTh	Gonis A	SAC H-207	Full Semester
2210301	6:00-9:10pm	Th	Caddell A	SAC B-5	Full Semester
2210303	Hrs Arr		Gonis A	SAC WEB	Full Semester

(Tckt No 2210303 will have an orientation meeting 6:30-7:30pm, Tues, Feb 12, SAC F-102. Email instructor first week of class. See Online Courses page in class schedule or go to www.sac.edu/disted for more information.)

CRIMINAL JUSTICE 104, PRISON EXPERIENCE 3 UNITS

A course which focuses on field trips to various institutions (including Chino Men's Prison and Orange County Main Jail). Follow-up, evaluation and analysis of field trips required.

2210401	7:00-10:10pm	M	Staff	SAC F-103	Full Semester
---------	--------------	---	-------	-----------	---------------

CRIMINAL JUSTICE 105, LEGAL ASPECTS OF EVIDENCE 3 UNITS

Laws and procedural rules of evidence, search and seizure, and judicial review.

2210502	9:30-10:55	MW	Gonis A	SAC A-207	Full Semester
2210501	6:00-9:10pm	T	Williamson M	SAC R-114	Full Semester

CRIMINAL JUSTICE 106, CORONER DEATH INVESTIGATIONS 3 UNITS

An in-depth course on coroner death investigations including the investigation of homicides, suicides, accidents, sexual assaults, and autopsy procedures.

2210601	6:00-9:10pm	Th	Corral F	SAC H-205	Full Semester
---------	-------------	----	----------	-----------	---------------

CRIMINAL JUSTICE 107, PRINCIPLES & PROCEDURES IN THE CRIMINAL JUSTICE SYSTEM 3 UNITS

An in-depth study of the functions and interrelationships of the several agencies of the Criminal Justice system. (Same as Paralegal 107).

2210701	11:30-12:55pm	TTh	Manzano F	SAC A-205	Full Semester
2210702	7:00-10:10pm	T	Alexander R	SAC R-117	Full Semester

CRIMINAL JUSTICE 108, CRIME SCENE INVESTIGATION 3 UNITS

An in-depth course on the collection and preservation of evidence at the crime scene. Includes: Fingerprinting, Arson, Tool Marks, Ballistics, D.N.A. Toxicology, Photography and Sketching.

2210802	8:00-9:25	MW	Jackson G	SAC H-207	Full Semester
2210801	6:00-9:10pm	M	Jackson G	SAC H-207	Full Semester

CRIMINAL JUSTICE 109, COMMUNITY INTERACTION 3 UNITS

Explores roles of Criminal Justice practitioners and how they are perceived by the public with an emphasis on critical thinking and decision making.

2210901	6:00-9:10pm	W	Bell T	SAC H-205	Full Semester
---------	-------------	---	--------	-----------	---------------

CRIMINAL JUSTICE 198, VOLUNTEER INTERNSHIP ACADEMY 3 UNITS

Students will gain an in-depth understanding of the Orange County Probation Department and the possibilities of a career with that agency or in a related field. (Background check required) Prerequisite: Full background check required.

2219801	6:00-9:10pm	W	Pettinicchio D	OCPD	Full Semester
---------	-------------	---	----------------	------	---------------

CRIMINAL JUSTICE 198, SUPERVISED INTERNSHIP WORK EXPERIENCE 1-3 UNITS

Students will be required to work under supervision of The Orange County Probation Department. Grade: CR/NCR only. Prerequisite: CJ 198 Volunteer Internship Academy.

2219802	Hrs Arr		Pettinicchio D	OCPD	Full Semester
---------	---------	--	----------------	------	---------------

(Tckt No 2219802 has one mandatory orientation meeting Mon, Feb 11, 6-8pm at the Orange County Probation Department)

TKT#	TIME	DAYS	INSTRUCTOR	LOC./RM.	DATES
------	------	------	------------	----------	-------

CRIMINAL JUSTICE 205, CRIMINAL INVESTIGATION PRINCIPLES 3 UNITS

Crime scene recording and search; evidence collection and sources of information. Heavy emphasis on report writing.

2220501	8:30-9:55	TTh	Gonis A	SAC H-207	Full Semester
---------	-----------	-----	---------	-----------	---------------

CRIMINAL JUSTICE 209, ORGANIZED CRIME 3 UNITS

International organized crime and its impact on organized crime, white collar crime and political corruption in the United States.

2220902	11:30-12:55pm	TTh	Wright G	SAC H-207	Full Semester
---------	---------------	-----	----------	-----------	---------------

CRIMINAL JUSTICE 220, JUVENILE DELINQUENCY & CONTROL 3 UNITS

Techniques of handling juvenile offenders and victims; diagnosis and referral.

2222002	6:00-9:10pm	Th	Jenkins M	SAC B-9	Full Semester
---------	-------------	----	-----------	---------	---------------

CRIMINAL JUSTICE ACADEMIES

CRIMINAL JUSTICE ACADEMIES 010, PRE-EMPLOYMENT PREPARATION FOR LAW ENFORCEMENT 1 UNIT

Prepares students to successfully complete law enforcement pre-employment testing including oral boards, physical agility, and training requirements. Grade: CR/NCR only.

2301039	6:00-10:00pm	TTh	Troxcil G	OCST	2/26-3/22
AND	7:00am-11:00	S	Neumeister R	OCST	
(class location: Orange County Sheriff's Regional Training Academy: 1900 W. Katella Avenue, Orange, 92867)					
2301040	6:00-10:00pm	TTh	Troxcil G	OCST	5/6-5/31
AND	7:00am-11:00	S	Neumeister R	OCST	

CRIMINAL JUSTICE ACADEMIES 010A, PHYSICAL FITNESS FOR PEACE OFFICER 0.2 UNITS

Specific conditioning & exercise prepare student for Basic Police Academy, and a career in law enforcement. Students will perform physical exercise in the weight room, obstacle course, walls, and various cardiovascular modalities. Proper body mechanics, lifting techniques and physical conditioning principles will be applied. May be repeated. Grade: CR/NCR only.

2301003	6:00-8:00pm	TTh	Bartlett M	CJTC	1/22-2/14
---------	-------------	-----	------------	------	-----------

(Class location; Orange County Sheriff's Regional Training Academy, 15991 Armstrong Ave. Tustin 92782)

CRIMINAL JUSTICE ACADEMIES 021, P.C. 832, LAWS OF ARREST 1 UNIT

This course of instruction will provide the student with a basic knowledge of law enforcement. The course will cover history of law enforcement, arrest, and search and seizure laws. The course is P.O.S.T. certified. May be repeated. Grade: CR/NCR only.

2302154	6:00-10:00pm	TWTh	Troxcil G	OCST	2/5-2/27
---------	--------------	------	-----------	------	----------

(class location: Orange County Sheriff's Regional Training Academy: 1900 W. Katella Avenue, Orange, 92867)

2302155	6:00-10:00pm	TWTh	Troxcil G	OCST	4/22-5/15
---------	--------------	------	-----------	------	-----------

CRIMINAL JUSTICE ACADEMIES 021A, PC 832 FIREARMS 0.5 UNITS

This course of instruction will provide the student with a basic knowledge of firearms, as well as related safety and liability issues. The course is P.O.S.T. certified and presented in cooperation with the Orange County Sheriff's. May be repeated. Grade: CR/NCR only.

2302167	6:00-10:00pm	TWTh	Troxcil G	OCST	3/18-3/27
---------	--------------	------	-----------	------	-----------

(class location: Orange County Sheriff's Training Facility; 1900 W. Katella Avenue, Orange.) DOJ clearance letters and \$35 range fee will be collected the first high of class. * fees may change with out prior notice. *)

2302168	6:00-10:00pm	TWTh	Troxcil G	OCST	5/20-5/29
---------	--------------	------	-----------	------	-----------

CRIMINAL JUSTICE ACADEMIES 041, TRAINING ACADEMY PREPARATION 0.2 UNITS

This course is designed to prepare the student for the Basic Law Enforcement Academy, Criminal Justice Academies 100. It will include: drill, ceremony, physical training, reporting and speeches. May be repeated. Grade: CR/NCR only.

2304143	7:00am-4:00pm	S	Troxcil G	CJTC	2/2-2/9
---------	---------------	---	-----------	------	---------

(Class location: Orange County Sheriff's Regional Training Academy, 15991 Armstrong Avenue, Tustin 92782)

2304144	7:00am-4:00pm	S	Troxcil G	CJTC	4/5-4/12
---------	---------------	---	-----------	------	----------

(Class location: Orange County Sheriff's Regional Training Academy, 15991 Armstrong Avenue, Tustin 92782. Physical attire required.)

FIRST CLASS MEETING

Make sure you attend the first class meeting!
Attendance at the first meeting of a class is advised because of enrollment demands. Any student not reporting to the first class meeting may be dropped from the roll sheet.

CRIMINAL JUSTICE ACADEMIES PROGRAMS

Any questions pertaining to the listed Criminal Justice Programs can be answered by calling the phone number listed by each program title or by calling the Criminal Justice Academies Office at (714) 566-9200. To insure open enrollment, class availability and scheduling flexibility while meeting the training needs of Law Enforcement and other public safety agencies, classes are scheduled on an as-needed basis. It is important that you call for exact class times and dates. Please note that many of the classes listed have a prerequisite requirement.

Basic Police Academy

CJA: 100 984 hrs–24 Units

Prerequisite: Criminal Justice 010 and Admission to the course through Criminal Justice Academies office

Call CJA – 714/566-9200

- Student will receive instruction in all areas of Criminal Justice as Required by P.O.S.T.
- For entry-level law enforcement officers.
- This course is offered in cooperation with the Orange County Sheriff's Department.
- Advisory Reading: 3

Range Training

Prerequisite: CJA 100 or Level III Reserve

Call CJA – 714/566-9200

- 12 Gauge Less-Lethal Munitions
- Advanced Handgun Skills
- Field Tactics Shotgun–4 hr
- Handgun skills and Knowledge–4 hr
- Immediate Action/Rapid Deployment–8 hr
- Laser Firearms–8 hr
- Low Light Shotgun–24 hr
- Motorcycle Tactics Update–10 hr
- Patrol Rifle–40 hr
- Police Carbine–8 hr
- Shotgun–8 hr
- Special Weapons/Tactics Team–16 hr
- Tactical Covert/Crisis Entry–16 hr
- Tactical Firearms–8 hr
- Tactics for Survival–24 hr

Arrest and Control Training

Prerequisite: CJA 100 or Level III Reserve

Call CJA – 714/566-9200

- Arrest & Control Update–8 & 4 hr
- Training the Trainer/Instructor Course–40 hr

Training for Custody Officers

Prerequisite:

Must be Employed in Law Enforcement

Call CJA – 714/566-9200

- Custody/Corrections Update–8hr
- Jail Security for Records Clerks–8 hr
- Sheriff's Special Officer–144 hr

Reserve Training

Prerequisite: Please see each class

Call CJA – 714/566-9200

- Level III Reserve–180 hours
- Level II Reserve–240 hours
(Prerequisite: Level III Reserve)

Leadership Training

Prerequisite: CJA 100 or Level III Reserve

Call CJA – 714/566-9200

- Leadership & Mentoring–40 hr
- Supervision–80 hr
- Supervisory–24 hr

Investigations

Prerequisite: CJA 100 or Level III Reserve

Call CJA – 714/566-9200

- Investigations–24 hr
- Child Sexual Assaults–8hr
- Designer/Rave Drugs–4 hr
- Drug Abuse Recognition & Alcohol Workshop–24 hr
- Drug Identification–4 hr
- D.R.E. recertification–8 hr
- Gang Awareness–24 hr
- 11550 H&S–24 hr
- Homicide–40 hr
- Child Abuse 1st Responder–8 hr
- Narcotics Investigation–80 hr
- Narcotic Search Warrants–8 hr
- Narcotics Update–4 hr
- Occult Crimes–8 hr
- Sex Crimes–4 hr
- Use of Informants–4 hr
- Undercover Operations–8 hr

Advanced Officer Training

Prerequisite: CJA 100 or Level III Reserve

Call CJA – 714/566-9200

- Clan Lab First Responder–16 hr
- Destruction–8 hr
- Domestic Violence–4 hr
- F.T.O.–40 hr
- Mobil Field Force–16 hr
- Officer Safety–24 hr
- Parolee Contacts–4 hr
- Patrol/Police–24 hr
- Police Ethics–4 hr
- Report Writing–24 hr
- Report Writing–4 & 8 hr
- Satanic Cults–8 hr
- Street Gangs–4 hr
- Tactical Communications–4 hr
- Weapons of Mass Destruction–8 hr
- Racial Profiling–8 hr

Driving Simulator

Prerequisite: CJA 100 or Level III Reserve

Call CJA – 714/566-9200

- Driving/Force Option Simulator–8 hr

Miscellaneous Training

Prerequisite: CJA 100 or Level III Reserve

Call CJA – 714/566-9200

- Advanced Mounted–40 hr
- Basic Bike Patrol–24 hr
- CPR/First Aid–8 hr
- Field Tactics Mounted–8 hr
- Haz-Mat First Responder–8 hr
- Hazardous Devices–8-40 hr
- Mounted Update–16 hr
- Narcotic K-9–24 hr
- PO Update Harbor & Beaches–16 hr
- Swift water rescue–4 hr
- Requalification–136 hr

TKT#	TIME	DAYS	INSTRUCTOR	LOC./RM.	DATES
------	------	------	------------	----------	-------

DANCE

DANCE 009, DANCE CLASS LABORATORY **0.5-1.5 UNITS**
 Studio rehearsal time to work out dance class assignments and rehearse for concert performances. Different material each semester. 24 hrs earns 0.5 unit; 48 hrs = 1 unit; 72 hrs = 1.5 units. Open entry/open exit. May be repeated. Grade: CR/NCR only. Prerequisite: Concurrent enrollment in any dance class.

2400901	4.5 Hrs Arr		Kikawa E	SAC G-108	Full Semester
---------	-------------	--	----------	-----------	---------------

Dance 020 will emphasize Pilates techniques for body and dance conditioning. Students will learn floor work and use Pilates equipment.

DANCE 020, CONDITIONING FOR DANCE TECHNIQUES **0.5 UNITS**
 Develops flexibility, coordination, strength for dance techniques, stretching, information on physiology of conditioning for dance. Introduces Pilates and other conditioning techniques applicable to dance. May be repeated. Grade: CR/NCR only.

W 2402002	9:00-9:55	S	Garcia R	SAC G-108	Full Semester
-----------	-----------	---	----------	-----------	---------------

DANCE 022, DANCE STRETCH **0.5 UNITS**
 Instruction in sustained and specific stretching exercises designed to improve overall body flexibility and range of motion. *Of special interest to dancers and athletes. May be repeated. Grade: CR/NCR only.

2402201	8:00-8:55	TTh	Kikawa E	SAC G-108	2/12-4/3
2402203	8:00-8:55	TTh	Kikawa E	SAC G-108	4/15-6/5

This course fulfills the General Education Requirement in the Arts (C1) for the California State Universities and IGETC (Area 3, Group A). It also fulfills the General Education Requirement in Humanities (Plan A, Area C) for the A.A. Degree.

DANCE 100, DANCE HISTORY AND APPRECIATION **3 UNITS**
 The development of dance in Western Europe and the United States from ancient times to the present. Explores dance as an emerging art form from the 15th through the 20th century.

2410001	11:30-12:55pm	TTh	Haddad M	SAC A-130	Full Semester
---------	---------------	-----	----------	-----------	---------------

DANCE 105, WORLD DANCE AND CULTURES **3 UNITS**
 Dance around the world is studied in its cultural/social context. Emphasis is on different ways dance is used to express ideas about religion, cultural identity, myths and social ideals. Includes cultures from Africa, Asia, Europe, India, Latin America, Middle East, and North America, plus a focus on Southern California. Use of live and videotaped performances.

2410501	9:30-10:55	TTh	Kikawa E	SAC A-210	Full Semester
---------	------------	-----	----------	-----------	---------------

DANCE 106A, INTRODUCTION TO MODERN DANCE **1 UNIT**
 An introduction to basic modern dance emphasizing movement technique, dance vocabulary and creative individual expression. Includes an introduction to choreographic principles and cultural context of modern dance. For the student with little or no dance experience. May be repeated.

2410601	11:00-12:55pm	M	Gillette H	SAC G-108	Full Semester
---------	---------------	---	------------	-----------	---------------

DANCE 107, DANCE CONCERT PERFORMANCE **1 UNIT**
 Formal Dance Concert performance experience for dance students. Includes both rehearsal process and a minimum of three on-stage public performances. 48 hours earns one unit. Repertoire and casting vary each semester. May be repeated. Grade: CR/NCR only. Prerequisite: Audition.

2410701	3:30-5:25pm	F	Kikawa E	SAC G-108	Full Semester
---------	-------------	---	----------	-----------	---------------

TKT#	TIME	DAYS	INSTRUCTOR	LOC./RM.	DATES
------	------	------	------------	----------	-------

New Location for Salsa, Folklorico and Caribbean Dance Classes

Wednesdays

DNCE 123 Introduction to Salsa 5:00-7:15 p.m.
 DNCE 124 Intermediate Salsa 7:15-9:20 p.m.

Thursdays

DNCE 110 Beginning Folklorico 7:15-9:15 p.m.
 DNCE 111 Intermediate Folklorico 8:15-10:20 p.m.
 DNCE 298 Special Studies 8:15-10:20 p.m.
 DNCE 118 Intro to Caribbean & Latin Dance Styles 5:30-7:35 p.m.

Room: SAC CDC-100

Child Development Center Multipurpose Room Building is at the corner of 15th St and College Ave, across from the track.

Parking is available in lot adjacent to the building.

DANCE 109, PILATES CONDITIONING **0.5 UNITS**
 Using exercises designed by Joseph Pilates, students develop strength, stability, coordination and control in the core muscles of the body. Applicable for dance, sports and general conditioning. May be repeated. Grade: CR/NCR only.

2410901	7:00am-7:55	TTh	Kikawa E	SAC G-108	2/12-4/3
2410902	7:00am-7:55	TTh	Kikawa E	SAC G-108	4/15-5/29
2410904	5:30-6:25pm	MW	Dance Staff	SAC W-106	4/14-6/4
2410903	5:30-6:45pm	MW	Dance Staff	SAC W-106	2/20-4/2

DANCE 110, BEGINNING MEXICAN FOLK DANCE **1 UNIT**
 Introduces techniques, forms, and regional/historical backgrounds of dances from various regions of Mexico. Students will perform at least 3 different traditional dances. May be repeated.

2411001	7:15-9:15pm	Th	Holguin G	CDC 100	Full Semester
---------	-------------	----	-----------	---------	---------------

DANCE 111, INTERMEDIATE MEXICAN FOLK DANCE **1 UNIT**
 Continued study of techniques, forms and regional/historical backgrounds of Mexican dances. Performance of at least 3 complex traditional dances: solo, duo or group. Dance 110 recommended. May be repeated.

2411101	8:15-10:20pm	Th	Holguin G	CDC 100	Full Semester
---------	--------------	----	-----------	---------	---------------

DANCE 113A, FLAMENCO DANCE I **1 UNIT**
 Introduction to the dance movements, techniques, and terminology of Flamenco dance, music, rhythms, and song. Emphasis on dance skills and cultural relationships between Spain and the Gypsies. May be repeated.

W 2411303	10:00-11:55	Su	Chavez R	SAC G-108	Full Semester
-----------	-------------	----	----------	-----------	---------------

DANCE 113B, FLAMENCO DANCE II **1 UNIT**
 Continued study of Flamenco culture through dance, music and song, with emphasis on particular rhythms. Students will explore the dynamics and structure of these rhythms and learn a choreographed dance. May be repeated. Prerequisite: Dance 113A.

W 2411323	11:00-12:55pm	Su	Chavez R	SAC G-108	Full Semester
-----------	---------------	----	----------	-----------	---------------

DANCE 115A, INTRODUCTION TO TAP DANCE **1 UNIT**
 Introduction to basic tap dance technique. Focuses on the mastery of basic tap steps and simple dance combinations. Recommended for theatre and dance majors. Dance 115A prepares the student for Dance 115B. May be repeated.

2411503	10:00-11:55	F	Millard M	SAC G-108	Full Semester
---------	-------------	---	-----------	-----------	---------------

DANCE 115B, INTRODUCTION TO TAP DANCE **1 UNIT**
 Continued study in tap dance and basic skills necessary for execution of traditional tap dance steps and sequences. Emphasizes mastery of basic steps leading to combination work in complete dances. Recommended for theatre and dance majors. Dance 115A recommended. May be repeated.

2411533	10:00-11:55	F	Millard M	SAC G-108	Full Semester
---------	-------------	---	-----------	-----------	---------------

DANCE 116, INTRODUCTION TO INTERMEDIATE TAP STYLES **1 UNIT**
 Instruction in intermediate level tap dance, emphasizing varied styles including: rhythm tap, musical theatre technique, and traditional styles. Personal skills are refined through the acquisition of intermediate level tap steps and combinations. Repertoire varies every semester. May be repeated.

2411633	10:00-11:55	F	Millard M	SAC G-108	Full Semester
---------	-------------	---	-----------	-----------	---------------

DANCE 117, INTRODUCTION TO MIDDLE EASTERN DANCE **1 UNIT**
 Introduction to Middle Eastern Dance, including belly dance and folk dance forms. Emphasis is on movement technique, vocabulary and creative expression. Also explores the fusion of Western and Middle Eastern dance forms. No experience necessary. Content varies each semester. May be repeated.

2411701	7:00-9:05pm	M	Larsen J	SAC G-108	Full Semester
---------	-------------	---	----------	-----------	---------------

World Dance and Cultures

Dance 105



Ever thought about the dancing people do at weddings, high school proms or in parades? It's all part of the way dance expresses culture. Dance 105 is a lecture course that looks at the use of dance around the world in rituals and ceremonies, and how it impacts our lives. Course includes videotaped performances and fulfills the General Education requirement in Arts (C1) for the California State Universities and IGETC (Area 3, Group A). It also fulfills the General Education requirement in Humanities (Plan A, Area C) for the A.A. degree.

TKT#	TIME	DAYS	INSTRUCTOR	LOC./RM.	DATES
DANCE 118, INTRODUCTION TO CARIBBEAN AND LATIN DANCE STYLES 1 UNIT					
An introduction to Caribbean and Latin social dance styles, including musicality, partnering and patterns. Emphasis is on movement technique, vocabulary and creative expression. Historical and contemporary forms such as merengue, rumba, cumbia and tango are studied. Content varies each semester. May be repeated.					
W 2411801	5:30-7:35pm	F	Figueroa, Jr. M	CDC 100	Full Semester
DANCE 119A, INTRODUCTION TO JAZZ DANCE 1 UNIT					
Introduction to jazz dance technique emphasizing elementary movement technique, vocabulary and creative expression. Includes an introduction to composition and cultural context of jazz. For students with little or no dance experience. May be repeated.					
W 2411902	10:00-11:55	S	Jensen K	SAC G-108	Full Semester
2411904	1:00-2:55pm	M	Gillette H	SAC G-108	Full Semester
DANCE 119B, INTRODUCTION TO JAZZ DANCE 1 UNIT					
A refinement of basic jazz dance, emphasizing movement technique, vocabulary and creative expression. Includes composition, the cultural context of jazz and contemporary jazz dance forms. Movement repertoire differs from 119A. May be repeated.					
W 2411922	10:00-11:55	S	Jensen K	SAC G-108	Full Semester
DANCE 120, INTRODUCTION TO URBAN JAZZ DANCE:HIP-HOP 1 UNIT					
An introduction to Hip-Hop dance emphasizing movement technique, dance vocabulary and creative expression. Includes learning routines and the history and culture of Hip-Hop dance. No prior experience necessary. May be repeated.					
2412001	3:00-4:55pm	Th	Jensen K	SAC G-108	Full Semester
DANCE 121, INTERMEDIATE URBAN JAZZ DANCE HIP-HOP 1 UNIT					
A continuation of the study of hip-hop dance emphasizing movement technique, dance vocabulary and creative expression. Includes more complicated movements, advanced dance combinations and an overview of the historical and cultural context of hip-hop. Beginning Hip-Hop recommended. May be repeated.					
2412101	7:15-9:20pm	T	Jensen K	SAC G-108	Full Semester
DANCE 123, INTRODUCTION TO SALSA DANCE 1 UNIT					
An introduction to Salsa Dance, including musicality, partnering and patterns. Emphasis is on movement technique, dance vocabulary and creative expression. Historical and contemporary forms are studied. Content varies each semester. May be repeated.					
2412301	5:00-7:15pm	W	Figueroa, Jr. M	CDC 100	Full Semester
DANCE 124, INTERMEDIATE SALSA DANCE 1 UNIT					
Continued study in salsa dance, including musicality, partnering and patterns. Emphasis is on movement technique, vocabulary and expression. Includes more complicated movements, complex patterns and advanced dance combinations. Content varies each semester. Introduction to salsa recommended. May be repeated.					
2412401	7:15-9:20pm	W	Figueroa, Jr. M	CDC 100	Full Semester
DANCE 201A, BALLET I 2 UNITS					
Introduction to ballet technique including instruction in alignment, basic barre and center work, and ballet terminology. For the student with little or no dance experience. Prepares the student for 201B.					
2420101	9:30-10:55	MW	Garcia R	SAC G-108	Full Semester
AND	1 Hr Arr		Garcia R	SAC G-108	
DANCE 201B, BALLET II 2 UNITS					
Additional instruction in alignment, basic barre and center work and ballet terminology. Prepares the student for Dance 213. Dance 201A recommended.					
2420131	9:30-10:55	MW	Garcia R	SAC G-108	Full Semester
AND	1 Hr Arr		Garcia R	SAC G-108	
DANCE 204A, DANCE PRODUCTION 3 UNITS					
For students interested in performing in the SAC dance concert. Includes production basics, with an emphasis on working with faculty/student choreographers on original dances. Prerequisite: Audition.					
2420401	1:10-2:55pm	TTh	Gillette H	SAC G-108	Full Semester
DANCE 204B, DANCE PRODUCTION 3 UNITS					
For students interested in producing original choreography for and/or performing in the SAC dance concert. Includes production basics with emphasis on creating, rehearsing and performing dances. Prerequisite: Dance 202A or 202B and Audition.					
2420402	1:10-2:55pm	TTh	Dance Staff	SAC G-108	Full Semester
AND	3.5 Hrs Arr		Dance Staff	SAC G-108	
DANCE 205, PERFORMANCE ENSEMBLE 2-4 UNITS					
Pre-professional ensemble to provide performance experience for advanced students. 64 hours earns 2 units; 112 hours earns 3 units; 160 hours earns 4 units. Repertoire and casting vary each semester. May be repeated. Grade: CR/NCR only. Prerequisite: Audition.					
2420501	3:00-4:40pm	MW	Kikawa E	SAC G-108	Full Semester
DANCE 206A, MODERN DANCE I 2 UNITS					
An introduction to modern dance, emphasizing movement technique, dance vocabulary and creative individual expression. Includes an introduction to choreographic principles and cultural context of modern dance. For those with little or no dance experience. Prepares the student for Dance 206B. May be repeated.					
2420601	11:00-12:55pm	MW	Gillette H	SAC G-108	Full Semester

TKT#	TIME	DAYS	INSTRUCTOR	LOC./RM.	DATES
Dance Auditions					
Dance Production Dance 107, 204, 205 25-30 dancers are needed. Auditions for the Faculty Dance Concert: Thursday, February 14, 2008 1:00-2:30 pm and 5:00-6:30 pm, Santa Ana College Room G-108. Attend one session only.					
Audition is required before enrolling in Dance 107, 240, or 205. For information call the Dance Department, 714-564-5641.					
DANCE 206B, MODERN DANCE II 2 UNITS					
Continued study in modern dance emphasizing movement technique, dance vocabulary and creative individual expression. Includes choreographic principles and cultural context of modern dance. Movement repertoire differs from Dance 206A. May be repeated. Prerequisite: Dance 206A or audition.					
2420602	11:00-1:05pm	TTh	Gillette H	SAC G-108	Full Semester
DANCE 209, MODERN DANCE III 2 UNITS					
Allows the continuing modern dance student to develop further skills in modern dance technique. Emphasizes combinations and performance. Dance 206 recommended.					
2420902	11:00-1:05pm	TTh	Gillette H	SAC G-108	Full Semester
DANCE 210, MODERN DANCE IV 2 UNITS					
Continuing study of technique with more advanced material. Emphasizes movement, expression, composition techniques, and comparison of modern dance styles. Dance 209 recommended.					
2421002	11:00-1:05pm	TTh	Gillette H	SAC G-108	Full Semester
DANCE 213, BALLET 111 2 UNITS					
Study of ballet technique and terminology on the intermediate level. Course content includes center adagio, training in jumps, pirouettes and movement combinations. Dance 201AB recommended prior to enrolling. May be repeated.					
2421301	9:30-10:55	TTh	Perez M	SAC G-108	Full Semester
AND	1 Hr Arr		Perez M	SAC G-108	
DANCE 214, BALLET IV 2 UNITS					
Study of high intermediate technique and terminology. Stresses expression and style and more intricate allegro steps, pirouettes, and movement combinations. Includes style comparisons and some dance history. Dance 213 is recommended. May be repeated.					
2421401	9:30-10:55	TTh	Perez M	SAC G-108	Full Semester
AND	1 Hr Arr		Perez M	SAC G-108	
DANCE 219A, JAZZ DANCE I 2 UNITS					
Introduction to jazz dance emphasizing movement technique, vocabulary, and creative expression. Includes an introduction to choreographic principles and cultural context of jazz. Historical and contemporary forms are studied. Designed for those with little or no dance experience. May be repeated.					
2421901	1:00-2:55pm	MW	Gillette H	SAC G-108	Full Semester
DANCE 219B, JAZZ DANCE II 2 UNITS					
Continued study in jazz dance emphasizing movement technique, vocabulary and creative expression. Includes an introduction to choreographic principles and cultural context of jazz. Historical and contemporary forms are studied. Movement repertoire differs from 219A. May be repeated.					
2421921	1:00-2:55pm	MW	Gillette H	SAC G-108	Full Semester
2421902	5:00-7:05pm	TTh	Jensen K	SAC G-108	Full Semester
DANCE 220, JAZZ DANCE III 2 UNITS					
Instruction for the continuing jazz dance student in intermediate jazz steps and further development of technical skills. Emphasis will be placed on combinations, choreography, performance style and cultural context of jazz. Historical and contemporary forms are studied. Dance 219B recommended.					
2422001	5:00-7:05pm	TTh	Jensen K	SAC G-108	Full Semester
DANCE 221, JAZZ DANCE IV 2 UNITS					
Continuing study of jazz techniques concentrating on advanced combinations with emphasis on movement technique, vocabulary and performance style. Includes study of choreography, cultural context of jazz and comparisons of historical and contemporary jazz styles. Dance 220 recommended.					
2422101	5:00-7:05pm	TTh	Jensen K	SAC G-108	Full Semester

TKT#	TIME	DAYS	INSTRUCTOR	LOC./RM.	DATES
DANCE 296, SPECIAL STUDIES IN MODERN DANCE 1 UNIT					
An intermediate/advanced level course offering accelerated, individual instruction in modern dance techniques. May be repeated. Grade: CR/NCR only. Prerequisite: Completion of two dance classes in modern dance.					
2429601	11:00-1:05pm	T	Gillette H	SAC G-108	Full Semester
DANCE 297, SPECIAL STUDIES IN JAZZ DANCE 1 UNIT					
An intermediate/advanced level course offering accelerated, individual instruction in jazz dance techniques. May be repeated. Grade: CR/NCR only. Prerequisite: Completion of two dance classes in jazz dance.					
2429701	5:00-7:05pm	T	Jensen K	SAC G-108	Full Semester
DANCE 298, SPECIAL STUDIES IN DANCE 1 UNIT					
An intermediate/advanced level course offering accelerated, individual instruction in dance techniques. May be repeated. Grade: CR/NCR only. Prerequisite: Completion of two dance classes in ballet, jazz or modern dance.					
2429822	9:30-10:25	TTh	Perez M	SAC G-108	Full Semester
W 2429804	11:00-12:55pm	Su	Chavez R	SAC G-108	Full Semester
2429803	8:15-10:20pm	Th	Holguin G	CDC 100	Full Semester

DATA PROCESSING
(SEE BUSINESS APPLICATIONS/COMPUTER SCIENCE)

DIESEL

DIESEL 008, OXYACETYLENE-ARC WELDING 3 UNITS					
Technical knowledge and basic skills needed for occupational oxyacetylene and arc welding processes and applications. Students must furnish safety equipment. (Same as Automotive Technology 008 and Welding 008.)					
\$25.00 material fee required for this course at registration.					
2500802	8:00-11:10	TTh	Moreno G	SAC K-101	Full Semester
2500804	6:00-9:10pm	MW	Moreno G	SAC K-101	Full Semester
2500803	6:00-9:10pm	TTh	Moreno G	SAC K-101	Full Semester
DIESEL 013, ALLISON TRANSMISSION SERVICE 5 UNITS					
A course of study designed to familiarize the student with the operation, service, overhaul, and troubleshooting procedures of Allison transmissions. Students must furnish hand tools and safety equipment. May be repeated.					
2501301	6:30-10:45pm	TTh	Staff	SAC B-32	Full Semester
DIESEL 021, MID-RANGE DIESEL ENGINE SERVICE 5 UNITS					
Prepares students with vocational knowledge and skills related to medium duty diesel engines and fuel systems. Students must furnish own safety equipment.					
2502101	6:30-10:45pm	MW	Hogue T	SAC J-101	Full Semester
DIESEL 050, TRANSPORT REFRIGERATION 8 UNITS					
Theory of operation, service, repair, and troubleshooting of refrigeration, electrical systems and microprocessor control systems used on Thermo-King and Carrier Transport truck and trailer transport refrigeration units.					
2505001	8:00-12:15pm	TWTh	Hogue T	SAC B-32	Full Semester
DIESEL 095, DIESEL LAB EXPERIENCE 0.5-4 UNITS					
Lab experience in advanced diesel courses. Students furnish hand tools and safety equipment. (Same as Automotive Technology 095.) Open entry/open exit. Grade: CR/NCR only. Prerequisite: Completion of corresponding Diesel course with a grade of C or better.					
2509501	Hrs Arr		Hogue T	SAC B-32	Full Semester

DIESEL TRANSIT COURSES

For details on times, dates and registration, contact the Diesel Technology Office at 714-564-6800.

- DSL 068 Transit Vehicle Engines
- DSL 069 Paratransit Driver Training
- DSL 070 Bus Driver Training
- DSL 071 Introduction to Coach Operations
- DSL 072 Transit Vehicle Electrical Systems
- DSL 073 Transit Vehicle Air Systems
- DSL 075 Transit Vehicle Automatic Transmissions
- DSL 077 Transit Vehicle Heating, Ventilation, Air Conditioning
- DSL 078 Transit Vehicle Drive Train Suspension
- DSL 079 Transit Vehicle Wheelchair Lifts
- DSL 080 Transit Vehicle Air Brake Systems

TKT#	TIME	DAYS	INSTRUCTOR	LOC./RM.	DATES
DRAMA (SEE THEATRE ARTS)					
EARTH SCIENCE					
EARTH SCIENCE 110, INTRODUCTION TO EARTH SCIENCE 3 UNITS					
A study of the processes that shape and form the Earth and define its place in the solar system. Introduction to the sciences of geology, oceanography, meteorology and astronomy. Not open to students who have taken, or are taking Geology 101 or Geography 101.					
2711010	8:00-9:25	MW	Sci Staff	SAC R-111	Full Semester
2711002	8:00-9:25	TTh	Coyne C	SAC R-111	Full Semester
W 2711004	9:00-12:10pm	S	Greenwood R	SAC R-111	Full Semester
2711013	9:30-12:35pm	F	Wareham S	SAC R-126	Full Semester
2711011	11:30-12:55pm	MW	Hughes P	SAC R-111	Full Semester
2711005	11:30-12:55pm	TTh	Hughes P	SAC R-111	Full Semester
2711009	6:30-9:50pm	MTWTh	Sci Staff	SAC R-111	1/7-1/31
2711001	7:00-10:10pm	MW	Sci Staff	SAC R-126	4/14-6/4
2711008	7:00-10:10pm	T	Sci Staff	SAC R-128	Full Semester

EARTH SCIENCE 110H, HONORS INTRODUCTION TO EARTH SCIENCE 3 UNITS					
An intensive study of the processes that shape and form the Earth and define its place in the solar system. Introduction to the sciences of geology, oceanography, meteorology, and astronomy. Not open to students who are enrolled, or have credit in Geology 101 or Geography 101. Prerequisite: A high school or college GPA of 3.0 or above.					
2711014	1:30-4:30pm	W	Coyne C	SAC R-111	Full Semester

EARTH SCIENCE 115, EARTH SCIENCE FOR EDUCATORS 4 UNITS					
Study of Earth Science designed for future teachers with an integrated lab and lecture approach. Not open to students who have taken, or are taking Earth Science 110, Geology 101 or Geography 101.					
2711501	9:45-12:55pm	TTh	Coyne C	SAC R-328	Full Semester

COURSES IN OTHER DISCIPLINES RELATED TO EARTH SCIENCE: Geology 101 Introduction to Geology 101L Introduction to Geology Lab, and Geology 140 Environmental Geology

ECONOMICS

ECONOMICS 120, PRINCIPLES/MACRO 3 UNITS					
Introduction economics with emphasis on national and international issues. Recommended as a first course in economics. Mathematics 060 and Speech Communication 097 or Communication 097 are recommended.					
2812016	Hrs Arr		Ho L	SAC WEB	Full Semester
(Tckt No 2812016 combines online and on campus instruction. Mandatory on-campus meetings: Thurs, Feb 14, Fri, Apr 4, May 23, 4:30-5:30pm, SAC D-209. See Online Line Courses page in class schedule or go to www.sac.edu/disted for more information.)					
2812001	8:00-9:25	MW	Montes A	SAC D-209	Full Semester
2812006	9:00-12:35pm	MTWTh	Montes A	SAC D-209	1/8-1/31
2812003	9:45-11:10	MW	Montes A	SAC D-209	Full Semester
2812004	9:45-11:10	TTh	Montes A	SAC D-209	Full Semester
2812007	11:30-12:55pm	TTh	Montes A	SAC D-209	Full Semester
2812014	5:30-8:40pm	TTh	Shah S	SAC D-105	2/12-4/1
W 2812013	6:00-9:10pm	F	Amirfathi P	SAC D-209	2/15-4/5
W 2812012	9:00-12:10pm	S	Amirfathi P	SAC D-209	Full Semester
2812008	7:00-10:10pm	W	Montes A	SAC D-101	Full Semester

ECONOMICS 121, PRINCIPLES/MICRO 3 UNITS					
Introduction to economics with emphasis on individual consumers, firms, markets, industry structures, and resource markets. Economics 120, Mathematics 060 and Speech Communication 097 or Communication 097 are recommended.					
2812111	Hrs Arr		Ho L	SAC WEB	Full Semester
(Tckt No 2812111 combines online and on campus instruction. Mandatory on-campus meetings: Thurs, Feb 14, Fri, Apr 4, May 23, 5:40-6:40pm, SAC D-209. See Online Line Courses page in class schedule or go to www.sac.edu/disted for more information.)					
2812101	8:00-9:25	TTh	Montes A	SAC D-209	Full Semester
2812102	11:30-12:55pm	MW	Montes A	SAC D-209	Full Semester
2812108	5:30-8:40pm	TTh	Shah S	SAC D-105	4/15-6/5
W 2812106	6:00-9:10pm	F	Amirfathi P	SAC D-209	4/18-6/7
W 2812110	9:00-12:10pm	S	Amirfathi P	SAC D-209	Full Semester
2812110	6:00-9:35pm	MTWTh	Montes A	SAC D-209	1/8-1/31
2812104	7:00-10:10pm	Th	Meister D	SAC D-209	Full Semester

STUDENTS: Web access to student records and registration is on its way!
Go to www.sac.edu – click on online records and update your student profile with your personal email address. **We'll be in touch.**

TKT#	TIME	DAYS	INSTRUCTOR	LOC./RM.	DATES
------	------	------	------------	----------	-------

EDUCATION

SEE ALSO HUMAN DEVELOPMENT

EDUCATION 100, INTRODUCTION TO EDUCATION **3 UNITS**

Introduction to the field of education including historical and philosophical perspectives; school governance and funding; societal influences and student diversity; school curriculum standards; professional standards and teaching performance expectations. Two to three additional hours per week will be arranged for field experience in a local school. Minimum of 32 hours total is required.

2910001	6:00-9:10pm	M	Silverman L	SAC B-6	Full Semester
AND	2 Hrs Arr		Silverman L	SAC B-6	

EDUCATION 204, PERSONAL PROFICIENCY IN EDUCATIONAL TECHNOLOGIES FOR SECONDARY TEACHERS **3 UNITS**

Development of personal proficiency in educational technologies to facilitate the teaching process. Training in computer hardware and software terminology; spreadsheets, word processing, publication, and presentation applications; Internet search and retrieval; information literacy; electronic communication and awareness of legal and ethical issues.

2920401	7:00-10:10pm	M	Lehrer C	SAC A-226	Full Semester
AND	1 Hr Arr		Lehrer C	SAC WEB	

(Tckt. No 2920401 will have mandatory meetings Mon, Feb 11, 8:30 to 10pm, Feb 25, Mar 10, 24, Apr 14, 28, May 12, 7-10pm, SAC A-226. See Online Courses page in class schedule or go to www.sac.edu/disted for more information.)

EDUCATION 210, THE TEACHING EXPERIENCE: SECONDARY EDUCATION **3 UNITS**

Introduction to the history, philosophy, and sociology of secondary education. This course will cover the California Teaching Performance Expectations and Assessment; needs of special populations, English learners, and struggling readers; content standards; and major curriculum reform documents. Includes a 40-hour practicum.

2921001	3:45-6:55pm	M	Carrera C	SAC A-207	Full Semester
---------	-------------	---	-----------	-----------	---------------

EMERGENCY MEDICAL TECHNICIAN

EMERGENCY MEDICAL TECHNICIAN 100, EMERGENCY MEDICAL TECHNICIAN I - (BASIC) **6 UNITS**

Basic course for EMT-1 Basic. Satisfies requirements for County/State EMS Authority. Prepares student to take O.C.E.M.S./National Registry certifying exam. Prerequisite: CPR Healthcare Provider Card.

3110001	8:30-12:45pm	TTh	Dethlefsen E	SAC R-307	Full Semester
3110003	12:30-4:45pm	MW	Dethlefsen E	SAC R-307	Full Semester

(Current CPR for HEALTHCARE PROVIDER card required for Tckt No 3110001 and 3110003)

EMERGENCY MEDICAL TECHNICIAN 105, CLINICAL SKILLS LABORATORY **0.5 UNITS**

Supervised use of skill lab to assist the student in development of clinical competency and mastery of psychomotor skills. Hours verified by instructor. May be repeated. Grade: CR/NCR only. Prerequisite: Enrollment in EMT 100.

3110501	8:00-5:05pm	F	Dethlefsen E	SAC R-203	Full Semester
---------	-------------	---	--------------	-----------	---------------

EMERGENCY MEDICAL TECHNICIAN 111, RECERTIFICATION FOR EMT I-BASIC **2 UNITS**

Update of emergency medical techniques. Prerequisite: Valid EMT I (Basic) certificate or equivalent within past four years. Valid CPR card: Health Care Provider.

3111101	9:30-5:05pm	FS	Dethlefsen E	SAC R-307	4/18-4/26
AND	8 Hrs Arr		Dethlefsen E	SAC R-307	

(Current EMT and CPR for HEALTHCARE PROVIDER card are required)

ENERGY (SEE ENVIRONMENTAL STUDIES)

ENGINEERING

ENGINEERING 011, BASIC BLUEPRINT READING **2 UNITS**

Reading and interpreting blueprints for manufacturing. (Same as Manufacturing Technology 011.)

3201101	8:45-10:50	F	Farmer B	SAC A-130	Full Semester
W 3201102	4:45-6:50pm	F	Bartlett R	SAC R-114	Full Semester

ENGINEERING 012, AEC BLUEPRINT READING **2 UNITS**

Reading and interpreting blueprints for Architecture, Civil Engineering, Construction, (AEC). Information in this course provides preparation for more advanced AEC coursework. Recommended for students with no prior course(s) in blueprint reading. May be repeated.

3201203	9:30-12:05pm	TTh	Caldin Sr. R	SAC A-216	Full Semester
3201201	6:00-10:30pm	M	Burgos J	SAC A-216	2/11-3/31

ENGINEERING 103, SOLIDWORKS BASIC SOLID MODELING **3 UNITS**

Creation of solid models and 3D toolpaths using Solidworks software. (Same as Manufacturing Technology 103.) May be repeated.

3210302	6:00-10:10pm	M	Corley G	SAC T-203	Full Semester
AND	1 Hr Arr		Corley G		
3210301	6:00-10:10pm	T	Corley G	SAC T-203	Full Semester
AND	1 Hr Arr		Corley G	SAC T-203	

TKT#	TIME	DAYS	INSTRUCTOR	LOC./RM.	DATES
------	------	------	------------	----------	-------

ENGINEERING 104, SOLIDWORKS INTERMEDIATE SOLID MODELING **3 UNITS**

Creation of solid models and 2D detail drawings using Solidworks software. (Same as Manufacturing Technology 104.) May be repeated. Prerequisite: Manufacturing Technology 083 or Engineering 103.

3210401	6:00-9:10pm	W	Cole J	SAC T-203	Full Semester
AND	2 Hrs Arr		Cole J	SAC T-203	

ENGINEERING 105, SOLIDWORKS ADVANCED SOLID MODELING **3 UNITS**

Advanced solid modeling procedures; use of Photoworks and Animator. (Same as Manufacturing Technology 105.) May be repeated. Prerequisite: Engineering 104.

3210501	6:00-9:10pm	Th	Cole J	SAC T-203	Full Semester
AND	2 Hrs Arr		Cole J	SAC T-203	

ENGINEERING 110, ADVANCED CAD APPLICATIONS **0.5-4 UNITS**

Individual skill development for advanced students desiring to learn special applications using college licensed computer drafting and design software. Each 0.5 unit of credit requires 24 laboratory hours. Suggested preparation: Engineering 184. Open entry/open exit. Grade: CR/NCR only.

\$2.00 material fee required for this course at registration.

3211002	Hrs Arr		Takahashi C	SAC A-225	Full Semester
---------	---------	--	-------------	-----------	---------------

(Orientation Mon, Feb 11, 6pm, SAC A225. Email instructor first week of class.)

ENGINEERING 114, GEOMETRIC DIMENSIONING AND TOLERANCING **3 UNITS**

Drawing interpretation utilizing geometric dimensioning and tolerancing (ANSI Y14.5) as applied in engineering, manufacturing, and inspection. Suggested preparation: Prior or concurrent enrollment in Engineering 011 or 122. (Same as Manufacturing Technology 114.)

3211401	4:00-7:00pm	W	O'Loughlin P	SAC A-214	Full Semester
3211402	7:00-10:10pm	M	Bartlett R	SAC R-114	Full Semester

ENGINEERING 122, ENGINEERING DRAWING **3 UNITS**

Extended review of basic skills of engineering drawing principles. Study of manufacturing processes, projections, intersections and developments, utilizing sketches and computer drafting program. Suggested preparation: Engineering 051 and 183 (Engineering 183 may be taken concurrently).

\$4.00 material fee required for this course at registration.

W 3212203	8:00-1:05pm	S	Babikian A	SAC A-214	Full Semester
W AND	2 Hrs Arr		Staff	SAC A-225	
3212202	7:00-10:10pm	M	Takahashi C	SAC A-214	Full Semester

ENGINEERING 125, ENGINEERING GRAPHICS (CAN ENGR 2) **3 UNITS**

Technical drawing and descriptive geometry fundamentals. Includes projection theory, dimensioning, tolerancing, section, design and graphical mathematics, utilizing sketches and computer drafting program. Suggested preparation: Engineering 183 (may be taken concurrently). Prerequisite: Engineering 051 and Mathematics 160.

\$4.00 material fee required for this course at registration.

3212501	7:00-10:10pm	M	Takahashi C	SAC A-214	Full Semester
---------	--------------	---	-------------	-----------	---------------

ENGINEERING 142, ARCHITECTURE/CIVIL ENGINEERING/CONSTRUCTION (AEC) DRAFTING STANDARDS **4 UNITS**

Basic AEC graphic standards using computer drafting. Topics include plans, elevations, sections, schedules, structures, abbreviations, lettering, symbols and linetypes. Recommended preparation Engineering 012 and 184. Prerequisite: Engineering 183.

\$4.00 material fee required for this course at registration.

3214201	4:00-6:55pm	MW	Safa W	SAC A-225	Full Semester
AND	2 Hrs Arr		Staff	SAC A-225	

(Instructional methods for this class may include use of Internet)

ENGINEERING 148, INTRODUCTION TO MECHANICAL, INDUSTRIAL, ELECTRICAL ENGINEERING **2 UNITS**

Introduction to Mechanical, Industrial, Electrical and related areas of Engineering. Includes an overview of academic programs, career information and preparation requirements, virtual or in person field trips, and guest speakers.

\$2.00 material fee required for this course at registration.

3214803	4:00-6:00pm	Th	Takahashi C	SAC A-214	Full Semester
OR	6:00-10:10pm	Th	Takahashi C	SAC A-214	

(Tckt No 3214803 - Mandatory meeting on Thurs, Feb 15, 6pm, SAC A-225)

3214802	Hrs Arr		Johnson G	SAC WEB	Full Semester
---------	---------	--	-----------	---------	---------------

(Orientation Wed, Feb 13, 7pm, SAC A-225. See Online Courses page in class schedule or go to www.sac.edu/disted for more information. Email instructor first week of class.)

ENGINEERING 149, INTRODUCTION TO ARCHITECTURE/CIVIL ENGINEERING/ CONSTRUCTION (AEC) **2 UNITS**

Introduction to the Architectural, Civil Engineering, Construction (AEC) fields. Includes an overview of academic programs, career information and preparation requirements, virtual or in person field trips, and guest speakers.

\$2.00 material fee required for this course at registration.

3214903	9:30-12:05pm	TTh	Caldin Sr. R	SAC A-216	Full Semester
3214901	4:00-6:00pm	Th	Takahashi C	SAC A-214	Full Semester

OR	6:00-10:10pm	Th	Takahashi C	SAC A-214	
----	--------------	----	-------------	-----------	--

(Tckt No 3214901 - Mandatory meeting Thurs, Feb 15, 6pm, SAC A-225)

3214902	Hrs Arr		Johnson G	SAC WEB	Full Semester
---------	---------	--	-----------	---------	---------------

(Orientation Wed, Feb 13, 7pm, SAC A-225. See Online Courses page in class schedule or go to www.sac.edu/disted for more information. Email instructor first week of class.)

SAC Engineering Program

- Day, Night, Weekend, Online classes
- Certificate/Degree Programs Available
- University Transfer
- Credit by Exam
- Transfer-in Credit
- Outstanding Facilities
- Excellent Faculty
- Strong CAD Vocational Programs/Courses
- New ENGR 205 Civil Digital Computations
- Revised Civil Technology Degree/Certificate



ENGINEERING 183, AUTOCAD I - COMPUTER AIDED DRAFTING 3 UNITS

A first course in computer drafting using AutoCAD software. Topics include: display and file management, units, entities, object selection, advanced editing, layers, dimensions, text, graphic exchange.

\$4.00 material fee required for this course at registration.

(Software Utilized: AutoCad 2007)

W	3218304	9:00-12:00pm	MW	Takahashi C	SAC A-214	Full Semester
	3218307	1:00-2:55pm	S	Fonseca J	SAC A-216	Full Semester
	AND	2 Hrs Arr		Staff	SAC A-225	
	3218303	1:00-3:25pm	TTh	Caldin Sr. R	SAC A-216	Full Semester
	AND	1 Hr Arr		Staff	SAC A-225	
	3218302	6:00-10:10pm	M	Burgos J	SAC A-216	4/14-6/2
	AND	4 Hrs Arr		Staff	SAC A-225	
	3218306	6:00-10:10pm	MTWTh	Iranpour S	SAC A-216	1/7-1/31
	AND	8 Hrs Arr		Staff	SAC A-225	
	3218301	6:00-10:10pm	W	Iranpour S	SAC A-216	Full Semester

ENGINEERING 184, AUTOCAD II - COMPUTER AIDED DRAFTING 3 UNITS

Intermediate course in the use of AutoCAD software. Topics include blocks, hatches, attributes, inquiry, and 3-D introduction. Recommended preparation: Engineering 183.

\$4.00 material fee required for this course at registration.

(Software Utilized: AutoCad 2007)

W	3218408	8:00-12:10pm	S	Fonseca J	SAC A-216	Full Semester
	AND	2 Hrs Arr		Staff	SAC A-225	
	3218406	9:00-12:00pm	MW	Takahashi C	SAC A-214	Full Semester
	3218403	1:00-3:25pm	TTh	Caldin Sr. R	SAC A-216	Full Semester
	AND	1 Hr Arr		Staff	SAC A-225	
	3218405	6:00-10:10pm	MTWTh	Iranpour S	SAC A-216	1/7-1/31
	AND	8 Hrs Arr		Staff	SAC A-225	
	3218401	6:00-10:10pm	W	Iranpour S	SAC A-216	Full Semester
	3218404	6:00-10:10pm	Th	Galvez R	SAC A-216	Full Semester
	AND	2 Hrs Arr		Staff	SAC A-225	

ENGINEERING 185, AUTOCAD III - COMPUTER AIDED DRAFTING 3 UNITS

Advanced course in the use of AutoCAD software. Topics include DXF format, scripts, macros, customizing, and creating image tile menus. Recommended preparation: Engineering 184.

\$4.00 material fee required for this course at registration.

(Software Utilized: AutoCad 2007)

W	3218503	8:00-12:10pm	S	Fonseca J	SAC A-216	Full Semester
	AND	2 Hrs Arr		Staff	SAC A-225	
	3218501	6:00-10:10pm	Th	Galvez R	SAC A-216	Full Semester
	AND	2 Hrs Arr		Staff	SAC A-225	

ENGINEERING 186, AUTOCAD 3-DIMENSIONAL DRAWING 3 UNITS

Use of AutoCAD's 3 dimensional software. Includes: 3-D models, extruding to 3-D, coordinate space, filter, and dynamic viewing.

Recommended preparation: Engineering 184.

\$4.00 material fee required for this course at registration.

(Software Utilized: AutoCad 2007)

	3218602	7:00-10:10pm	W	Galvez R	SAC A-214	Full Semester
	AND	6:00-6:55pm	W	Galvez R	SAC A-225	
	AND	2 Hrs Arr		Staff	SAC A-225	

ENGINEERING 187, ADVANCED 3-D AUTOCAD 3 UNITS

Advanced use of AutoCAD's 3-Dimensional software. Includes: merging of models, advanced modeling calculations, 3-dimensional rendering and presentation. Suggested preparation: Engineering 186.

\$4.00 material fee required for this course at registration.

(Software Utilized: AutoCad 2007)

	3218702	7:00-10:10pm	W	Galvez R	SAC A-214	Full Semester
	AND	6:00-6:55pm	W	Galvez R	SAC A-225	
	AND	2 Hrs Arr		Staff	SAC A-225	

ENGINEERING 188, MACHINE TECHNOLOGY SURVEY 3 UNITS

Fundamentals of machine tool setup and operation including general knowledge of machine tools and processes. For non-Manufacturing Technology majors. Students must furnish safety eye wear and 6-inch steel rule. (Same as Manufacturing Technology 188.) Prerequisite: Successful completion or concurrent enrollment in Engineering 011, 051; Manufacturing Technology 011; or Automotive Technology 002 or 006.

	3218801	9:00-1:15pm	TTh	Kanzler D	SAC T-107	Full Semester
	3218802	5:30-9:45pm	TTh	Gershman B	SAC T-107	Full Semester

ENGINEERING 191, CIVIL CAD CONCEPTS 3 UNITS

Fundamental principles and operation of the Intergraph MicroStation computer aided drafting and design system emphasizing Civil Engineering applications, to create, modify, store and plot graphic data.

\$4.00 material fee required for this course at registration.

(Software Utilized: MicroStation V8XM)

	3219101	6:00-10:10pm	T	Iranpour S	SAC A-216	Full Semester
	AND	2 Hrs Arr		Staff	SAC A-225	

ENGINEERING 193, MICROSTATION 3-D 3 UNITS

Theory, concepts, techniques and practices of three dimensional design using Intergraph MicroStation. Topics include surfaces, solids, shade, and color. Suggested preparation: Engineering 191.

\$4.00 material fee required for this course at registration.

(Software Utilized: MicroStation V8XM)

	3219301	6:00-10:10pm	T	Iranpour S	SAC A-216	Full Semester
	AND	2 Hrs Arr		Staff	SAC A-225	

ENGINEERING 228, DESCRIPTIVE GEOMETRY 3 UNITS

Application of the concepts of orthographic projection to the solution of three-dimensional problems arising in the various branches of engineering. Introductory computer aided drafting/design concepts or applications. Suggested preparation: Engineering 122 or 125.

\$4.00 material fee required for this course at registration.

W	3222801	8:00-1:05pm	S	Babikian A	SAC A-214	Full Semester
	AND	2 Hrs Arr		Staff	SAC A-225	

ENGINEERING 250, ELECTRIC CIRCUITS (CAN ENGR 12) 3 UNITS

(CAN ENGR 6 = ENGR 250+250L)

Ohm's and Kirchhoff's Laws; techniques for solving circuit problems; RC, RL, and RLC circuits, steady-state sinusoidal analysis, and polyphase circuits. Prerequisite: Mathematics 280, and Physics 227 (both may be taken concurrently).

	3225001	7:00-10:10pm	T	Takahashi C	SAC A-214	Full Semester
--	---------	--------------	---	-------------	-----------	---------------

ENGINEERING 250L, ELECTRIC CIRCUITS LABORATORY 1 UNIT

(CAN ENGR 6 = ENGR 250+250L)

Selected laboratory exercises in engineering circuit analysis. Prerequisite: Engineering 250 or concurrent enrollment.

\$2.00 material fee required for this course at registration.

	3225002	6:00-6:55pm	T	Takahashi C	SAC A-214	Full Semester
	AND	2 Hrs Arr		Staff	SAC A-225	

ENGLISH

ENGLISH N50 PLACEMENT INFORMATION: Prerequisite: Qualifying profile from English placement process. (Test times are listed in this schedule.) The English Department recommends that students who score below the 20th percentile on the reading placement test register concurrently in a Reading class.

ENGLISH N50, INTRODUCTION TO WRITTEN COMMUNICATION 3 UNITS

Introduction to written communication including autobiographical, journal and summary writing, and responding to essays. Basic grammar and punctuation. Designed for native speakers. Student may be referred to the Writing Center. Not applicable to associate degree. Prerequisite: Qualifying profile from English placement process.

	3305003	8:00-9:25	MW	Patterson K	SAC D-107	Full Semester
	3305002	8:00-9:25	TTh	Pham V	SAC B-8	Full Semester
	3305008	8:00-9:25	TTh	Beyersdorf M	SAC B-4	Full Semester
	3305001	9:00-12:10pm	F	Jolly J	SAC D-108	Full Semester
W	3305004	9:00-12:10pm	S	Benjumea P	SAC D-108	Full Semester
	3305005	6:00-9:10pm	F	Staff	SAC D-103	Full Semester

Can't find the class you need?

**It may be waiting for you at
Santiago Canyon College!**

**View SCC's class schedule at
www.sccollege.edu/schedule**

SCC's class schedule is included in this booklet.

Hurry! Class sizes are limited.

TKT#	TIME	DAYS	INSTRUCTOR	LOC./RM.	DATES
------	------	------	------------	----------	-------

ENGLISH N60 PLACEMENT INFORMATION: Prerequisite: Qualifying profile from English placement process (test times are listed in this schedule) OR grade of "C" or better in English N50. The English Department recommends that students who score below the 20th percentile on the reading placement test register concurrently in a Reading class.

ENGLISH N60, BASICS OF EFFECTIVE WRITING **3 UNITS**
 Review of sentence structure and basic paragraph writing. Designed for native speakers. Not applicable to associate degree. 16 additional hours in Writing Center required. Prerequisite: Grade of C or better in English N50 or qualifying profile from English placement process.

NOTE: ENGLISH N60 CLASSES REQUIRE LAB TIME OF ONE HOUR PER WEEK

3306011	7:30am-9:35	MW	Bassett D	SAC D-109	Full Semester
3306004	7:30am-9:35	TTh	Mitzner R	SAC L-202	Full Semester
3306001	8:00-10:05	TTh	Bennett G	SAC D-108	Full Semester
3306005	10:15-12:20pm	TTh	Brandon K	SAC D-214	Full Semester
3306030	1:30-3:35pm	MW	Brandon K	SAC B-6	Full Semester
3306017	6:00-10:15pm	M	Beyersdorf M	SAC D-213	Full Semester
3306018	6:00-10:15pm	T	Ward M	SAC D-108	Full Semester
3306019	6:00-10:15pm	W	Ward M	SAC D-207	Full Semester
3306020	6:00-10:15pm	Th	Sosta R	SAC D-212	Full Semester
3306023	6:00-10:15pm	F	Gomez F	SAC D-102	Full Semester

ENGLISH N60
 English 060 classes are available in Freshman Experience and Learning Communities II. Enrollment in all classes within a block is required. See additional information on page 26.

ENGLISH N60
 3306002 10:15 - 12:20 MW Bromberger K B-5 Full Semester

COUNSELING 116
 2011683 08:30 - 09:55 MW Scharf M R-303 Full Semester

ENGLISH N60
 3306006 8:00 - 10:05 MW Beyersdorf M D-204 Full Semester

COUNSELING 116
 2011670 10:15 - 11:40 MW Nguyen T H-207 Full Semester

ENGLISH 061 PLACEMENT INFORMATION: Prerequisite: Qualifying profile from English placement process (test times are listed in this schedule) OR grade of "C" or better in English N60. The English Department recommends that students who score below the 20th percentile on the reading placement test register concurrently in a Reading class.

ENGLISH 061, INTRODUCTION TO COMPOSITION **3 UNITS**
 Short expository writing. For native speakers only. 16 additional hours in Writing Center required. Prerequisite: Grade of C or better in English N60 or qualifying profile from English placement process.

NOTE: ENGLISH N61 CLASSES REQUIRE LAB TIME OF ONE HOUR PER WEEK

3306112	Hrs Arr		Carey J	SAC WEB	Full Semester
(Tckt No 3306112 requires on campus meetings: Tues Feb 12, Mar 11, Apr 15, Jun 3, 5:30-6:50pm, SAC D-103. See Online Courses page in class schedule or go to www.sac.edu/disted for more information.)					
3306104	7:45am-9:50	TTh	Gorrie K	SAC A-211	Full Semester
3306102	8:00-10:05	TTh	Daly N	SAC D-211	Full Semester
3306136	9:00-1:45pm	MTWTh	Higgins M	SAC D-110	1/8-1/31
3306109	9:45-11:50	MW	Ramshaw C	SAC D-206	Full Semester
3306103	10:15-12:20pm	TTh	Ramshaw C	SAC D-108	Full Semester
3306113	11:15-1:20pm	MW	Daly N	SAC R-113	Full Semester
3306118	11:30-1:35pm	TTh	Daly N	SAC D-201	Full Semester
3306116	12:00-2:05pm	MW	Higgins M	SAC D-108	Full Semester
3306110	12:00-2:05pm	TTh	Harris J	SAC B-4	Full Semester
3306114	12:00-2:05pm	TTh	Gorrie K	SAC D-109	Full Semester
3306101	12:30-2:35pm	TTh	Martinez D	SAC D-102	Full Semester
(Tckt No 3306101 emphasizes Chicano issues. Open to all students.)					
3306128	1:15-3:20pm	TTh	Brandon K	SAC B-8	Full Semester
3306125	1:15-5:20pm	TTh	Taylor J	SAC D-103	4/14-6/5
3306119	3:45-5:50pm	MW	Higgins M	SAC D-108	Full Semester
3306120	4:45-6:50pm	TTh	Nelson A	SAC D-109	Full Semester
3306122	6:00-10:15pm	M	Barraza G	SAC D-109	Full Semester
3306105	6:00-10:15pm	W	Simmerman S	SAC D-109	Full Semester
3306124	6:00-10:15pm	Th	Manzullo M	SAC D-305	Full Semester
3306126	6:00-10:15pm	F	Jolly S	SAC D-109	Full Semester
3306106	Hrs Arr		Bennett G	SAC WEB	Full Semester
(Tckt No 3306106 combines online and on campus instruction. Students must attend all of the following on-campus meetings: Tues, Feb 12, Mar 18, Apr 29, Jun 3, 5-6:50pm, SAC D-102. See Online Courses page in class schedule or go to www.sac.edu/disted for more information.)					

TKT#	TIME	DAYS	INSTRUCTOR	LOC./RM.	DATES
------	------	------	------------	----------	-------

ENGLISH 061
 English 061 classes are available in Freshman Experience and Learning Communities II. Enrollment in all classes within a block is required. See additional information on page 26.

ENGLISH 061
 3306134 9:30-11:35 TTh Jaffray S SAC B-4 Full Semester

COUNSELING 116
 2011673 12:00-1:25 TTh Liken-McCann L SAC B-31 Full Semester

ENGLISH 061
 3306115 11:30-1:35 MW Bassett D SAC D-109 Full Semester

COUNSELING 116
 2011681 10:00-11:25 MW Guzman S SAC J-101 Full Semester

ENGLISH 101 PLACEMENT INFORMATION: Prerequisite: Qualifying profile from English placement process (test times are listed in this schedule) OR grade of "C" or better in English 061 or ESL 112. The English Department recommends that students who score below the 20th percentile on the reading placement test register concurrently in a Reading class.

ENGLISH 101, FRESHMAN COMPOSITION **4 UNITS**

Expository and argumentative essays and the research paper. Prerequisite: Grade of C or better in English 061 or EMLS 112 or ACE 116 or qualifying profile from English placement process.

3310101	7:30am-9:25	MW	Mitzner R	SAC D-206	Full Semester
3310164	7:30am-9:25	TTh	Kane C	SAC D-109	Full Semester
3310147	8:00-10:05	MW	Daly N	SAC D-207	Full Semester
3310124	8:00-10:05	TTh	Hedgecock J	SAC D-206	Full Semester
3310123	8:00-12:15pm	F	La Tour J	SAC D-102	Full Semester
3310135	8:00-12:15pm	F	Bromberger K	SAC D-212	Full Semester
3310154	9:00-1:15pm	F	Kane C	SAC D-201	Full Semester
3310111	9:00-1:15pm	S	Campbell J	SAC D-109	Full Semester
3310160	9:00-1:45pm	MTWTh	Patterson K	SAC D-103	1/8-1/31
3310115	9:45-11:50	MW	Brandon K	SAC D-107	Full Semester
3310102	10:15-12:20pm	MW	Mitzner R	SAC D-207	Full Semester
3310122	11:30-1:35pm	TTh	Higgins M	SAC D-210	Full Semester
3310126	12:00-2:05pm	MW	Ramshaw C	SAC D-206	Full Semester
3310127	12:00-2:05pm	MW	Beyersdorf M	SAC D-107	Full Semester
3310155	1:00-5:45pm	MTWTh	Martinez D	SAC D-109	1/8-1/31
3310153	2:15-4:20pm	TTh	Staff	SAC D-109	Full Semester
3310133	4:00-6:05pm	TTh	Higgins K	SAC D-107	Full Semester
3310129	4:30-6:35pm	MW	Gomez F	SAC D-211	Full Semester
3310132	4:45-6:50pm	MW	Musgrove C	SAC D-212	Full Semester
3310131	4:45-6:50pm	TTh	Kaminsky R	SAC D-207	Full Semester
3310150	5:45-10:30pm	MTWTh	Jaffray S	SAC D-109	1/8-1/31
3310168	6:00-10:15pm	M	Jaffray S	SAC D-108	Full Semester
3310138	6:00-10:15pm	T	Kabaji N	SAC D-210	Full Semester
3310140	6:00-10:15pm	W	Nguyen P	SAC D-213	Full Semester
3310162	6:00-10:15pm	W	Staff	SAC B-6	Full Semester
3310139	6:00-10:15pm	Th	Anguiano J	SAC D-206	Full Semester
3310161	6:00-10:15pm	Th	Whynaught J	SAC D-210	Full Semester
3310141	6:00-10:15pm	F	Johnson S	SAC D-305	Full Semester
3310121	Hrs Arr		Bennett G	SAC WEB	Full Semester

(Tckt No 3310121 combines online and on campus instruction. Mandatory on campus meetings: Thur, Feb 14, Mar 20, May 1, Jun 5, 5-6:50pm, SAC D-204. See Online Courses page in class schedule or go to www.sac.edu/disted for more information.)

3310165 Hrs Arr Pearce D SAC WEB Full Semester
 (Tckt No 3310165 combines online and on campus instruction. Mandatory on-campus meetings: Thurs, Feb 14, Mar 13, Apr 17, May 15, Jun 5, 4-5:50pm, SAC D-303. See Online Courses page in class schedule or go to www.sac.edu/disted for more information.)

3310166 Hrs Arr Kabaji N SAC WEB Full Semester
 (Tckt No 3310166 combines online and on campus instruction. Mandatory on-campus meetings: Tues, Feb 12, Mar 11, Apr 22, May 20, Jun 3, 4-5:50pm, SAC D-303. See Online Courses page in class schedule or go to www.sac.edu/disted for more information.)

3310169 Hrs Arr Nguyen P SAC WEB Full Semester
 (Tckt No 3310169 combines online and on campus instruction. Mandatory on-campus meetings: Tues, Feb 12, Mar 25, May 13 Jun 3, 4-5:50pm, SAC D-210. See Online Courses page in class schedule or go to www.sac.edu/disted for more information.)

ENGLISH 101
 English 101 classes are available in Freshman Experience and Learning Communities II. Enrollment in all classes within a block is required. See additional information on page 26.

ENGLISH 101
 3310151 11:30-1:35pm TTh Mitzner R SAC B-7 Full Semester

COUNSELING 116
 2011676 9:30-10:55 TTh Kelley M SAC B-13 Full Semester

ENGLISH 101
 3310110 10:00-12:05pm TTh Huck T SAC D-207 Full Semester

PSYCHOLOGY 100
 7710002 8:00-9:25 TTh Ortiz F SAC D-102 Full Semester

COUNSELING 116
 2011679 12:30-1:55pm TTh Everett K SAC B-29 Full Semester

Academic Planning Questions?
www.sac.edu/online_counseling

TKT#	TIME	DAYS	INSTRUCTOR	LOC./RM.	DATES
ENGLISH 101					
3310116	10:15-12:20pm	MW	Martinez D	SAC D-102	Full Semester
COUNSELING 116					
2011674	8:00-9:25	MW	Lockhart A	SAC A-215	Full Semester
PUENTE					
ENGLISH 101					
3310105	10:15-12:20pm	TTh	Martinez D	SAC D-213	Full Semester
COUNSELING 111					
2011101	12:30-1:25pm	T	Sanabria R	SAC C-202	Full Semester

ENGLISH 101H, HONORS FRESHMAN COMPOSITION **4 UNITS**
 Enriched exposure to expository and argumentative essays and the research paper emphasizing in-depth treatment of topics. Prerequisite: A high school or college GPA of 3.0 or above and a grade of C or better in English 061 or EMLS 112 or ACE 116 or qualifying profile from English placement process.

3310176	7:30am-9:35	TTh	Bassett D	SAC B-7	Full Semester
---------	-------------	-----	-----------	---------	---------------

ENGLISH 102, LITERATURE AND COMPOSITION **4 UNITS**
 Analytical writing. An introduction to the study of literature with assigned readings from the following: short story, novel, drama, and poetry. Prerequisite: A grade of C or better in English 101 or English 101H.

3310208	Hrs Arr		Ramshaw C	SAC WEB	Full Semester
(Tckt No 3310208 combines online and on campus instruction. Mandatory on-campus meetings: Mon, Feb 11, Mar 17, Apr 21, May 19, 3:45-5:45pm, SAC D-102. See Online Line Courses page in class schedule or go to www.sac.edu/disted for more information.)					
3310203	8:00-10:05	MW	Menke K	SAC B-7	Full Semester
3310204	8:00-10:05	TTh	Read-Davidson M	SAC D-214	Full Semester
3310206	9:45-11:50	TTh	Taylor J	SAC D-109	Full Semester
3310205	1:00-3:05pm	MW	Martinez D	SAC D-102	Full Semester

ENGLISH 102
 English 102 classes are available in Freshman Experience and Learning Communities II. Enrollment in all classes within a block is required. See additional information on page 26.

ENGLISH 102					
3310207	11:30-1:35pm	TTh	Bassett D	SAC B-6	Full Semester

U-LINK
ENGLISH 102
 3310202 10:15-12:20pm MW Patterson K SAC B-7 Full Semester
COUNSELING 128
 2012802 12:45-3:55pm W Pratt L SAC A-130 Full Semester

ENGLISH 103, CRITICAL THINKING AND WRITING **4 UNITS**
 Argumentative and analytical writing with an emphasis on critical thinking and writing. Prerequisite: English 101 or 101H with a grade of C or better.

3310307	8:00-10:05	MW	Bennett G	SAC D-102	Full Semester
3310311	9:00-1:45pm	MTWTh	Ramshaw C	SAC D-211	1/8-1/31
3310313	12:45-2:50pm	MW	Mitznier R	SAC D-207	Full Semester
3310314	6:00-10:15pm	T	Dickinson A	SAC B-5	Full Semester
3310305	6:00-10:15pm	W	Greenberg H	SAC D-108	Full Semester
3310312	6:00-10:15pm	W	Menke K	SAC B-7	Full Semester
3310310	Hrs Arr		Beyersdorf M	SAC WEB	Full Semester

(Tckt No 3310310 combines online instruction. Mandatory on-campus meetings: Wed, Feb 13, Mar 19, Apr 30, Jun 4, 5-6:50pm, SAC D-102. See Online Courses page in class schedule or go to www.sac.edu/disted for more information.)

ENGLISH 103
 English 103 classes are available in Freshman Experience and Learning Communities II. Enrollment in all classes within a block is required. See additional information on page 26.

ENGLISH 103					
3310308	8:00-10:05	TTh	Grunkemeyer C	SAC D-213	Full Semester
COUNSELING 116					
2011680	11:00-12:25	TTh	Pichardo D	SAC A-203	Full Semester

ENGLISH 103H, HONORS CRITICAL THINKING AND WRITING **4 UNITS**
 Enriched exposure to argumentative writing with an emphasis on critical thinking and writing. Prerequisite: A high school or college GPA of 3.0 or above and a grade of C or better in English 101 or 101H.

3310377	1:15-3:20pm	MW	Munoz J	SAC D-211	Full Semester
---------	-------------	----	---------	-----------	---------------

ENGLISH 103H
 English 103H classes are available in Freshman Experience and Learning Communities II. Enrollment in all classes within a block is required. See additional information on page 26.

U-LINK
ENGLISH 103H
 3310375 8:00-10:05 TTh Patterson K SAC B-5 Full Semester
INTERDISCIPLINARY STUDIES 117H
 5211701 1:00 – 4:10 M Wood S SAC D-401 Full Semester
COUNSELING 128
 2012803 12:45-3:55pm W Zook R SAC A-207 Full Semester



On the Road to Success!!
 Build your skills in Basic Math, Reading, English and ESL – on your own time!!

The Success Center
 Library Building, Room L-206

We want to help you build your basic skills! Set your own arranged hours developing the skills you need for your college classes. Sign up for IDS N04, Essential Basic Skills, 0 units, open entry/open exit.

This is YOUR center, dedicated to helping you! Come by L-206 and check it out!

ENGLISH 206, INTRODUCTION TO LANGUAGE STRUCTURE AND USE **3 UNITS**
 Introduction to the nature and structure of human language, first and second language acquisition, development of literacy, and language use. Comparisons of languages in the local area will be explored. Prerequisite: English 101 or 101H.

3320601	8:00-9:25	MW	Jaros B	SAC B-5	Full Semester
---------	-----------	----	---------	---------	---------------

ENGLISH 211, CREATIVE WRITING I/FICTION **3 UNITS**
 Writing techniques and critiquing strategies focusing on the short story. May be repeated. Prerequisite: English 101 or 101H.

3321101	7:00-10:10pm	M	Higgins M	SAC D-107	Full Semester
---------	--------------	---	-----------	-----------	---------------

ENGLISH 212, CREATIVE WRITING II/FICTION **3 UNITS**
 Writing techniques and critiquing strategies focusing on the longer short story or novel. May be repeated. Prerequisite: English 211.

3321201	7:00-10:10pm	M	Higgins M	SAC D-107	Full Semester
---------	--------------	---	-----------	-----------	---------------

ENGLISH 233A, SHAKESPEARE'S COMEDIES AND ROMANCES **3 UNITS**
 Shakespearean comedies and romances, emphasizing depiction of human nature and timeless conflicts. (Same as Theatre Arts 233A.) Prerequisite: English 101 or 101H.

3323301	7:00-10:10pm	W	Patterson K	SAC B-8	Full Semester
---------	--------------	---	-------------	---------	---------------

ENGLISH 242, SURVEY OF AMERICAN LITERATURE, 1860-PRESENT (CAN ENGL 16) (CAN ENGL SEQ C = ENGL 241+242) **3 UNITS**
 Survey of America's greatest works of literature and their contributions to American culture from 1860 to present. Prerequisite: English 101 or 101H.

3324201	11:30-12:55pm	MW	Bennett G	SAC B-4	Full Semester
---------	---------------	----	-----------	---------	---------------

ENGLISH 270, CHILDREN'S LITERATURE **3 UNITS**
 A study of literature for children emphasizing the history, trends, issues, and evaluation of all vmajor genres: picture books, poetry, drama, traditional literature, non-fiction, and fiction, including full-length works. Prerequisite: English 101 or 101H with a grade of C or better.

3327004	8:00-9:25	MW	Simmerman S	SAC B-6	Full Semester
3327003	7:00-10:10pm	T	Carey J	SAC D-305	Full Semester

ENGLISH 272, SURVEY OF WORLD LITERATURE **3 UNITS**
 Survey of world literacy masterworks since the Renaissance. Prerequisite: English 101 or 101H.

3327203	3:45-6:55pm	M	Prothero J	SAC D-204	Full Semester
---------	-------------	---	------------	-----------	---------------

ENGLISH AS A SECOND LANGUAGE

SEE ALSO
ENGLISH FOR MULTILINGUAL STUDENTS

ENGLISH AS A SECOND LANGUAGE N40A, INTRODUCTION TO ACADEMIC ESL I **1 UNIT**
 Practice in listening, speaking, reading, grammar, and study skills. Controlled writing at the sentence level. Lab may be required. Not applicable to associate degree. Grade: CR/NCR only. Prerequisite: Qualifying profile from ESL placement process.

3354005	8:00-11:10	TTh	Keith K	SAC B-6	Full Semester
3354002	7:00-10:10pm	TTh	Staff	SAC D-211	Full Semester
3354006	7:00-10:10pm	TTh	Whitsett C	SAC D-204	Full Semester

ENGLISH AS A SECOND LANGUAGE N40B, INTRODUCTION TO ACADEMIC ESL II **1 UNIT**
 Beginning academic ESL course. Further practice in listening, speaking, reading, grammar, and study skills. Controlled writing at the sentence level. Lab may be required. Not applicable to associate degree. Grade: CR/NCR only. Prerequisite: Credit in ESL N40A or qualifying profile from ESL placement process.

3354001	8:00-11:10	TTh	Lewis M	SAC D-103	Full Semester
3354004	7:00-10:10pm	TTh	Beaver D	SAC B-8	Full Semester

NOTE: SOME ENGLISH AS A SECOND LANGUAGE CLASSES REQUIRE LAB TIME

SANTA ANA COLLEGE ESL/ENGLISH FOR MULTI-LINGUAL STUDENTS (EMLS)

The ESL/English For Multi-Lingual Students Program is offered by the English Department for students whose native language is not English. Courses are offered AT the beginning, intermediate, and advanced levels. Initial placement into courses is the result of language testing using the ESL/EMLS Placement Test and advisement.

ESL test scores from other institutions are not accepted. ESL students who have completed ESL credit courses at other colleges and are still in need of additional English instruction must take the placement test at Santa Ana College or Santiago Canyon College, to determine which courses best meet their needs.

Courses in the program include ESL N40A, ESL N40B, ESL N49, EMLS 055, EMLS 107, EMLS 109, EMLS 110, and EMLS 112. Supplemental enrollments in speech and reading courses are shown in the diagram below. Non-native speakers of English wishing to enter the transfer English program, which begins with English 101, must meet the following requirements:

- Completion of EMLS 112 with grade of "C" or higher
- OR Qualifying profile from ESL/EMLS placement process & advisement
- AND Advisory Prerequisite: Qualification for Reading 100 on Reading Placement Test.

The following diagram summarizes the program and requirements:

ENGLISH AS A SECOND LANGUAGE

ESL	Test Score / Placement	Recommended Speech Communication Classes	Recommended Reading Classes
ESL N40A Introduction to Academic ESL I 1 unit	= Qualifying profile from ESL/EMLS placement process	None	None
ESL N40B Introduction to Academic ESL II 1 unit	= Qualifying profile from ESL/EMLS placement process OR completion of ESL N40A with a grade of "Credit"	None	
ESL N49, Reading, Writing & Grammar I 3 units	= Qualifying profile from ESL/EMLS placement process OR completion of ESL N40B with a grade of "Credit"	Speech Communication N50 .5-1 unit	

ENGLISH FOR MULTI-LINGUAL STUDENTS

EMLS 055, Writing, Grammar and Reading I 4 units	= Qualifying profile from ESL/EMLS placement process OR completion of ESL N49 with a grade of "C" or higher	Speech Communication N52A 3 units	Reading N80AB, or Reading N90AB <i>(Individualized Reading)</i>
EMLS 107, Writing, Grammar & Reading II 4 units	= Qualifying profile from ESL/EMLS placement process OR completion of EMLS 055 with a grade of "C" or higher	Speech Communication N52AB 3 units	May be taken throughout the ESL/EMLS program for up to 6.0 units of credit. 1-3 units may be earned each semester. See specific class listings in this schedule.
EMLS 109, Writing, Grammar and Reading III 4 units	= Qualifying profile from ESL/EMLS placement process OR completion of EMLS 107 with a grade of "C" or higher	Speech Communication 096, 097 3 units Speech Communication N53 3 units	
EMLS 110, Introduction to the Essay 3 units	= Qualifying profile from ESL/EMLS placement process OR completion of EMLS 109 with a grade of "C" or higher	Speech Communication 096, 097 3 units Speech Communication N53 3 units	

TRANSITION TO COLLEGE ENGLISH TRANSFER PROGRAM

EMLS 112, Advanced ESL Composition 3 units	= Qualifying profile from ESL/EMLS placement process OR completion of EMLS 110 with a grade of "C" or higher	Speech Communication N50 3 units	Reading N90AB or Reading 100AB. 1-3 units may be earned each semester up to a maximum of 6.0 units.
--	--	-------------------------------------	---

COLLEGE ENGLISH TRANSFER PROGRAM

English 101 OR 101H Freshman Composition 4 units	= Qualifying profile from English placement process OR completion of EMLS 112 with a grade of "C" or higher AND Advisory Reading Level: Qualification for Reading 100 on Reading Placement Test.	Speech Communication 101 Introduction to Interpersonal Communication 3 units Speech Communication 102 Public Speaking 3 units	Additional reading as needed or desired by student.
---	---	--	---

TKT#	TIME	DAYS	INSTRUCTOR	LOC./RM.	DATES
------	------	------	------------	----------	-------

ENGLISH AS A SECOND LANGUAGE N49, READING, WRITING & GRAMMAR I 3 UNITS

Sentence practice and controlled composition, emphasizing use of simple and progressive verb tenses. Grammar practice and review. Critical reading. Lab hours are required. Not applicable to associate degree. Prerequisite: Credit in ESL N40B or qualifying profile from ESL placement test.

3354901	8:00-11:10	MW	Lewis M	SAC D-214	Full Semester
3354903	11:00-2:10pm	MW	Keith K	SAC L-202	Full Semester
3354905	7:00-10:10pm	TTh	Zamoyska C	SAC D-303	Full Semester
3354906	7:00-10:10pm	TTh	Seyster B	SAC D-207	Full Semester

ENGLISH AS A SECOND LANGUAGE (SEE AMERICAN COLLEGE ENGLISH)

ENGLISH FOR MULTILINGUAL STUDENTS

SEE ALSO
ENGLISH AS A SECOND LANGUAGE

ENGLISH FOR MULTILINGUAL STUDENTS 055, WRITING, GRAMMAR AND READING I 4 UNITS

Sentence-level writing for multilingual students who speak English but often make grammar mistakes when they write. Practice with narrative paragraphs and journal writing, emphasizing correct verb forms and tenses and modals. Grammar practice and review. Critical reading. Lab hours are required. Prerequisite: Grade of C or better in ESL N49 or qualifying profile from ESL placement process.

3375501	8:00-11:10	MW	Erohina T	SAC D-211	Full Semester
3375503	11:30-2:40pm	MW	Hassel E	SAC D-201	Full Semester
3375504	1:15-4:25pm	MW	Sabha F	SAC D-209	Full Semester
3375506	2:00-5:10pm	MTWTh	Staff	SAC B-31	4/14-6/5
3375507	7:00-10:10pm	MW	Beasley J	SAC B-5	Full Semester
3375502	7:00-10:10pm	TTh	Baker E	SAC D-107	Full Semester
3375510	7:00-10:10pm	TTh	Civen I	SAC D-201	Full Semester

NOTE: SOME ENGLISH AS A SECOND LANGUAGE (ESL) AND ENGLISH FOR MULTILINGUAL STUDENTS (EMLS) CLASSES REQUIRE LAB TIME

ENGLISH FOR MULTILINGUAL STUDENTS 107, WRITING, GRAMMAR AND READING II 4 UNITS

Sentence and paragraph level writing for multilingual students who speak English but often make grammar mistakes when they write. Practice with narrative and descriptive paragraphs, emphasizing vocabulary, unity, and sentence subordination and variety. Grammar practice and review. Critical reading. Lab hours are required. Prerequisite: Grade of C or better in EMLS 055 or qualifying profile from ESL placement process.

3380702	8:00-11:10	MW	Mallory L	SAC D-212	Full Semester
3380704	8:00-11:10	TTh	Ehresmann B	SAC D-107	Full Semester
3380705	11:30-2:40pm	MW	Ehresmann B	SAC D-103	Full Semester
3380707	12:30-3:40pm	MW	Lewis M	SAC B-7	Full Semester
3380710	7:00-10:10pm	MW	Cavina K	SAC D-201	Full Semester
3380711	7:00-10:10pm	MW	Baumheckel K	SAC D-211	Full Semester
3380712	7:00-10:10pm	TTh	Mallory L	SAC B-29	Full Semester

ENGLISH FOR MULTILINGUAL STUDENTS 109, WRITING, GRAMMAR AND READING III 4 UNITS

Paragraph-level writing for multilingual students who speak English but often make grammar mistakes when they write. Practice with narrative, descriptive and expository paragraphs, incorporating all elements of good development. Grammar practice and review. Critical reading. Lab hours are required. Prerequisite: Grade of C or better in EMLS 107 or qualifying profile from ESL placement process.

3380902	8:00-11:10	MW	Naum M	SAC B-31	Full Semester
3380901	8:00-11:10	TTh	Hicks R	SAC D-212	Full Semester
3380905	11:30-2:40pm	MW	Dwyer D	SAC D-303	Full Semester
3380904	12:30-3:40pm	TTh	Ferrell K	SAC D-108	Full Semester
3380907	1:15-4:25pm	TTh	Dwyer D	SAC D-212	Full Semester
3380909	3:30-6:40pm	MW	Ferrell K	SAC D-208	Full Semester
3380911	7:00-10:10pm	MW	Woodruff S	SAC B-9	Full Semester
3380912	7:00-10:10pm	MW	Nau J	SAC B-19	Full Semester
3380903	7:00-10:10pm	TTh	Myers D	SAC D-205	Full Semester

ENGLISH FOR MULTILINGUAL STUDENTS 110, INTRODUCTION TO THE ESSAY 3 UNITS

Introductory writing course for multilingual students who speak English fluently but often make grammar mistakes when they write. Paragraph review and introduction to essay writing using modes such as illustration by examples and reasons, and narration. Grammar review. Critical reading. Revising and editing. Lab hours are required. Prerequisite: Grade of C or better in EMLS 109 or qualifying profile from ESL placement process.

3381002	8:00-10:05	MW	Keith K	SAC B-8	Full Semester
3381004	9:45-11:50	TTh	Dwyer D	SAC D-303	Full Semester
3381007	1:45-3:50pm	TTh	Sleep K	SAC D-201	Full Semester
3381009	4:45-6:50pm	MW	Seidel M	SAC D-214	Full Semester
3381011	6:00-10:10pm	T	Hassel E	SAC D-206	Full Semester
3381010	6:00-10:15pm	M	Josifek J	SAC D-207	Full Semester

TKT#	TIME	DAYS	INSTRUCTOR	LOC./RM.	DATES
------	------	------	------------	----------	-------

Online Counseling Now Available!
www.sac.edu/online_counseling

ENGLISH FOR MULTILINGUAL STUDENTS 112, ADVANCED COMPOSITION 3 UNITS

Advanced level writing course for multilingual students who speak English fluently but make multiple grammar errors when writing. Essay writing in modes such as cause/effect, classification, comparison or contrast. Revising and editing. Research methods. Critical reading. Lab may be recommended. Prerequisite: Grade of C or better in EMLS 110 or qualifying profile from ESL placement process.

3381201	8:00-10:05	MW	Cho D	SAC G-106	Full Semester
3381204	9:45-11:50	MW	Cervantes M	SAC D-434	Full Semester
3381208	11:30-1:35pm	MW	Ferrell K	SAC D-213	Full Semester
3381206	12:30-2:35pm	TTh	Ehresmann B	SAC D-107	Full Semester
3381209	6:00-10:15pm	M	Cervantes M	SAC D-102	Full Semester
3381210	6:00-10:15pm	Th	Sleep K	SAC D-213	Full Semester

NOTE: Some English As A Second Language (ESL) and English For Multilingual Students (EMLS) classes require lab time.

ENVIRONMENTAL STUDIES

ENVIRONMENTAL STUDIES 200, ENVIRONMENT OF MAN 3 UNITS

Study of current problems such as energy, food, resources, population, and land use, including economic and political factors. Class discussion, films, demonstrations, field trips. A Natural Science elective. (Same as Biology 200 and Science 200.)

3420001	7:00-10:10pm	T	Chlup I	SAC R-228	Full Semester
---------	--------------	---	---------	-----------	---------------

ETHNIC STUDIES

ETHNIC STUDIES 101, INTRODUCTION TO ETHNIC STUDIES 3 UNITS

Historical and cultural survey of ethnic groups and relations in the U.S. among Anglos, Native Americans, Asian Americans, African Americans, Mexican Americans/Latinos from the pre-Columbian period to present.

9760101	12:00-1:25pm	TTh	Staff	SAC D-303	Full Semester
9760103	7:00-10:10pm	W	Vu H	SAC B-31	Full Semester

ETHNIC STUDIES 102, THE BORDERLANDS: CULTURAL CONTEXT & INTERCULTURAL RELATIONS 3 UNITS

Analysis of U.S.-Mexico border region: geographic, historic, and artistic significance. Discussion of (borders) as they concern intercultural relations. Attention given to African American, Asian American, Chicano/Latino, & Native American ethnic groups within mainstream U.S. society.

9760201	7:00-10:10pm	Th	Veyna A	SAC D-108	Full Semester
---------	--------------	----	---------	-----------	---------------

Ethnic Studies Degree Courses

COURSE	DESCRIPTION
ANTH 100	Introduction to Cultural Anthropology
ART 103	African Art
ART 104	Mexican & Chicano/Chicana Art History
ART 106	Asian Art History
BLACK ST 101	Introduction to Black Studies
CHIC ST 101	Introduction to Chicano Studies
DNCE 105	World Dance and Cultures
DNCE 110	Beginning Mexican Folk Dance
DNCE 113A/B	Flamenco Dance
ETH ST 101	Introduction to Ethnic Studies
HIST 101	World Civilizations to the 16th Century
HIST 102	World Civilizations Since the 16th Century
HIST 124	Mexican American History in the U.S.
HIST 153	History of Mexico
HUM DEV 221	Cross Cultural Perspectives in Early Childhood Education
MUS 102	World Music
MUS 103	Jazz in America
SOC 100	Introduction to Sociology
SPAN 101	Elementary Spanish I
SPAN 102	Elementary Spanish II
VIET 101	Elementary Vietnamese I
VIET 102	Elementary Vietnamese II

TKT#	TIME	DAYS	INSTRUCTOR	LOC./RM.	DATES
------	------	------	------------	----------	-------

EXERCISE CAUTION

Many of the following physical fitness courses may involve strenuous exercise and may cause bodily injury. All participants should be in good physical condition. A medical examination is suggested prior to any strenuous physical activity. Participants should notify the instructor if special arrangements are necessary.

EXERCISE SCIENCE ACTIVITIES

E.S. ACTIVITIES N70, BASIC ACTIVITIES**1 UNIT**

Instruction and practice in the fundamentals and strategies of a variety of physical activities. May be repeated.

3507005	10:00-10:55	TTh	Breig D	SOCC FLD	Full Semester
3507001	11:00-11:55	MW	Nutter K	SOCC FLD	Full Semester
3507002	12:00-12:55pm	MW	Nutter K	SOCC FLD	Full Semester
3507003	1:00-1:55pm	TTh	Breig D	SOCC FLD	Full Semester

E.S. ACTIVITIES 107, BADMINTON**1 UNIT**

Instruction and experience in the fundamental skills and strategies of badminton. May be repeated.

3510701	9:00-10:25	TTh	Breig D	SAC G-105	Full Semester
3510702	7:00-10:10pm	T	Ogas D	SAC G-105	Full Semester

E.S. ACTIVITIES 130, GOLF**1 UNIT**

The fundamentals of golf with emphasis on the short game, chipping, pitching and putting. May be repeated.

3513006	4:00-5:25pm	TTh	Gorrie R	RIVE GOLF	Full Semester
---------	-------------	-----	----------	-----------	---------------

(The first class session for ESAC 130, Golf will meet at Santa Ana College outside room W-102)

E.S. ACTIVITIES 132, GOLF-PLAYING LESSON**1 UNIT**

Applies advanced techniques of golf play on a regulation course. May be repeated.

3513203	4:00-7:10pm	M	Ogas D	RIVE GOLF	Full Semester
---------	-------------	---	--------	-----------	---------------

(The first class session for ESAC 132, Golf will meet at Santa Ana College outside room F-116)

E.S. ACTIVITIES 140, KARATE**1 UNIT**

Instruction in the Japanese art of Karate with an emphasis on mental and physical conditioning to develop coordination, balance, speed and power for self defense applications. May be repeated.

3514001	5:30-6:55pm	MW	Hines D	SAC W-111	Full Semester
---------	-------------	----	---------	-----------	---------------

E.S. ACTIVITIES 150, HATHA YOGA**1 UNIT**

The history, philosophy and practice of physical Hatha Yoga. Emphasis on improving muscle tone, flexibility, breath control, relaxation and the unity of mind, body and spirit. May be repeated.

3515003	11:00-12:25pm	MW	Doty A	SAC W-106	Full Semester
---------	---------------	----	--------	-----------	---------------

E.S. ACTIVITIES 150, HATHA YOGA**0.5 UNITS**

The history, philosophy and practice of physical Hatha Yoga. Emphasis on improving muscle tone, flexibility, breath control, relaxation and the unity of mind, body and spirit. May be repeated.

3515002	8:00-10:05	F	Ward M	SAC W-111	Full Semester
3515001	4:00-6:05pm	T	Ward M	SAC W-111	Full Semester

E.S. ACTIVITIES 155, SELF DEFENSE**1 UNIT**

Instruction in personal safety and self-protection including the effective use of hands, knees, feet, elbows, and the mind. May be repeated.

3515502	7:30-8:55pm	TTh	Juliano R	SAC W-106	Full Semester
---------	-------------	-----	-----------	-----------	---------------

E.S. ACTIVITIES 160, TENNIS**1 UNIT**

Instruction and practice in the fundamental skills basic to successful performance in tennis. Singles and doubles tournament play. Includes all strokes; ground, volley, lob, serve, return of serve, overhead. May be repeated.

W 3516009	9:00-12:10pm	F	Brown M	TENN CRTS	Full Semester
3516001	11:00-1:05pm	Su	Manuel R	TENN CRTS	Full Semester

E.S. ACTIVITIES 160, TENNIS**0.5 UNITS**

Instruction and practice in the fundamental skills basic to successful performance in tennis. Includes all strokes; ground, volley, lob, serve, return of serve, overhead. May be repeated.

W 3516005	9:00-11:05	S	Staff	TENN CRTS	Full Semester
-----------	------------	---	-------	-----------	---------------

E.S. ACTIVITIES 185, AIKIDO**0.5 UNITS**

A survey of traditional Aikido mental, physical and ethical training. Through intense physical training, the philosophy and ethics of Aikido are transferred to daily life in the form of stress reduction, self-confidence and self-discovery. May be repeated.

3518501	10:10-12:15pm	F	Ward M	SAC W-111	Full Semester
---------	---------------	---	--------	-----------	---------------

E.S. ACTIVITIES 200, INTRAMURAL SPORTS-BASKETBALL**1 UNIT**

This class is designed to provide students with an opportunity to participate and compete against classmates in the sport of basketball. May be repeated. Grade: CR/NCR only.

3520001	3:00-6:20pm	MW	Luppani M	SAC G-105	4/14-6/4
3520002	3:45-7:05pm	TTh	Breig D	SAC G-105	4/15-6/5

TKT#	TIME	DAYS	INSTRUCTOR	LOC./RM.	DATES
------	------	------	------------	----------	-------

E.S. ACTIVITIES 220, BASKETBALL**1 UNIT**

Instruction and practice in the fundamentals, rules, strategies, philosophies and theories of basketball. May be repeated.

3522001	11:00-12:25pm	TTh	Brown M	SAC G-105	Full Semester
3522003	7:00-10:10pm	M	Brown M	SAC G-105	Full Semester
3522002	7:00-10:20pm	WF	Brown M	SAC G-105	4/16-6/6

E.S. ACTIVITIES 260, SOCCER**1 UNIT**

Individual skills leading to group and team tactics. Emphasis on defense, midfield and attack. May be repeated.

3526003	11:15-12:40pm	TTh	Coffman J	SOCC FLD	Full Semester
---------	---------------	-----	-----------	----------	---------------

E.S. ACTIVITIES 260, SOCCER**0.5 UNITS**

Individual skills leading to group and team tactics. Emphasis on defense, midfield and attack. May be repeated.

W 3526001	10:00-12:05pm	S	De Simone K	SOCC FLD	Full Semester
-----------	---------------	---	-------------	----------	---------------

E.S. ACTIVITIES 265, INDOOR-SOCCER**1 UNIT**

Individual skills leading to group and team tactics played in a gym. Emphasis on defense, midfield and attack. May be repeated.

3526501	7:00-10:10pm	W	Coffman J	SAC W-107	Full Semester
---------	--------------	---	-----------	-----------	---------------

E.S. ACTIVITIES 290, VOLLEYBALL**1 UNIT**

Instruction and practice in fundamental skills techniques, and strategies of volleyball. Basic rules, team offenses and defenses, and team concepts. May be repeated.

3529004	7:00-10:10pm	Th	Gorrie R	SAC G-105	Full Semester
---------	--------------	----	----------	-----------	---------------

E.S. ACTIVITIES 292, ADVANCED VOLLEYBALL-WOMEN**1 UNIT**

An advanced volleyball course designed for female athletes who have intercollegiate, USA club, or varsity high school volleyball experience. Emphasis will be placed on advanced technical skill development, offensive and defensive systems analysis, and sport specific physical fitness assessment and conditioning activities. May be repeated.

3529201	7:00-10:10pm	T	Abbey T	SAC W-107	Full Semester
---------	--------------	---	---------	-----------	---------------

EXERCISE SCIENCE ADAPTED ACTIVITIES

E.S. ADAPTED ACTIVITIES N15, ADAPTED FITNESS-SENIORS**0.5 UNITS**

A total fitness conditioning program based on sound physiological principles geared specifically to senior citizens. Physician's approval recommended for participation. Not applicable to associate degree. May be repeated.

3521501	10:00-10:55	TTh	Reily C	SAC G-105	Full Semester
---------	-------------	-----	---------	-----------	---------------

E.S. ADAPTED ACTIVITIES 202, ADAPTED CIRCUIT WEIGHT TRAINING**0.5 UNITS**

The class is an individually structured exercise program for adapted students. May be repeated. Grade: CR/NCR only.

3540202	1:00-1:55pm	MW	Brown M	SAC E-102	Full Semester
---------	-------------	----	---------	-----------	---------------

E.S. ADAPTED ACTIVITIES 205, ADAPTED BADMINTON**0.5 UNITS**

Fundamentals of badminton play, teamwork, rules and court strategy, are introduced for the temporarily and permanently disabled student. May be repeated. Grade: CR/NCR only.

3540501	10:00-10:55	TTh	Brown M	SAC G-105	Full Semester
---------	-------------	-----	---------	-----------	---------------

E.S. ADAPTED ACTIVITIES 208, ADAPTED AEROBICS**0.5 UNITS**

Aerobic and stretching exercises which are set to music and performed. Improves heart, firms body and increases endurance. May be repeated. Grade: CR/NCR only.

3540801	10:00-10:55	TTh	Shine C	SAC G-105	Full Semester
3540802	10:00-10:55	MW	Shine C	SAC W-107	Full Semester

EXERCISE SCIENCE AEROBIC FITNESS

E.S. AEROBIC FITNESS 140, WALKING/JOGGING FOR FITNESS**1 UNIT**

This course will emphasize jogging/walking for optimum health and fitness. This class is designed to improve cardiovascular health and total body toning through aerobic and anaerobic conditioning. May be repeated.

3554001	7:00am-8:25	MW	Nutter K	TRCK FLD	Full Semester
---------	-------------	----	----------	----------	---------------

E.S. AEROBIC FITNESS 146, STABILITY BALL TRAINING FOR FITNESS**1 UNIT**

A core training and strengthening workout. A full body workout using stability balls, designed to obtain total toning and strength. May be repeated.

3554601	1:30-2:55pm	MW	Tyler D	SAC W-106	Full Semester
---------	-------------	----	---------	-----------	---------------

E.S. AEROBIC FITNESS 150, STRETCH, FLEX AND TONE**1 UNIT**

A combination of stretching and toning exercises to increase strength, flexibility, and overall body fitness. May be repeated.

3555006	10:00-11:25	TTh	Nutter K	SAC W-107	Full Semester
---------	-------------	-----	----------	-----------	---------------

E.S. AEROBIC FITNESS 150, STRETCH, FLEX & TONE**0.5 UNITS**

A combination of stretching and toning exercises to increase strength, flexibility, and overall body fitness. May be repeated.



3555001	12:30-1:25pm	MW	MacDonald J	SAC W-107	Full Semester
---------	--------------	----	-------------	-----------	---------------

HAVE FUN GETTING IN SHAPE!

CARDIO PUMP

ESAF 198

Strength training at a cardio pace.
You choose the weight and work
at your own pace.

E.S. AEROBIC FITNESS 155, AEROBICS **0.5 UNITS**
Aerobic exercises, strength routines and stretching activities set to music designed to improve cardiovascular endurance and enhance muscular strength and flexibility. May be repeated.

W	3555501	8:00-10:05	S	Staff	SAC G-105	Full Semester
	3555504	6:00-6:55pm	TTh	Benson M	SAC W-107	Full Semester

E.S. AEROBIC FITNESS 156, CARDIO BOXING **0.5 UNITS**
A series of boxing, kickboxing, stretching exercises arranged to music, gradually increasing in tempo with a greater emphasis on a non-stop 25-30 minute program with 10-15 minutes of abdominal work and stretching. Aerobic activity is designed to improve muscle tone and cardiovascular endurance. May be repeated.

	3555602	7:00am-7:55	MW	Tyler D	SAC W-107	Full Semester
	3555606	10:00-10:55	MW	Luppani M	SAC G-105	Full Semester
	3555604	11:00-1:05pm	F	Tyler D	SAC W-107	Full Semester
	3555601	5:00-5:55pm	MW	Howell A	SAC W-107	Full Semester
	3555603	7:00-9:05pm	M	Abdrabou D	SAC W-107	Full Semester

E.S. AEROBIC FITNESS 158, STEP AEROBICS **0.5 UNITS**
An exercise program combining stretching, aerobic and resistive exercises to strengthen and tone the body as a way of improving and enhancing physical fitness. May be repeated.

	3555803	9:00-9:55	MW	Tyler D	SAC W-107	Full Semester
	3555807	5:00-5:55pm	TTh	Benson M	SAC W-107	Full Semester
	3555801	6:00-6:55pm	MW	Warren G	SAC W-107	Full Semester

E.S. AEROBIC FITNESS 160, AQUA AEROBICS **1 UNIT**
An aerobic exercise class in water. The program is geared to developing cardiovascular endurance, increasing flexibility and toning muscles. No swimming skills required. May be repeated.

	3556001	11:00-12:25pm	MW	Tyler D	POOL	Full Semester
	3556002	6:00-8:05pm	M	MacDonald R	POOL	Full Semester

E.S. AEROBIC FITNESS 160, AQUA AEROBICS **0.5 UNITS**
An aerobic exercise class in water. The program is geared to developing cardiovascular endurance, increasing flexibility and toning muscles. No swimming skills required. May be repeated.

	3556003	6:30-8:30pm	T	Nutter K	POOL	Full Semester
--	---------	-------------	---	----------	------	---------------

E.S. AEROBIC FITNESS 198, CARDIO PUMP **0.5 UNITS**
Instruction in overall fitness development. This class is designed to incorporate weight lifting into a cardio routine. It develops strength and endurance of all major muscle groups using routines performed to music. Whether you are in shape or out of shape this class will improve your overall fitness level! You choose the weight and work at your own pace. May be repeated.

	3559801	11:00-11:55	MW	Luppani M	SAC W-106	Full Semester
--	---------	-------------	----	-----------	-----------	---------------

EXERCISE SCIENCE AQUATICS

E.S. AQUATICS 201, SWIMMING **1 UNIT**
Instruction and practice in the basic stroke techniques and aquatic safety procedures. May be repeated.

	3580101	9:30-10:55	TTh	Gorrie D	POOL	Full Semester
--	---------	------------	-----	----------	------	---------------

E.S. AQUATICS 201, SWIMMING **0.5 UNITS**
Instruction and practice in the basic stroke techniques and aquatic safety procedures. May be repeated.

W	3580104	9:00-11:05	S	Daniel D	POOL	Full Semester
	3580107	11:00-11:55	TTh	Gorrie D	POOL	Full Semester
	3580103	11:30-1:35pm	F	Argo R	POOL	Full Semester
	3580106	4:55-7:00pm	Th	Gorrie D	POOL	Full Semester

E.S. AQUATICS 206, LAP SWIMMING **1 UNIT**
Individualized program designed to improve swimming techniques and endurance. May be repeated. Grade: CR/NCR only. Prerequisite: Student must demonstrate swimming skills.

	3580601	9:30-10:55	TTh	Gorrie D	POOL	Full Semester
--	---------	------------	-----	----------	------	---------------

E.S. AQUATICS 206, LAP SWIMMING **0.5 UNITS**
Individualized program designed to improve swimming techniques and endurance. May be repeated. Grade: CR/NCR only. Prerequisite: Student must demonstrate swimming skills.

W	3580602	9:00-11:05	S	Daniel D	POOL	Full Semester
	3580604	11:00-11:55	TTh	Gorrie D	POOL	Full Semester
	3580606	11:30-1:35pm	F	Argo R	POOL	Full Semester
	3580605	4:55-7:00pm	Th	Gorrie D	POOL	Full Semester

EXERCISE SCIENCE FITNESS

PERSONAL FITNESS EVALUATION

ALL STUDENTS MUST ATTEND AN ORIENTATION
SANTA ANA COLLEGE
Room E-108, (714) 564-6946

ORIENTATIONS GIVEN DURING FIRST WEEK OF INSTRUCTION ONLY

Mon/Tu/Wed/Th/Fri 9am
Mon/Tu/Wed/Th 6pm

Mini Semester Orientations given during
the first week of the mini semester
Mon/Tu/Wed only at 9am AND 6pm

Open hours AFTER Orientation Week are:
Mon-Fri 8-11am & Mon-Thurs 6-9pm

This class offers individual testing as follows: Resting Electrocardiogram, pulmonary function, flexibility testing, skinfold tests and/or underwater weighing for body fat percent, strength testing, exercise electrocardiogram using a treadmill test. A fitness profile will be given to each student when they complete course requirements. The results will be discussed with each student.

E.S. FITNESS 100, PERSONAL FITNESS EVALUATION **0.5 UNITS**
Personal evaluation of your fitness level. Each student completes appointments that evaluate flexibility, strength, blood pressure, body composition, pulmonary function resting electrocardiogram and a graded exercise test. Students are also required to record 20 hours of exercise outside of class. Outside hours must be completed and supervised at an exercise science facility at the college where the student is enrolled. Designed for students without heart problems. May be repeated. Grade: CR/NCR only.

\$5.00 material fee required for this course at registration.

3590001	Hrs Arr	Sneddon D	SAC E-108	Full Semester
3590002	Hrs Arr	Sneddon D	SAC E-108	4/14-6/8
3590003	Hrs Arr	Sneddon D	SAC E-108	1/2-2/1

(Tckt No 3590003: Mandatory orientation Wed, Jan 2, 6pm OR
Thurs, Jan 3, 9am, SAC E-108)

E.S. FITNESS 101, PERSONAL FITNESS EVALUATION **1 UNIT**
Personal evaluation of your fitness level. Each student completes appointments that evaluate flexibility, strength, blood pressure, body composition resting electrocardiogram and a graded exercise test. Students are also required to record 44 hours of exercise outside of class. Outside hours must be completed and supervised at an exercise science facility at the college where the student is enrolled. Designed for students without heart problems. May be repeated. Grade: CR/NCR only.

\$5.00 material fee required for this course at registration.

3590102	Hrs Arr	Jones G	SAC WEB	Full Semester
3590101	Hrs Arr	Sneddon D	SAC E-108	Full Semester

E.S. FITNESS 102, PERSONAL FITNESS EVALUATION **2 UNITS**
Personal evaluation of your fitness level. Each student completes appointments that evaluate flexibility, strength, blood pressure, body composition, pulmonary function resting electrocardiogram and a graded exercise test. Students are also required to record 92 hours of exercise outside of class. Outside hours must be completed and supervised at an exercise science facility at the college where the student is enrolled. Designed for healthy individuals with no heart problems. May be repeated. Grade: CR/NCR only.

\$5.00 material fee required for this course at registration.

3590201	Hrs Arr	Sneddon D	SAC E-108	Full Semester
---------	---------	-----------	-----------	---------------

Do you like, play or watch sports?



SPORTS AND SOCIETY

ESPR 150

On-Line Class (no campus meetings)

Learn the role sports play in our society.

3 Units. Transferable course.
Satisfies Plan A Area D-2 & Plan B Area D-7

TKT#	TIME	DAYS	INSTRUCTOR	LOC./RM.	DATES
------	------	------	------------	----------	-------

CIRCUIT TRAINING

ATTENDANCE

Students are required to attend the Fitness Center a minimum of two times per week for .5 units and a minimum of three times per week for 1 unit. Only one section of 109 or 110 or 115 can be taken per semester.

ORIENTATIONS (New students MUST attend one)

Orientations will begin promptly at 10 am, 12 noon, and 6 pm during operational hours each day of the first two weeks of the semester. No workouts will be permitted during orientation hours.

Mini Semester Orientations given during the first week of the mini semester at the beginning of each hour.

Intersession orientations will be given at 10am, 12 noon and 6pm, Mon, Tues, Wed the first week of Intersession. No workouts will be permitted during orientation hours.

HOURS

The SAC Fitness Center is located in E-102, phone (714) 564-6917.

SAC FITNESS CENTER HOURS: Mon–Th 7am–2pm & 4pm–8pm
 Fri 7am–2pm & 4pm–7pm
 Sat 8am–11am.

E.S. FITNESS 109, CIRCUIT TRAINING		0.5 UNITS	
An individualized program developed to promote lifetime fitness. Employs resistive designed exercise devices for achieving muscle tone while increasing strength and endurance. May be repeated. Grade: CR/NCR only.			
3590901	Hrs Arr	Pagett D	SAC E-102 Full Semester
3590902	Hrs Arr	Pagett D	SAC E-102 4/14-6/8
3590905	Hrs Arr	Luppiani M	SAC E-102 1/2-2/2

E.S. FITNESS 110, CIRCUIT TRAINING		1 UNIT	
An individualized fitness program developed to promote lifetime fitness. Employs resistive designed exercise devices for achieving muscle tone while increasing strength and cardiovascular endurance. May be repeated. Grade: CR/NCR only.			
3591001	Hrs Arr	Pagett D	SAC E-102 Full Semester
3591002	Hrs Arr	Pagett D	SAC W-106 4/14-6/8

E.S. FITNESS 115, CARDIOVASCULAR CONDITIONING		1 UNIT	
Designed for those people who desire a cardiovascular workout using a combination of equipment such as stationary bikes, ellipticals, steppers and rowing machines. Suited for individuals of all age groups interested in maximal cardiovascular fitness. May be repeated. Grade: CR/NCR only.			
3591501	Hrs Arr	Pagett D	SAC E-102 Full Semester

STRENGTH LAB

ATTENDANCE

Students are required to attend the Strength Lab a minimum of two times per week for .5 units and a minimum of three times per week for 1 unit.

ORIENTATION All new students must attend an orientation given on the hour during times listed below.

HOURS

The SAC Strength Lab is located in G-103, phone (714) 564-6907.

SAC STRENGTH LAB HOURS: Mon – Sat 8–12pm, Mon – Thurs 5–7pm

E.S. FITNESS 119, STRENGTH LAB		0.5 UNITS	
Instruction in free weight techniques, using barbells and dumbbells. For those with experience in weight training. Open laboratory. May be repeated. Grade: CR/NCR only.			
3591901	Hrs Arr	Ogas D	SAC G-103 Full Semester
3591902	Hrs Arr	Ogas D	SAC G-103 4/14-6/8
3591903	Hrs Arr	Ogas D	SAC G-103 1/2-2/1

E.S. FITNESS 120, STRENGTH LAB		1 UNIT	
Instruction in free weight techniques, using barbells and dumbbells. For those with experience in weight training. Open laboratory. May be repeated. Grade: CR/NCR only.			
3592001	Hrs Arr	Ogas D	SAC G-103 Full Semester
3592002	Hrs Arr	Ogas D	SAC G-103 4/14-6/8

TKT#	TIME	DAYS	INSTRUCTOR	LOC./RM.	DATES
------	------	------	------------	----------	-------



E.S. FITNESS 145, WEIGHT TRAINING FOR WOMEN		1 UNIT	
An exercise and fitness program designed to improve the student's strength through the use of free weights. Emphasis will be on the development of muscular strength and endurance and overall physical fitness. May be repeated.			
3594501	12:00-1:25pm	TTh	Luppiani M SAC G-103 Full Semester

E.S. FITNESS 147, WEIGHT TRAINING CO-ED		1 UNIT	
Introductory instruction and practice in large muscle area development utilizing free weight. Development will be in muscle size or tone and strength or endurance. May be repeated.			
3594702	6:30am-8:00	MTWTh	Wright J POOL 1/2-2/6
3594703	12:30-1:55pm	MW	Sneddon D SAC G-114 Full Semester
(This class is designed for Intercollegiate Athletic students. Open to all students.)			
3594704	1:00-2:25pm	MW	Luppiani M SAC G-114 Full Semester
3594707	2:00-3:25pm	TTh	Breig D SAC G-114 Full Semester
3594701	2:30-3:55pm	TTh	Gonzales F SAC E-102 Full Semester

E.S. FITNESS 170, YOGA		1 UNIT	
An exercise program involving postures to increase flexibility and core muscle strength as a way of improving and enhancing physical and mental alertness. May be repeated.			
3597004	11:30-12:55pm	TTh	Nutter K SAC W-106 Full Semester

E.S. FITNESS 170, YOGA		0.5 UNITS	
An exercise program involving postures to increase flexibility and core muscle strength as a way of improving and enhancing physical and mental alertness. May be repeated.			
	3597003	8:00-10:05	S Reily C SAC W-107 Full Semester
	3597002	9:00-9:55	TTh Ward M SAC W-111 Full Semester
	3597001	7:00-9:05pm	Th Reily C SAC W-107 Full Semester

EXERCISE SCIENCE HEALTH EDUCATION

E.S. HEALTH EDUCATION 101, HEALTHFUL LIVING		3 UNITS	
A comprehensive look at factors that impact people's health, longevity and lifetime wellness. Areas covered will be personal fitness, nutrition, drugs, alcohol and tobacco, AIDS and sexually transmitted diseases and degenerative diseases including cancer, heart disease, strokes and diabetes.			
	3610105	3 Hrs Arr	Breig D SAC WEB Full Semester
(Email the instructor first week of class. See Online Courses page in class schedule or go to www.sac.edu/disted for more information.)			
	3610103	9:30-10:55	TTh Siddons A SAC F-103 Full Semester
	3610106	11:15-12:40pm	MW Abbey T SAC F-102 Full Semester
	3610101	11:15-12:40pm	TTh Abbey T SAC F-102 Full Semester
	3610104	6:00-9:10pm	T Siddons A SAC F-103 Full Semester
	3610102	Hrs Arr	Breig D SAC WEB 1/2-2/2
(Email the instructor first week of class. See Online Courses page in class schedule or go to www.sac.edu/disted for more information.)			
	3610107	Hrs Arr	Breig D SAC WEB 4/14-6/7
(See Online Courses page in class schedule or go to www.sac.edu/disted for more information.)			

Learn! Workout!
Satisfy GE requirements!

Take these two courses

ES Health Education 104
Nutrition & Fitness 2 units

AND

ES Fitness 100 or 110 **or**
ES Aerobic Fitness 150 or 155
.5 –1 unit – exercise classes

Meet your General
Education Requirements

3 units:

Area F1 & F2 (Plan A) • Area E1 & E2 (Plan B)

TKT#	TIME	DAYS	INSTRUCTOR	LOC./RM.	DATES
------	------	------	------------	----------	-------

E.S. HEALTH EDUCATION 102, WOMEN'S HEALTH ISSUES 3 UNITS

Health topics of concern to women including nutrition, fitness, weight control, violence towards women, sexual health, contraception and other chronic diseases of special concern to women.

3610201	Hrs Arr		Doty A	SAC WEB	Full Semester
(See Online Courses page in class schedule or go to www.sac.edu/disted for more information.)					

E.S. HEALTH EDUCATION 104, NUTRITION AND FITNESS 2 UNITS

An applied nutrition course facilitating a basic understanding of nutrition and fitness concepts. The course will focus on disease prevention, weight control, nutritional analysis and physical fitness assessment and exercise program development.

3610401	10:00-10:55	TTh	Abbey T	SAC F-102	Full Semester
3610402	10:00-11:00	MW	MacDonald J	SAC F-103	Full Semester
3610403	7:00-9:05pm	W	MacDonald J	SAC F-102	Full Semester

E.S. HEALTH EDUCATION 105, FIRST AID & PERSONAL SAFETY 1.5 UNITS

Instruction in accident prevention and immediate care to accident victims. Certificate available upon successful completion. Prepares student for E.S. Health Education 106. May be repeated.

3610501	9:40-11:05	TTh	Gorrie R	SAC G-107	2/11-4/3
---------	------------	-----	----------	-----------	----------

E.S. HEALTH EDUCATION 107, CARDIOPULMONARY RESUSCITATION 2 UNITS

Instruction in artificial respiration and manual artificial circulation, including Automatic External Defibrillator (AED) training. May be repeated.

3610701	7:30am-9:35	TTh	Gorrie R	SAC G-107	2/12-4/3
3610702	9:30-11:35	TTh	Gorrie R	SAC G-107	4/15-6/5
3610704	6:00-9:40pm	W	Sneddon D	SAC G-107	2/11-4/14

EXERCISE SCIENCE INTERCOLLEGIATE ATHLETICS

E.S. INTERCOLLEGIATE ATHLETICS 124, CONDITIONING FOR ATHLETES-MEN 1 UNIT

An exercise program designed for athletes who participate in men's sports. Emphasis will be on the development of speed, endurance, flexibility, and strength. May be repeated.

3632405	9:00-11:30	MTWThF	Gorrie R	SOCC FLD	1/2-2/1
3632403	1:00-3:45pm	MTWThF	Siddons A	TRCK FLD	1/2-2/1
3632404	3:00-5:30pm	MTWThF	Sneddon D	BSBL FLD	1/2-2/1
3632402	4:15-6:45pm	MTWThF	Breig D	SAC G-105	1/2-2/1

E.S. INTERCOLLEGIATE ATHLETICS 124, CONDITIONING FOR ATHLETES-WOMEN 0.5 UNITS

An exercise program designed for athletes who participate in men's sports. Emphasis will be on the development of speed, endurance, flexibility, and strength. May be repeated.

3632407	6:30am-7:25	MW	Wright J	POOL	2/11-6/6
---------	-------------	----	----------	------	----------

E.S. INTERCOLLEGIATE ATHLETICS 126, UPPER BODY DEVELOPMENT FOR ATHLETES-MEN 1 UNIT

An exercise program designed for football athletes who participate in intercollegiate athletics. Emphasis will be on the development of the upper body. Targeted muscle groups are the biceps, triceps, pectorals, deltoids, and the trapezius. May be repeated.

3632601	12:55-3:00pm	TTh	Shine C	SAC G-103	Full Semester
---------	--------------	-----	---------	-----------	---------------

E.S. INTERCOLLEGIATE ATHLETICS 127, LOWER BODY DEVELOPMENT FOR ATHLETES-MEN 1 UNIT

An exercise program designed for football athletes who participate in intercollegiate athletics. Emphasis will be on the development of the lower body. Targeted muscle groups are the gluteus, quadriceps, hamstrings and the calf. May be repeated.

3632701	12:55-3:00pm	MW	Shine C	SAC G-103	Full Semester
---------	--------------	----	---------	-----------	---------------

FIRST AID - ESHE105

- Be prepared when confronted with injuries or sudden illness.
- Learn First Responder Care.

CPR - ESHE107

- For the Professional Rescuer.
- Adult • Child • Infant • AED
- One and Two-Man Rescues.
- Airway obstruction for adult, child, infant.

Both classes recommended for all Nursing, EMT, Fire and Police Science, Teaching, and Human Services students.



TKT#	TIME	DAYS	INSTRUCTOR	LOC./RM.	DATES
------	------	------	------------	----------	-------

Healthful Living

HEALTH EDUCATION 101

MEETS GENERAL EDUCATION AND AA DEGREE REQUIREMENTS

- Learn more about:
- Fitness • Nutrition • AIDS
 - Drugs, Alcohol, Tobacco
 - Sexually Transmitted Diseases

E.S. INTERCOLLEGIATE ATHLETICS 128, CONDITIONING FOR ATHLETES-WOMEN 1 UNIT

An exercise program designed for athletes who participate in women's sports. Emphasis will be on the development of speed, endurance, flexibility and strength. May be repeated.

3632802	1:30-4:00pm	MTWThF	Luppani M	SAC G-105	1/2-2/1
3632803	3:00-6:00pm	MTWThF	Clingan J	TRCK FLD	1/2-2/1

E.S. INTERCOLLEGIATE ATHLETICS 128, CONDITIONING FOR ATHLETES-WOMEN 0.5 UNITS

An exercise program designed for athletes who participate in women's sports. Emphasis will be on the development of speed, endurance, flexibility, and strength. May be repeated.

3632807	6:30am-7:25	MW	Wright J	POOL	2/11-6/6
3632806	3:00-4:25pm	MW	Carmona M	SFTB FLD	2/11-6/6

E.S. INTERCOLLEGIATE ATHLETICS 150, THEORY OF SOCCER 2 UNITS

History and development of soccer. Emphasis on the tactical aspects of the game. May be repeated.

3635002	3:00-5:10pm	MW	Coffman J	SAC G-107	2/11-4/2
3635001	4:00-4:55pm	MW	Vasquez J	SAC F-102	Full Semester

E.S. INTERCOLLEGIATE ATHLETICS 160, THEORY OF SOFTBALL 2 UNITS

A general overview of rules, regulations, strategies, mental preparation, skill evaluation and the history of the sport of softball. May be repeated.

3636001	1:00-2:35pm	MTWThF	Carmona M	SAC F-102	1/2-2/1
---------	-------------	--------	-----------	-----------	---------

E.S. INTERCOLLEGIATE ATHLETICS 180, THEORY OF TRACK AND FIELD 2 UNITS

Designed for the competitive track and field athlete. Students will be introduced to the strategies and tactics of competition in track and field events. Psychological considerations, biomechanics, and a historical perspective of each event will be addressed. May be repeated.

3638001	12:30-1:25pm	TTh	Siddons A	SAC F-103	Full Semester
---------	--------------	-----	-----------	-----------	---------------

E.S. INTERCOLLEGIATE ATHLETICS 201, BASEBALL-MEN 2 UNITS

The program provides competition with conference colleges as well as with other California Community Colleges. Students must meet C.O.A. eligibility requirements and pass a health screening prior to intercollegiate competition. May be repeated.

3640101	2:00-4:05pm	MTWThF	Sneddon D	BSBL FLD	Full Semester
---------	-------------	--------	-----------	----------	---------------

E.S. INTERCOLLEGIATE ATHLETICS 202, BASKETBALL-MEN 1 UNIT

The program provides competition with conference colleges as well as with other California Community Colleges. Students must meet C.O.A. eligibility requirements and pass a health screening prior to intercollegiate competition. May be repeated.

3640201	4:50-7:00pm	MTWThF	Breig D	SAC G-105	2/11-4/4
---------	-------------	--------	---------	-----------	----------

E.S. INTERCOLLEGIATE ATHLETICS 205, GOLF-MEN 2 UNITS

The program provides competition with conference colleges as well as with other California community colleges. Students must meet C.O.A. eligibility requirements and pass a health screening prior to intercollegiate competition. May be repeated.

3640501	2:00-5:30pm	MWF	Gorrie R	SOCC FLD	Full Semester
---------	-------------	-----	----------	----------	---------------

E.S. INTERCOLLEGIATE ATHLETICS 206, SWIMMING-MEN 2 UNITS

The program provides competition with conference colleges as well as with other California community colleges. Students must meet C.O.A. eligibility requirements and pass a health screening prior to intercollegiate competition. May be repeated.

3640601	12:30-2:35pm	MTWThF	Billich J	POOL	Full Semester
---------	--------------	--------	-----------	------	---------------

Can't find the class you need?

It may be waiting for you at Santiago Canyon College!

View SCC's class schedule at www.sccollege.edu/schedule

SCC's class schedule is included in this booklet.

Hurry! Class sizes are limited.

TKT#	TIME	DAYS	INSTRUCTOR	LOC./RM.	DATES
------	------	------	------------	----------	-------

E.S. INTERCOLLEGIATE ATHLETICS 208, TRACK AND FIELD-MEN 2 UNITS

The program provides competition with conference colleges as well as with other California community colleges. Students must meet C.O.A. eligibility requirements and pass a health screening prior to intercollegiate competition. May be repeated.

3640801 1:30-3:05pm MTWThF Siddons A TRCK FLD Full Semester

E.S. INTERCOLLEGIATE ATHLETICS 211, SOFTBALL-WOMEN 2 UNITS

The program provides competition with conference colleges as well as with other California Community Colleges. Students must meet C.O.A. eligibility requirements and pass a health screening prior to intercollegiate competition. May be repeated.

3641101 1:00-3:00pm MTWThF Carmona M SFTB FLD Full Semester

E.S. INTERCOLLEGIATE ATHLETICS 212, BASKETBALL-WOMEN 1 UNIT

The program provides competition with conference colleges as well as with other California Community Colleges. Students must meet C.O.A. eligibility requirements and pass a health screening prior to intercollegiate competition. May be repeated.

3641201 2:40-4:50pm MTWThF Luppiani M SAC G-105 2/11-4/4

E.S. INTERCOLLEGIATE ATHLETICS 215, TENNIS-WOMEN 2 UNITS

The program provides competition with conference colleges as well as with other California community colleges. Students must meet C.O.A. eligibility requirements and pass a health screening prior to intercollegiate competition. May be repeated.

3641501 2:00-4:00pm MTWThF Manuel R TENN CRTS Full Semester

3641502 Hrs Arr Manuel R TENN CRTS Full Semester

E.S. INTERCOLLEGIATE ATHLETICS 217, SWIMMING-WOMEN 2 UNITS

This program provides competition with conference colleges as well as with other California Community Colleges. Students must meet C.O.A. eligibility requirements and pass a health screening prior to intercollegiate competition. May be repeated.

3641702 12:30-2:35pm MTWThF Wright J POOL Full Semester

E.S. INTERCOLLEGIATE ATHLETICS 218, TRACK AND FIELD-WOMEN 2 UNITS

The program provides competition with conference colleges as well as with other California community colleges. Students must meet C.O.A. eligibility requirements and pass a health screening prior to intercollegiate competition. May be repeated.

3641801 2:45-4:45pm MTWThF Clingan J TRCK FLD Full Semester

3641802 Hrs Arr Clingan J TRCK FLD Full Semester

E.S. INTERCOLLEGIATE ATHLETICS 222, BADMINTON-WOMEN 2 UNITS

The program provides competition with conference colleges as well as with other California Community Colleges. Students must meet C.O.A. eligibility requirements and pass a health screening prior to intercollegiate competition. May be repeated.

3642201 12:35-2:50pm TTh Ogas D SAC G-105 Full Semester

AND 3:00-6:00pm WF Ogas D SAC G-105

E.S. INTERCOLLEGIATE ATHLETICS 235, ADVANCED BASEBALL GAME SKILLS 1 UNIT

This course is designed to prepare the student for intercollegiate competition. Students will learn offensive skills, defensive skills and communication under competitive game conditions. May be repeated.

W 3643501 3:00-6:10pm S Sneddon D BSBL FLD Full Semester

EXERCISE SCIENCE OFF SEASON ACTIVITIES

E.S. OFF SEASON ACTIVITIES 130, OFF SEASON SWIMMING 1 UNIT

An advanced aquatics class designed for students with exceptional swimming talent who have an interest in training for competitive swimming. May be repeated.

3653001 2:00-3:30pm MTWTh Wright J POOL 1/2-2/6

E.S. OFF SEASON ACTIVITIES 132, GOLF-PLAYING LESSON 1 UNIT

Applies advanced techniques of golf play on a regulation course. May be repeated.

3653201 3:00-6:10pm T Olsen K RIVE GOLF Full Semester

E.S. OFF SEASON ACTIVITIES 169, WRESTLING 1 UNIT

Fundamentals of wrestling skills and techniques. May be repeated.

3656901 7:00-10:05pm MW Silva V SAC W-111 4/14-6/4

E.S. OFF SEASON ACTIVITIES 226, WATERPOLO 1 UNIT

Instruction and experience in the fundamentals and strategies of water polo. May be repeated.

3662601 7:00-10:10pm W Billish J POOL Full Semester

OR 4:30-7:00pm W Martinez G POOL

(Intended for students training for the men's water polo team)

STUDENTS: Web access to student records and registration is on its way!
Go to www.sac.edu – click on online records and update your student profile with your personal email address.
We'll be in touch.

TKT#	TIME	DAYS	INSTRUCTOR	LOC./RM.	DATES
------	------	------	------------	----------	-------



LEARN HOW TO BALANCE THE
MIND AND BODY...

"SPORT PSYCHOLOGY"

"EXERCISE SCIENCE PROFESSIONAL 125" — 3 UNITS

Psychology majors can use it for an elective

Satisfies Area E requirement for Associate Degree

Transferable course

ANY QUESTIONS CALL COACH COFFMAN 564-6924

E.S. OFF SEASON ACTIVITIES 230, FOOTBALL 1 UNIT

Basic elements of the game including fundamental skills in stance, lateral movement, and throwing. Offensive and defensive play will be practiced. May be repeated.

3663001 3:00-6:10pm TTh Jones G SOCC FLD 3/25-5/22

E.S. OFF SEASON ACTIVITIES 261, SOCCER-WOMEN 1 UNIT

A high-level, competitive, practice and skills program in soccer for athletes with exceptional athletic talent. May be repeated.

3666101 3:00-6:05pm MW Coffman J SOCC FLD 4/14-6/6

E.S. OFF SEASON ACTIVITIES 262, SOCCER-MEN 1 UNIT

A high-level, competitive, practice and skills program in soccer for athletes with exceptional athletic talent. May be repeated.

3666201 5:00-7:05pm MWF Vasquez J SOCC FLD 4/14-6/6

E.S. OFF SEASON ACTIVITIES 290, VOLLEYBALL 1 UNIT

A high-level, competitive conditioning and skills program in volleyball for students with exceptional talent. May be repeated.

3669001 3:00-4:25pm TTh Abbey T SAC W-107 Full Semester

EXERCISE SCIENCE PROFESSIONAL

E.S. PROFESSIONAL 125, SPORT PSYCHOLOGY 3 UNITS

An examination of the psychological aspects of sport concentrating on the scientifically proven methods of enhancing athletic performance through psychological training.

W 3672501 Hrs Arr Coffman J SAC WEB Full Semester

(Mandatory on campus meetings: Every Mon, Feb 11-Jun 6, 11:15am-12:40pm, SAC G-107.

See online courses page in class schedule or go to www.sac.edu/disted for more information.)

E.S. PROFESSIONAL 150, SPORT AND SOCIETY 3 UNITS

Examines the role of sport in modern society. Looks at how sport influences and shapes global attitudes among nations. Investigates the historical, social, economic and political impact of sport on society.

W 3675002 Hrs Arr Luppiani M SAC WEB Full Semester

(See online courses page in class schedule or go to www.sac.edu/disted for more information.)

E.S. PROFESSIONAL 198, MANAGEMENT OF PHYSICAL EDUCATION AND SPORT 3 UNITS

This course examines all aspects of sports administration including the management process, organization of interscholastic and intercollegiate sports, human resources, fiscal issues, legal liability, and public relations. The course is intended for students interested in a career in physical education, coaching, fitness or sports administration.

W 3679802 Hrs Arr Siddons A SAC WEB Full Semester

(Email instructor first week of semester. See Online Courses page in class schedule or go to www.sac.edu/disted for more information.)

E.S. PROFESSIONAL 198, FITNESS AND THE PRESCHOOL CHILD 3 UNITS

This course is designed to acquaint early childhood majors, preschool teachers and parents with fitness programming and assessments skills for the preschool age child. The course includes fitness information and techniques for working with children with special needs. May be repeated.

3679801 6:00-9:00pm T Howell A SAC G-107 Full Semester

TKT#	TIME	DAYS	INSTRUCTOR	LOC./RM.	DATES
------	------	------	------------	----------	-------

EXERCISE SCIENCE SPORTS MEDICINE

E.S. SPORTS MEDICINE 101, INTRODUCTION TO SPORTS MEDICINE 3 UNITS

Introduction to the field of sports medicine. Exposure to athletic injuries, taping techniques, immediate treatment, rehabilitation and prevention of athletic injuries. Prerequisite: Concurrent enrollment in E.S. Sports Medicine 150.

3690101	8:00-9:25	TTh	MacDonald R	SAC F-102	Full Semester
---------	-----------	-----	-------------	-----------	---------------

E.S. SPORTS MEDICINE 150, ATHLETIC TRAINING INTERNSHIP 2 UNITS

A laboratory experience in the application of preventative, acute and post-injury treatment of common athletic injuries. Taping skills and use of the therapeutic modalities will be emphasized. Also covered will be the administration and daily functioning of the training room and participating in a hands-on internship under certified athletic trainers. May be repeated. Prerequisite: Must be enrolled concurrently in E.S. Sports Medicine 101.

3695001	9:30-10:55	TTh	MacDonald R	SAC G-102	Full Semester
---------	------------	-----	-------------	-----------	---------------

EXTENDED OPPORTUNITY SERVICES (SEE SPECIAL SERVICES)

FAMILY CONSUMER STUDIES (SEE FASHION DESIGN / NUTRITION)

FASHION DESIGN MERCHANDISING

FASHION DESIGN MERCHANDISING 005, FASHION LABORATORY 0.5-1 UNIT

Supervised use of the fashion laboratory. Lab hours vary by sign-in. Sixteen laboratory hours per 0.5 unit. Open entry/open exit. Grade: CR/NCR only. Prerequisite: Concurrent enrollment in any Fashion Design Merchandising course.

W	3900503	9:00-1:15pm	S	Silvers L	SAC T-201	Full Semester
	3900505	9:30-10:55	MW	Warner K	SAC T-201	Full Semester
	3900504	12:30-2:35pm	MW	Warner K	SAC T-201	Full Semester
	3900502	6:00-8:05pm	Th	Silvers L	SAC T-201	Full Semester

FASHION DESIGN MERCHANDISING 005A, FASHION LABORATORY 0.5-1 UNIT

Advanced level of supervised use of the fashion laboratory. Lab hours vary by sign-in. Sixteen laboratory hours per .5 unit. Open entry/open exit. May be repeated. Grade: CR/NCR only. Prerequisite: Concurrent enrollment in any Fashion Design Merchandising laboratory course.

3900501	12:30-2:35pm	MW	Warner K	SAC T-201	Full Semester
---------	--------------	----	----------	-----------	---------------

FASHION DESIGN MERCHANDISING 053, INTRODUCTION TO SEWING 2 UNITS

Learn to sew; how to use the sewing machine, understanding pattern terms and tools in constructing basic samples, skirts, and shirts. May be repeated. Grade: CR/NCR only.

W	3905301	9:00-11:05	S	Silvers L	SAC T-201	Full Semester
	3905304	12:30-2:35pm	MW	Warner K	SAC T-201	Full Semester
	3905303	5:45-10:00pm	M	Weller L	SAC T-201	Full Semester
	3905302	5:45-10:00pm	Th	Silvers L	SAC T-201	Full Semester

FASHION DESIGN MERCHANDISING 055, CHILDREN'S CLOTHING 2 UNITS

Quick basic sewing techniques. Emphasis on individualizing designs to create a variety of functional, durable children's garments. May be repeated.

3905501	6:00-8:55pm	Th	Silvers L	SAC T-201	Full Semester
---------	-------------	----	-----------	-----------	---------------

FASHION DESIGN MERCHANDISING 059, FASHION MODELING 1 UNIT

Modeling techniques of the formal fashion runway and informal showings, stressing preparation of the professional model. May be repeated. Grade: CR/NCR only.

3905901	6:30-9:00pm	W	Doumani R	SAC T-201	2/27-5/28
---------	-------------	---	-----------	-----------	-----------

FASHION DESIGN MERCHANDISING 102, PROMOTION AND COORDINATION 2 UNITS

A study of the directing and coordination of event promotions. Emphasis on promotion planning and presentation, salesmanship and show production. May be repeated.

3910201	9:30-11:25	TTh	Warner K	SAC T-201	Full Semester
---------	------------	-----	----------	-----------	---------------

FASHION DESIGN MERCHANDISING 104, TEXTILE FIBERS & FABRICS (CAN FSC 6) 3 UNITS

Textile fiber and fabrics selection, identification, use and care for wearing apparel and home furnishings.

3910401	11:30-12:55pm	TTh	Warner K	SAC T-201	Full Semester
---------	---------------	-----	----------	-----------	---------------

FASHION DESIGN MERCHANDISING 105B, INTERMEDIATE SEWING 2 UNITS

Follow-up of Fashion Design Merchandising 053 and 105A, Beginning Sewing. Coordination of woven fabrics and pattern fitting in construction of class projects such as pants, dress shirts, and unlined jackets. Grade: CR/NCR only.

W	3910501	9:00-1:00pm	S	Silvers L	SAC T-201	Full Semester
	3910502	12:30-2:35pm	MW	Warner K	SAC T-201	Full Semester

TKT#	TIME	DAYS	INSTRUCTOR	LOC./RM.	DATES
------	------	------	------------	----------	-------

FASHION DESIGN MERCHANDISING 106A, ADVANCED SEWING I 1.5 UNITS

Follow-up of Fashion Design Merchandising 105B, Intermediate Sewing. Student will learn to refine sewing techniques to use complex designer patterns and challenging fabrics to construct custom garments and couture gowns.

3910601	12:30-2:35pm	MW	Warner K	SAC T-201	Full Semester
---------	--------------	----	----------	-----------	---------------

FASHION DESIGN MERCHANDISING 112, PATTERN DRAFTING 3 UNITS

Flat pattern drafting techniques applied to completing basic blocks and first patterns for pants and lined blazers/coats. Students are required to sew their sample garments. Suggested preparation: Fashion Design Merchandising 053 or 105A and 105B.

3911201	9:30-11:40	TTh	Warner K	SAC T-201	Full Semester
---------	------------	-----	----------	-----------	---------------

FASHION DESIGN MERCHANDISING 125, DISPLAY MERCHANDISING 3 UNITS

Visual merchandise techniques and material in relation to the elements and principles of design.

3912501	5:45-10:00pm	T	Coury R	SAC T-201	Full Semester
---------	--------------	---	---------	-----------	---------------

FASHION DESIGN MERCHANDISING 213, APPAREL LINE PRODUCTION 2 UNITS

Instruction on designing a line using industry production techniques and equipment, from sketch, pattern through construction. Prerequisite: Fashion Design Merchandising 100 or 108, and 109 and 111A with a grade of C or better.

3921302	9:30-10:55	MW	Warner K	SAC T-201	Full Semester
---------	------------	----	----------	-----------	---------------

FASHION DESIGN MERCHANDISING 215, COMPUTER FASHION ILLUSTRATION 1 UNIT

Computer fashion illustration is taught using Lectra computer software. Student needs to know how to manually draw trade flats and posed figures prior to enrolling. Suggested preparation: Fashion Design Merchandising 111A. May be repeated.

W	3921501	9:00-1:15pm	S	Silvers L	SAC T-201	4/19-6/7
---	---------	-------------	---	-----------	-----------	----------

FASHION DESIGN MERCHANDISING 216, COMPUTER PATTERN DESIGN, GRADING AND MARKING 1 UNIT

Computerized apparel pattern drafting, size grading and marking are taught using Lectra Modaris and Diamino computer software as tools. Prior to enrollment, student must be able to manually draft patterns, grade patterns and layout markers. Suggested preparation: Fashion Design Merchandising 109 and 214. May be repeated.

3921601	5:45-10:00pm	Th	Silvers L	SAC T-201	2/14-4/3
---------	--------------	----	-----------	-----------	----------

FASHION DESIGN MERCHANDISING 299, COOPERATIVE WORK EXPERIENCE EDUCATION 1-4 UNITS

Supervised paid or volunteer experience in fashion including new or expanded responsibilities. Must enroll in 7 units. Limit 16 units in Cooperative Education courses. Students must attend ONE orientation meeting. May be repeated. Grade: CR/NCR only. Prerequisite: 12 units of Fashion Design Merchandising courses.

3929902	1:35-2:40pm	T	Warner K	SAC T-201	Full Semester
---------	-------------	---	----------	-----------	---------------

REGISTER EARLY—SPACE IS LIMITED

Fashion Design or Merchandising



Certificate or AA Degree Programs

NEW STUDENTS REGISTER FOR:

FDM 102, Promotion & Coordination
FDM 104, Textile Fabrics
FDM 125, Display Merchandising

NEW DESIGN STUDENTS ALSO TAKE:

FDM 005, Fashion Lab
FDM 053, Basic Sewing (if non-sewer)
or FDM 105B, Intern. or 106 Adv. Sewing
FDM 112, Pattern Drafting

EXPERIENCED STUDENTS / INDUSTRY WORKERS:

Computer classes on Lectra System!

FDM 215, 216

FDM 213, Apparel Line

FDM 106, Advanced Sewing

See your catalog or
call (714) 564-6800
for more information

TKT#	TIME	DAYS	INSTRUCTOR	LOC./RM.	DATES
------	------	------	------------	----------	-------

FIRE ACADEMY

Academic prerequisite clearance required prior to class enrollment at office, SAC A-113. Academy courses are designed to articulate with the California Fire Academy Program, 714-564-6845.

FIRE ACADEMY 008, FIREFIGHTER I PHYSICAL ABILITY EXAMINATION					0.1 UNITS
Designed to assess physical ability requirements. May be repeated. Grade: CR/NCR only.					
4000810	7:30am-11:30	Su	Bartlett M	JPTC CN	1/27-1/27
4000812	7:30am-11:30	Su	Bartlett M	JPTC CN	3/2-3/2
4000814	7:30am-11:30	Su	Bartlett M	JPTC CN	3/23-3/23
4000816	7:30am-11:30	Su	Bartlett M	JPTC CN	4/27-4/27
4000818	7:30am-11:30	Su	Bartlett M	JPTC CN	5/18-5/18
4000820	7:30am-11:30	Su	Bartlett M	JPTC CN	6/8-6/8
4000811	12:30-4:30pm	Su	Bartlett M	JPTC CN	1/27-1/27
4000813	12:30-4:30pm	Su	Bartlett M	JPTC CN	3/2-3/2
4000815	12:30-4:30pm	Su	Bartlett M	JPTC CN	3/23-3/23
4000817	12:30-4:30pm	Su	Bartlett M	JPTC CN	4/27-4/27
4000819	12:30-4:30pm	Su	Bartlett M	JPTC CN	5/18-5/18
4000821	12:30-4:30pm	Su	Bartlett M	JPTC CN	6/8-6/8

Basic Fire Academy

Steps a student must complete to enter the Placement Session for the Basic Fire Academy

- 1 It is recommended that you attend a Fire Technology Orientation — call Counseling to make an appointment, (714) 564-6100.
- 2 Stop by or call the Fire Technology Office (room A-113) and pick up a “Dear Firefighter Candidate” letter, (714) 564-6845 or go to www.sac.edu/fire.
- 3 It is recommended that a Placement test be taken — call the Testing Center to make an appointment, (714) 564-6148.
- 4 Complete the following classes with a “C” or better grade:
 - Recommended first semester
 - Fire Technology 101
 - Fire Technology 102
 - Fire Technology 121*
 - Fire Technology 103*
 - Recommended second semester
 - Fire Technology 104
 - Fire Technology 105
 - Fire Technology 106
 - Fire Academy 008 (Ability Test)*

* may be taken in either semester
- 5 After completing Fire Technology 101, 102, see the Fire Technology Office (A-113) to open “a file.”
- 6 Take and pass a Biddle Validated Physical Ability (Fire Academy 008).
- 7 Verify Placement Session dates with the Fire Technology Office (room A-113).
- 8 You must attend the Placement Session to be placed into an Academy.
- 9 After the placement session, complete a medical exam that meets N.F.P.A. 1582 — make a copy of the results sent to you by the doctor and bring the copy to the Fire Technology Office to be placed in your file.
- 10 Complete an EMT I course and bring proof of completion to the Fire Technology Office, A-113.

TKT#	TIME	DAYS	INSTRUCTOR	LOC./RM.	DATES
------	------	------	------------	----------	-------

FIRE ACADEMY 008B, BEGINNING PHYSICAL ABILITY TRAINING					0.5 UNITS
Specific conditioning exercises prepare student for participation in the 008 Physical Ability class. Students will perform physical exercises using fire hose, ladders, stairs, calisthenics, proper body mechanics, lifting techniques and physical conditioning principles. May be repeated. Grade: CR/NCR only.					
4000830	8:45-10:45	MWF	Argo R	JPTC CN	1/4-1/4
4000842	8:45-10:45	F	Argo R	JPTC CN	2/15-4/4
4000843	8:45-10:45	F	Argo R	JPTC CN	4/18-6/6
4000840	6:00-8:00pm	W	Argo R	JPTC CN	2/13-4/2
4000841	6:00-8:00pm	W	Argo R	JPTC CN	4/16-6/4

FIRE ACADEMY 008C, INTERMEDIATE PHYSICAL ABILITY TRAINING					0.5 UNITS
Specific conditioning exercises prepare students for participation in the 008 Physical Ability class. Students will perform physical exercises using fire hose, ladders, stairs, and calisthenics, proper body mechanics, lifting techniques, and physical conditioning principles. May be repeated. Grade: CR/NCR only.					
4000852	8:45-10:45	F	Argo R	JPTC CN	2/15-4/4
4000853	8:45-10:45	F	Argo R	JPTC CN	4/18-6/6
4000850	6:00-8:00pm	W	Argo R	JPTC CN	2/13-4/2
4000851	6:00-8:00pm	W	Argo R	JPTC CN	4/16-6/4

FIRE ACADEMY 060, BASIC FIRE ACADEMY					12 UNITS
California State Board of Fire Services/Firefighter I approved, criteria available. Prerequisite: Grade C or better in Fire Technology 101, 102, 103, 104, 105, 106, 121; Fire Academy 008, 051; meet NFPA 1582 medical examination, and concurrent enrollment in Fire Academy 007 and 061B.					
4006046	8:00-5:00pm	MTWThF	Staff	JPTC CN	12/17-3/29
4006047	8:00-5:00pm	MTWThF	Staff	JPTC CN	3/11-6/20
4006045	6:00-10:00pm	TTh	Staff	JPTC CN	12/17-5/29
AND	9:00-5:00pm	S	Soltis K	JPTC CN	

FIRE TECHNOLOGY

FIRE TECHNOLOGY 101, FIRE PROTECTION ORGANIZATION					3 UNITS
Survey of the fire service and fire protection; career opportunities; history; fire loss analysis; public, quasi-public and private fire protection; specific fire protection functions; chemistry and physics.					
4210101	8:30-11:40	M	Ash J	SAC A-128	Full Semester
4210102	8:30-11:40	T	Busch M	SAC A-128	Full Semester
4210103	12:00-3:10pm	W	Nelson M	SAC A-128	Full Semester
4210106	12:00-3:10pm	Th	Flint Jr. J	SAC W-101	Full Semester
4210105	7:00-10:10pm	T	Schultz T	SAC W-101	Full Semester
4210144	Hrs Arr		Stefano D	SAC WEB	Full Semester
(See Online Courses page in class schedule or go to www.sac.edu/disted for more information. Email instructor first week of class.)					

FIRE TECHNOLOGY 102, FIRE BEHAVIOR AND COMBUSTION					3 UNITS
Fundamentals and scientific principles of fire behavior, combustible materials, extinguishing agents, hazardous and toxic materials, and fire prevention/suppression techniques.					
4210202	8:00-11:10	F	Treanor M	SAC H-207	Full Semester
4210201	8:30-11:40	W	Nelson M	SAC A-128	Full Semester
4210203	12:00-3:10pm	M	Ash J	SAC A-128	Full Semester
4210204	12:00-3:10pm	T	Busch M	SAC A-128	Full Semester
4210205	3:30-6:40pm	W	Muir J	SAC A-128	Full Semester
4210206	7:00-10:10pm	Th	Treanor M	SAC W-101	Full Semester

FIRE TECHNOLOGY 103, PERSONAL FIRE SAFETY					3 UNITS
Provides career directed students, and/or volunteers, firefighters, and fire brigade members demonstrations on current techniques in the prevention of injuries and promotion of safety while conducting routine and emergency fire operations.					
4210302	8:30-11:40	M	Childress D	SAC W-101	Full Semester
4210301	8:30-11:40	Th	Stefano D	SAC W-101	Full Semester
4210303	12:00-3:10pm	F	Treanor M	SAC H-207	Full Semester
4210305	3:30-6:40pm	M	Hirsch J	SAC A-128	Full Semester
4210306	3:30-6:40pm	T	Hirsch J	SAC H-207	Full Semester
4210304	7:00-10:10pm	W	Samuels M	SAC A-128	Full Semester

FIT FOR FIRE

Here's the solution!!

Fire Academy 008B, Physical Ability Training

This class will give you the specific training and conditioning you need. This eight week course will allow you to train with fire hose, ladders, hose bundles and other necessary equipment. The class will help you to improve on your lifting techniques and overall physical condition. Don't delay! Join today! Enrollment authorization not required for 008B.

TKT#	TIME	DAYS	INSTRUCTOR	LOC./RM.	DATES
------	------	------	------------	----------	-------

FIRE TECHNOLOGY 104, FIRE PREVENTION TECHNOLOGY 3 UNITS

Organization and function of fire prevention; inspections, surveying and procedures, recognition of fire and life hazards; engineering a solution of a fire hazard; enforcing solutions to a fire hazard; public relations as affected by fire prevention. Prerequisite: Fire Technology 101 and 102.

4210403	8:30-11:40	W	Freeman S	SAC W-101	Full Semester
4210402	12:00-3:10pm	T	Freeman S	SAC W-101	Full Semester
4210401	3:30-6:40pm	M	Freeman S	SAC W-101	Full Semester
4210405	7:00-10:10pm	T	Springer B	SAC A-128	Full Semester
4210444	Hrs Arr		Freeman S	SAC WEB	Full Semester

(See Online Courses page in class schedule or go to www.sac.edu/disted for more information. Email instructor first week of class)

FIRE TECHNOLOGY 105, BUILDING CONSTRUCTION FOR FIRE PROTECTION 3 UNITS

The components of building construction that relate to fire safety. Elements of construction and design of structures. The development and evolution of building and fire codes. Prerequisite: Fire Technology 101 and 102.

4210503	3:30-6:40pm	T	Busch M	SAC A-128	Full Semester
4210501	3:30-6:40pm	Th	Harrison K	SAC A-128	Full Semester
4210502	7:00-10:10pm	Th	Harrison K	SAC A-128	Full Semester
4210544	Hrs Arr		Wiskus D	SAC WEB	Full Semester

(See Online Courses page in class schedule or go to www.sac.edu/disted for more information. Email instructor first week of class.)

4210545	Hrs Arr		Wiskus D	SAC WEB	Full Semester
---------	---------	--	----------	---------	---------------

(See Online Courses page in class schedule or go to www.sac.edu/disted for more information. Email instructor first week of class.)

FIRE TECHNOLOGY 106, FIRE PROTECTION EQUIPMENT AND SYSTEMS 3 UNITS

Portable fire extinguishing equipment; protection systems for special hazards; sprinkler systems, fire detection and alarm systems. Prerequisite: Fire Technology 101 and 102.

4210601	8:30-11:40	T	Freeman S	SAC W-101	Full Semester
4210604	12:00-3:10pm	Th	Freeman S	SAC A-128	Full Semester
4210605	7:00-10:10pm	M	Staff	SAC A-128	Full Semester
4210644	Hrs Arr		Wiskus D	SAC WEB	Full Semester

(See Online Courses page in class schedule or go to www.sac.edu/disted for more information. Email instructor first week of class.)

All Fire Technology 121 classes require 16 hours of arranged lab time.

FIRE TECHNOLOGY 121, PHYSICAL FITNESS FOR PUBLIC SAFETY PERSONNEL 4 UNITS

This lecture/laboratory class provides information on exercise and nutrition. Topics include cardiovascular/muscular fitness, injury prevention and treatment. Students will receive an individual fitness profile developed from tests given during the arranged hours of the class.

4212101	8:30-11:40	Th	Bartlett M	SAC A-128	Full Semester
(Students are required to pay \$10 at the first class meeting)					
4212102	8:30-11:40	F	Bartlett M	SAC A-128	Full Semester
(Students are required to pay \$10 at the first class meeting)					
4212103	12:00-3:10pm	M	Argo R	SAC W-101	Full Semester
(Students are required to pay \$10 at the first class meeting)					
4212104	12:00-3:10pm	W	Argo R	SAC H-207	Full Semester
(Students are required to pay \$10 at the first class meeting)					
4212105	7:00-10:10pm	T	Martin D	SAC H-207	Full Semester
(Students are required to pay \$10 at the first class meeting)					
4212106	7:00-10:10pm	Th	Martin D	SAC H-207	Full Semester
(Students are required to pay \$10 at the first class meeting)					

Contact the Fire Technology Office at 714-564-6404 for information about the following programs

To insure open enrollment, class availability and scheduling flexibility while meeting the training needs of the fire service and other public safety agencies, the Fire Technology Department adapts emergency medical technician re-certification classes and firefighter skills in-service classes to the schedules, protocols and rescue practices of specific agencies. Fire Academy 015 and 025 classes require two years of continuous enrollment for successful completion and carry health and safety prerequisites that are designed to protect unprepared students in dangerous training situations.

- CAREER FIREFIGHTER ACADEMY
- CONFINED SPACE RESCUE: OPERATIONAL
- DISASTER RESPONSE FOR EMERGENCY RESPONDERS
- DRIVER OPERATOR ACADEMY
- EMERGENCY TRENCH SHORING
- FIRE CSFA SEMINAR
- ICS-300 INTERMEDIATE ICS
- PUBLIC SAFETY OFFICER
- RECRUIT FIREFIGHTER ACADEMY
- S-290 INTERMEDIATE WILDLAND FIRE BEHAVIOR
- SKILLS ASSESSMENT FOR EMPLOYED FIREFIGHTER I

www.sac.edu

TKT#	TIME	DAYS	INSTRUCTOR	LOC./RM.	DATES
------	------	------	------------	----------	-------

FIRE TECHNOLOGY PROGRAMS

- FIRE ACADEMY 009, BASIC WELLNESS AND FITNESS ASSESSMENT FOR PUBLIC SAFETY PERSONNEL (.2 Units)

For details on times, dates and registration, contact the Fire Technology Office at 714-564-6861.

- FIRE PUBLIC SAFETY 019, ANNUAL TOPICS – FIRE INSERVICE TRAINING (0,5-4 Units)

- FIRE ACADEMY 063, HEAVY RESCUE SYSTEM 2 (.8 Units)
- FIRE ACADEMY 033, SWIFT WATER RESCUE (.5 Units)
- FIRE ACADEMY 035, CONFINED SPACE RESCUE: OPERATIONAL (.8 Units)
- FIRE ACADEMY 034, EMERGENCY TRENCH SHORING (.2 Units)

For details on times, dates and registration, contact the North Net Training Center at 714-978-7304.

- FIRE ACADEMY 030, STRIKE TEAM LEADER-ENGINE (.4 Units)
- FIRE ACADEMY 030, DISASTER RESPONSE FOR EMERGENCY RESPONDERS (.2 Units)
- FIRE ACADEMY 030, URBAN/WILDLAND INTERFACE: SAFETY & TACTICS SEMINAR (.2 Units)

For details on times, dates and registration, contact the Fire Technology Office at 714-564-6404.

- FIRE ACADEMY 063, HEAVY RESCUE SYSTEMS (.8 Units)
- FIRE ACADEMY 083, PROMOTIONAL PREPARATION (.4 Units)

For details on times, dates and registration, contact the Fire Technology Office at 714-564-6404.

- FIRE ACADEMY 231A, FIRE PREVENTION OFFICER 1A (2 Units)
- FIRE ACADEMY 231B, FIRE PREVENTION OFFICER 1B (2 Units)
- FIRE ACADEMY 231C, FIRE PREVENTION 1C (1-2 Units)
- FIRE ACADEMY 232A, FIRE PREVENTION 2A (2 Units)
- FIRE ACADEMY 232B, FIRE PREVENTION 2B (2 Units)
- FIRE ACADEMY 232C, FIRE PREVENTION 2C (2 Units)
- FIRE ACADEMY 241A, FIRE INSTRUCTOR 1A (2 Units)
- FIRE ACADEMY 241B, FIRE INSTRUCTOR 1B (2 Units)
- FIRE ACADEMY 251A, FIRE INVESTIGATION 1A (2 Units)
- FIRE ACADEMY 251B, FIRE INVESTIGATION 1B (2 Units)
- FIRE ACADEMY 261, FIRE MANAGEMENT 1 (2 Units)
- FIRE ACADEMY 262A, FIRE MANAGEMENT 2A (2 Units)
- FIRE ACADEMY 262B, FIRE MANAGEMENT 2B (2 Units)
- FIRE ACADEMY 262C, FIRE MANAGEMENT 2C (2 Units)
- FIRE ACADEMY 262D, FIRE MANAGEMENT 2D (2 Units)
- FIRE ACADEMY 262E, FIRE MANAGEMENT 2E (2 Units)
- FIRE ACADEMY 271A, FIRE COMMAND 1A (2 Units)
- FIRE ACADEMY 271B, FIRE COMMAND 1B (2 Units)
- FIRE ACADEMY 271C, FIRE COMMAND 1C (2 Units)
- FIRE ACADEMY 272A, FIRE COMMAND 2A (2 Units)
- FIRE ACADEMY 272B, FIRE COMMAND 2B (2 Units)
- FIRE ACADEMY 272C, FIRE COMMAND 2C (2 Units)
- FIRE ACADEMY 272D, FIRE COMMAND 2D (2 Units)
- FIRE ACADEMY 273A, FIRE COMMAND 3A (2 Units)
- FIRE ACADEMY 273B, FIRE COMMAND 3B (2 Units)
- FIRE ACADEMY 252A, FIRE INVESTIGATION 2A (2 Units)
- FIRE ACADEMY 252B, FIRE INVESTIGATION 2B (2 Units)
- FIRE ACADEMY 062, ICS 200 (1 Unit)
- FIRE ACADEMY 062B, ICS 300 (1 Unit)
- FIRE ACADEMY 062C, ICS 400 (0.5 Units)

All Fire Officer reservations must be made through the Fire Technology Office, A-113. For details on times, dates and registration, contact the Fire Officer at 714-564-6404.

TKT#	TIME	DAYS	INSTRUCTOR	LOC./RM.	DATES
------	------	------	------------	----------	-------

TKT#	TIME	DAYS	INSTRUCTOR	LOC./RM.	DATES
------	------	------	------------	----------	-------

Can't find the class you need?

**It may be waiting for you at
Santiago Canyon College!**

**View SCC's class schedule at
www.scccollege.edu/schedule**

SCC's class schedule is included in this booklet.

Hurry! Class sizes are limited.

FIRST AID
(SEE E.S. HEALTH EDUCATION)

FOODS
(SEE NUTRITION & FOOD)

FRENCH

FRENCH LANGUAGE CLASSES REQUIRE LAB TIME

FRENCH 101, ELEMENTARY FRENCH 1 (CAN FREN 2) (CAN FREN SEQ A = FREN 101+102)					
					5 UNITS
Basic pronunciation, functional grammar, simple conversation, cultural readings. Laboratory assignments. French 101 is equivalent to two years of high school French.					
4310101	8:00-10:30	MW	Issa K	SAC D-302	Full Semester
4310102	8:00-10:30	TTh	Staff	SAC D-302	Full Semester
4310103	11:00-1:30pm	TTh	Issa K	SAC D-302	Full Semester
4310104	4:15-6:45pm	TTh	Anglin M	SAC D-304	Full Semester
4310105	7:00-9:30pm	MW	Kanatsiz E	SAC D-302	Full Semester

Foreign Language Laboratories are located in SAC D-301 at Santa Ana College and in SCC E-307 at Santiago Canyon College. The labs are open during morning and evening hours for the use of transfer level students. These students are automatically enrolled in French 009 Language Lab for hours exceeding the course requirement.

FRENCH 102, ELEMENTARY FRENCH II					
					5 UNITS
More complex grammar, pronunciation, vocabulary, cultural reading, composition and conversation. Appropriate lab work. French 102 is equivalent to the third year of high school French. Prerequisite: French 101 or two years of high school French with a passing grade.					
4310201	11:00-1:30pm	MW	Issa K	SAC D-302	Full Semester

FRENCH 201, INTERMEDIATE FRENCH I (CAN FREN 8) (CAN FREN SEQ B = FREN 201+202)					
					5 UNITS
A college level French class focusing on conversation, composition; expansive review of usage and grammar. Discussions of history and culture through interpretive readings. Prerequisite: Grade of C or better in French 102 or three years of high school French.					
4320102	4:15-6:45pm	MW	Dannov I	SAC D-302	Full Semester

FRENCH 202, INTERMEDIATE FRENCH II (CAN FREN 10) (CAN FREN SEQ B = FREN 201+202)					
					5 UNITS
A college level French class focusing on conversation, composition, and specialized review of usage and grammar. Discussions of history and culture through literature. Prerequisite: French 201, or four years of high school French with a grade of C or better.					
4320201	4:15-6:45pm	MW	Dannov I	SAC D-302	Full Semester

GEOGRAPHY

GEOGRAPHY 100, WORLD REGIONAL GEOGRAPHY					
					3 UNITS
The study of major world political and natural regions. The location of the regions on earth, the physical and cultural elements which lend the regions their identity, and ways in which the elements relate to the regions' inhabitants and economies.					
4510013	Hrs Arr		Titus J	SAC WEB	Full Semester
<small>(See Online Courses page in class schedule or go to www.sac.edu/disted for more information)</small>					
4510004	8:00-9:25	TTh	Courter W	SAC D-202	Full Semester
4510007	9:45-11:10	MW	Courter W	SAC D-202	Full Semester
4510012	11:30-12:55pm	MW	Courter W	SAC D-202	Full Semester
4510003	1:00-4:35pm	MTWTh	Courter W	SAC D-202	1/8-1/31
4510008	5:30-8:40pm	MW	Staff	SAC D-202	4/14-6/4
4510009	6:00-9:10pm	F	Staff	SAC D-202	4/18-6/7
AND	9:00-12:10pm	S	Staff	SAC D-202	
4510005	7:00-10:10pm	Th	Quinn C	SAC D-202	Full Semester
4510010	Hrs Arr		Titus J	SAC WEB	Full Semester
<small>(See Online Courses page in class schedule or go to www.sac.edu/disted for more information)</small>					

GEOGRAPHY 100H, HONORS WORLD REGIONAL GEOGRAPHY					
					3 UNITS
Enriched and intensive study, including seminar approach with individual written and oral presentations of major world political and natural regions, the location of the regions on earth, the physical and cultural elements which provide the regions their identity, and ways in which these elements relate to the regions' inhabitants and economies. Prerequisite: A high school or college G.P.A. of 3.0 or above.					
4510011	8:00-11:35	MTWTh	Courter W	SAC D-202	1/8-1/31
GEOGRAPHY 101, PHYSICAL GEOGRAPHY (CAN GEOG 2)					
					3 UNITS
Introduction to the physical elements of geography: maps, earth/sun relationships, meteorology and climatology, natural vegetation, soils, and geomorphology.					
4510102	9:45-11:10	TTh	Courter W	SAC D-202	Full Semester
4510106	11:30-12:55pm	TTh	Courter W	SAC D-202	Full Semester
GEOGRAPHY 101L, PHYSICAL GEOGRAPHY LABORATORY					
					1 UNIT
Laboratory exercises and experiments designed to explore and understand the primary areas of physical geography. Exercises and applications related to map scales and projections, stereoscopic, topographic and aerial photo interpretation, meteorological tools and models and weather prognostication, geomorphologic models and processes, and landform interpretation. Prerequisite: Geography 101 or concurrent enrollment.					
4510107	1:15-4:30pm	T	Courter W	SAC D-202	Full Semester
GEOGRAPHY 102, CULTURAL GEOGRAPHY					
					3 UNITS
A survey course including global patterns of population, migration, religion, language, agriculture, politics, customs, resources, urban and rural settlement, and the role of culture within societies and social groups.					
4510201	8:00-9:25	MW	Courter W	SAC D-202	Full Semester

GEOLOGY

GEOLOGY 101, INTRODUCTION TO GEOLOGY (CAN GEOL 6) (CAN GEOL 2 = GEOL 101+101L)					
					3 UNITS
Introductory course for students in any major. Study of the internal and external processes that shape the earth (earthquakes, volcanoes, groundwater, streams, landslides). Concurrent enrollment in Geology 101L is recommended.					
4610181	48 Hrs Arr		Hughes P	SAC TV	Full Semester
<small>(The scheduled on-campus meeting days and times will be held in SAC R-111)</small>					
4610107	9:30-12:20pm	MTWThF	Hughes P	SAC R-111	1/7-2/1
4610101	9:45-11:10	MW	Hughes P	SAC R-111	Full Semester
4610106	9:45-11:10	TTh	Hughes P	SAC R-111	Full Semester
4610104	6:30-9:40pm	M	Coyne C	SAC R-111	Full Semester
GEOLOGY 101L, INTRODUCTION TO GEOLOGY LABORATORY (CAN GEOL 2 = GEOL 101+101L)					
					1 UNIT
Lab course to accompany Geology 101. A study of the common rocks and minerals, and how landscapes are formed and shaped. Prerequisite: Geology 101 or concurrent enrollment.					
4610151	9:30-12:20pm	F	Hughes P	SAC R-111	Full Semester
4610108	1:30-4:20pm	MTWThF	Hughes P	SAC R-111	1/7-2/1
4610154	6:30-9:40pm	W	Coyne C	SAC R-111	Full Semester
GEOLOGY 172, GEOLOGIC FIELD STUDIES OF THE CALIFORNIA COAST					
					2 UNITS
A study of the coastal rocks, fossils and faults, as well as coastal oceanographic processes, from Malibu to Monterey. Mandatory orientation along with a five-day field study. May be repeated.					
4617201	Hrs Arr		Hughes P	SAC R-111	3/27-4/17
<small>(Pre-trip orientation mtg. Thurs, Mar 27, 5:30-6:30pm, SAC R-111. Field trip Mon, Apr 7, 5:30pm to Fri, Apr 11, 9pm. Post-trip mtg. Thurs, Apr 17, 5:30-6:30pm, SAC R-111. This class has outdoor, overnight camping.)</small>					
GEOLOGY 173, GEOLOGIC FIELD STUDIES OF DEATH VALLEY					
					1 UNIT
The geologic history including mountain building, volcanic activity, faulting, mineral resources and human history of the Death Valley region. Mandatory orientation along with a weekend field trip. May be repeated.					
4617301	Hrs Arr		Coyne C	SAC R-111	5/1-5/15
<small>(Pre-trip orientation mtg. Thurs, May 1, 5:30-6:30pm, SAC R-111. Field Trip: Fri, May 9, 5:30pm to Sun, May 11, 9pm. Post-trip mtg. Thurs, May 15, 5:30-6:30pm, SAC R-111. This class has outdoor, overnight camping.)</small>					

Are you interested in tsunamis, volcanoes, earthquakes, and other natural disasters?



Would you like to learn how the earth produces such awesome forces of nature?

You can take Environmental Geology • Geology 140

Meets all general education science requirements for RSCCD, UC, and Cal State.

TKT#	TIME	DAYS	INSTRUCTOR	LOC./RM.	DATES
GEOLOGY 201, INTRODUCTION TO HISTORICAL GEOLOGY (CAN GEOL 4) 4 UNITS					
Introductory geology course suitable for students in any major. Investigates the former landscapes and inhabitants of the Earth as preserved in the rock record with an emphasis on North America. Two optional one-day field trips.					
4620101	7:00-10:10pm	TTh	Hughes P	SAC R-111	Full Semester

**GUIDANCE
(SEE COUNSELING)**

**HEALTH EDUCATION
(SEE EXERCISE SCIENCE)**

HISTORY

HISTORY 101, WORLD CIVILIZATIONS TO THE 16TH CENTURY (CAN HIST 14) (CAN HIST SEQ C = HIST 101+102) 3 UNITS					
The development of world civilizations from the earliest beginnings to the sixteenth century.					
4810104	8:00-9:25	MW	Martin R	SAC D-210	Full Semester
4810105	8:00-9:25	MW	Proffitt, III T	SAC B-4	Full Semester
4810109	8:00-9:25	TTh	Martin R	SAC D-210	Full Semester
4810103	9:45-11:10	TTh	Martin R	SAC D-210	Full Semester
4810106	11:30-12:55pm	MW	Booth B	SAC D-210	Full Semester
4810102	11:30-12:55pm	TTh	McRoberts M	SAC D-204	Full Semester
4810108	6:00-9:35pm	MTWTh	Ghelfi G	SAC D-205	1/8-1/31

HISTORY 101H, HONORS WORLD CIVILIZATIONS TO THE 16TH CENTURY 3 UNITS					
An enriched approach designed for honors students. The development of world civilizations from the earliest beginnings to the sixteenth century. Prerequisite: A high school or college GPA of 3.0 or above.					
4810131	7:00-10:10pm	M	Martin R	SAC D-210	Full Semester

HISTORY 102, WORLD CIVILIZATIONS SINCE THE 16TH CENTURY (CAN HIST 16) (CAN HIST SEQ C = HIST 101+102) 3 UNITS					
The development of world civilizations from the 16th century to the present.					
4812003	9:45-11:10	MW	Martin R	SAC D-210	Full Semester
4810207	7:00-10:10pm	W	Martin R	SAC D-210	Full Semester

HISTORY 118, SOCIAL & CULTURAL HISTORY OF THE UNITED STATES 3 UNITS					
A topical study of the social and cultural forces in American life with emphasis upon American economic, cultural and social transformation.					
4811801	8:00-9:25	TTh	Ghelfi G	SAC D-205	Full Semester
4811802	9:45-11:10	MW	Ghelfi G	SAC D-213	Full Semester
4811803	6:00-9:35pm	MTWTh	Booth B	SAC D-204	1/8-1/31

HISTORY 120, THE UNITED STATES TO 1865 (CAN HIST B = HIST 120+121) (CAN HIST 8) 3 UNITS					
Examines the development of American culture from its earliest European origins to the end of the Civil War.					
4812002	8:00-9:25	MW	Gunther V	SAC D-303	Full Semester
4812005	9:45-11:10	MW	Guzman K	SAC D-103	Full Semester
4812004	9:45-11:10	TTh	Ghelfi G	SAC B-8	Full Semester
4812014	9:45-11:10	TTh	Guzman K	SAC B-7	Full Semester
(Content of interest to Future Teachers. Open to all students.)					
4812007	6:00-9:10pm	F	Riggins C	SAC D-304	4/18-6/7
AND	9:00-12:10pm	S	Riggins C	SAC D-304	
4812013	Hrs Arr		Heeren J	SAC WEB	Full Semester
(Tckt No 4812013 combines online and on campus instruction. Mandatory on-campus meetings: Tues: Feb 12, Mar 4, Apr 15, May 6, Jun 3, 5-6:30pm, SAC D-305. See Online Courses page in class schedule or go to www.sac.edu/disted for more information.)					
4812081	Hrs Arr		Ghelfi G	SAC TV	Full Semester

HISTORY 121, THE UNITED STATES SINCE 1865 (CAN HIST 10) (CAN HIST SEQ B = HIST 120+121) 3 UNITS					
A critical analysis of America's political, social, cultural, and diplomatic developments since the Civil War.					
4812102	8:00-9:25	MW	Ghelfi G	SAC D-108	Full Semester
4812103	8:00-9:25	TTh	McRoberts M	SAC D-201	Full Semester
4812110	9:00-12:35pm	MTWTh	Ghelfi G	SAC D-205	1/8-1/31
4812108	6:00-9:10pm	F	Menzing T	SAC D-205	4/18-6/7
AND	9:00-12:10pm	S	Menzing T	SAC D-205	
4812106	7:00-10:10pm	M	Ghelfi G	SAC D-205	Full Semester
4812109	7:00-10:10pm	T	Heeren J	SAC B-4	Full Semester
4812114	Hrs Arr		Heeren J	SAC WEB	Full Semester
(Tckt No 4812114 combines online and on campus instruction. Mandatory on-campus meetings: Thurs: Feb 14, Mar 6, Apr 17, May 8, Jun 5, 4-6:50pm, SAC D-102. See Online Courses page in class schedule or go to www.sac.edu/disted for more information.)					
4812181	Hrs Arr		Ghelfi G	SAC TV	Full Semester

HISTORY 121H, HONORS THE UNITED STATES SINCE 1865 3 UNITS					
Seminar-style, content-enriched course for honors students exploring a critical analysis of America's economic, political, cultural, and diplomatic developments since the Civil War. Prerequisite: A high school or college GPA of 3.0 or above.					
4812131	11:30-12:55pm	MW	Osborne T	SAC B-31	Full Semester

TKT#	TIME	DAYS	INSTRUCTOR	LOC./RM.	DATES
HISTORY 124, MEXICAN-AMERICAN HISTORY IN THE UNITED STATES 3 UNITS					
Survey of Mexican-American history in the U.S. from the Pre-Columbian period to the present. Emphasis on Mexican-American contributions to the political, social, economic, and cultural development of the U.S. Will also examine the relationship of Mexican-Americans to other cultural groups.					
4812405	8:00-9:25	MW	Veyna A	SAC D-201	Full Semester
4812402	11:30-12:55pm	MW	Veyna A	SAC D-208	Full Semester
4812404	12:30-1:55pm	TTh	Veyna A	SAC D-213	Full Semester
4812406	1:00-2:25pm	TTh	Guzman K	SAC D-105	Full Semester
4812403	1:15-2:40pm	MW	Veyna A	SAC D-208	Full Semester
4812408	7:00-10:10pm	M	Veyna A	SAC D-208	Full Semester
4812407	7:00-10:10pm	T	Guzman K	SAC D-106	Full Semester

HISTORY 124H, HONORS MEXICAN-AMERICAN HISTORY IN THE UNITED STATES 3 UNITS					
Enriched and intensive survey of Mexican-American history in the U.S. from the Pre-Columbian period to the present. Utilizing a seminar approach, emphasis on Mexican-American contributions to the political, social, economic, and cultural development of the U.S. Will also examine the relationship of Mexican-Americans to other cultural groups. Prerequisite: A high school or college GPA of 3.0 or above.					
4812431	11:30-12:55pm	MW	Guzman K	SAC D-214	Full Semester

HISTORY 127, WOMEN IN U.S. HISTORY 3 UNITS					
A comparative cultural analysis of women's roles in the American past. Emphasis on individuality, family, occupations, and feminine and anti-feminine politics.					
4812705	9:00-12:35pm	MTWTh	Veyna A	SAC D-206	1/8-1/31
4812704	9:45-11:10	TTh	Veyna A	SAC D-205	Full Semester

HISTORY 128H, HONORS AMERICA AND THE QUEST FOR GLOBAL REFORM 3 UNITS					
America's role in working with other nations to build a future while confronting global perils. Stresses how societal change occurs. Prerequisite: A high school or college GPA of 3.0 or above.					
4812831	7:00-10:10pm	W	Osborne T	SAC D-212	Full Semester

HISTORY 133, HISTORY OF CALIFORNIA 3 UNITS					
Examines the social, political and economic developments that have shaped California history.					
4813301	9:45-11:10	MW	Osborne T	SAC D-205	Full Semester

HISTORY 153, HISTORY OF MEXICO 3 UNITS					
General survey course of Mexican history from pre-Columbian times to the present.					
4815301	8:00-9:25	TTh	Veyna A	SAC D-208	Full Semester

HUMAN DEVELOPMENT

The designation DS1, DS2, or DS3 after a course name denotes a class which fulfills one of the California State licensing 12 unit requirements for teachers of preschool children. DS4 denotes the Infant-Toddler licensing requirement. DS5 denotes the School Age licensing requirement.

HUMAN DEVELOPMENT 102, EXPLORING PARENTING PROCESSES 3 UNITS					
Designed to acquaint parents and caregivers with the theory and practical strategies to promote secure and close emotional relationships with children from birth through adolescence. Topics explored include: brain development, special needs, cultural influences and contemporary lifestyles.					
4910201	7:00-10:10pm	T	Bui B	SAC B-21	Full Semester

HUMAN DEVELOPMENT 107, CHILD GROWTH & DEVELOPMENT (DS1) (CAN FCS 14) 3 UNITS					
Study of developmental stages of children from conception through adolescence and the application to interactions with children. No credit for students who have taken Psychology 157.					
4910701	9:30-10:55	MW	Staff	SAC R-318	Full Semester
4910702	9:30-10:55	TTh	Pugh J	SAC R-128	Full Semester
4910704	6:00-9:10pm	W	Torres B	SAC R-114	Full Semester
(Tckt No 4910704 is designated for English language learners. Open to all students.)					
4910706	7:00-10:10pm	M	Pugh J	SAC W-101	Full Semester
4910710	7:00-10:10pm	W	Dunn C	SAC H-207	Full Semester
4910781	Hrs Arr		Pugh J	SAC TV	Full Semester

HUMAN DEVELOPMENT 108A, OBSERVATION AND ASSESSMENT FOR EARLY LEARNING AND DEVELOPMENT 3 UNITS					
This course introduces students to assessment of children and classroom activities in early childhood settings using anecdotal, rating systems, and structured assessment strategies, including state and national standardized measures and related policies. Prerequisite: Human Development 107.					
4910801	9:00-10:25	TTh	Valdez S	SAC B-33	Full Semester
4910803	6:00-9:10pm	T	Goldenberg S	SAC D-209	Full Semester
(Tckt No 4910803 is designated for English language learners. Open to all students.)					
4910802	7:00-10:10pm	T	Wahl S	SAC H-201	Full Semester

Be a Teacher and Touch the Future!



Santa Ana College's Center for Teacher Education can help you reach your goal of becoming a teacher. The Center for Teacher Education offers the following services and resources:

- Orientations to the Teaching Profession
- Specialized Academic Advisement and Counseling
- Information on Teacher Preparation Programs
- Book Loans for Selected Teacher Education Classes
- CBEST and CSET Test Preparation Resource
- Teaching Fieldwork Opportunities

For more information, stop by SAC's Center for Teacher Education, Room S-132, or call us at (714) 564-6352.

Human Development Students!



Get paid experience toward your certificate or degree working with children in RSCCD Child Development Centers.

CALL (714) 564-6894.

HUMAN DEVELOPMENT 110, CHILD, FAMILY AND COMMUNITY (DS2) 3 UNITS

Dynamics of the child-parent-teacher relationships, patterns of communities and examination of the forces in the community that modify the socialization of the child, newborn through adolescence.

4911005	9:00-12:10pm	F	Dumas P	SAC B-33	Full Semester
4911001	11:00-12:25pm	TTh	Valdez S	SAC B-33	Full Semester
4911002	5:00-8:10pm	M	Moran M	SAC B-7	Full Semester
(Tckt No 4911002 is designated for English language learners. Open to all students.)					
4911004	6:00-9:10pm	M	Staff	SAC R-117	Full Semester

HUMAN DEVELOPMENT 111A, PROGRAMMING FOR YOUNG CHILDREN 3 UNITS

This course examines the teacher's role in creating appropriate early childhood environments. Students will develop a teaching philosophy incorporating developmentally-appropriate practice, and emphasizing child-oriented process, positive guidance techniques, classroom transitions, and family/school relations. Prerequisite: Human Development 107 and 108A or 107 and 107L.

4911101	6:00-9:10pm	W	MacKenney V	SAC H-201	Full Semester
(Tckt No 4911101 is designated for English language learners. Open to all students.)					
4911102	6:00-9:10pm	W	Valdez S	SAC B-33	Full Semester

HUMAN DEVELOPMENT 111B, CREATIVE LEARNING EXPERIENCES FOR YOUNG CHILDREN (DS3) 3 UNITS

Explores techniques for planning developmentally appropriate activities and fostering creativity in all curriculum areas of the preschool setting. Prerequisite: Human Development 111A.

4911151	6:00-9:10pm	Th	Morgan-Bezell G	SAC B-33	Full Semester
4911152	6:00-9:10pm	Th	MacKenney V	SAC H-201	Full Semester
(Tckt No 4911152 is designated for English language learners. Open to all students.)					

HUMAN DEVELOPMENT 112, HEALTH, SAFETY & NUTRITION FOR CHILDREN 3 UNITS

Basic concepts about health, safety, food and nutrition as they relate to the young child.

4911202	Hrs Arr		Valdez S	SAC WEB	Full Semester
(Tckt No 4911202: Students must attend all of the following on-campus meetings: Sat, Feb 9, Mar 29, May 3, May 31, Jun 7, 9:30am-12:30pm, SAC B-33. See Online Courses page in class schedule or go to www.sac.edu/disted for more information.)					
4911201	7:00-10:10pm	M	Valdez S	SAC B-33	Full Semester

HUMAN DEVELOPMENT 113, TUTORING READING IN ELEMENTARY SCHOOLS 1 UNIT

An examination of effective tutoring strategies, focusing on the support for reading skills of elementary age children currently reading below grade level. Students are placed in local K-8 classrooms to gain experience with school-age children.

4911301	3:00-6:15pm	W	Torresluna J	SAC B-28	2/27-3/26
---------	-------------	---	--------------	----------	-----------

HUMAN DEVELOPMENT 114, CAREERS IN TEACHING 1 UNIT

Introductory course for a career in teaching. Topics include an overview of the teaching profession, academic preparation, credentialing, career ladders, and goal setting principles. Students will participate in career assessments, formulate a career objective, and develop an educational plan. (Same as Counseling 114.)

4911402	4:00-6:05pm	Th	Nguyen M	SAC B-13	4/17-6/5
4911401	4:45-6:50pm	Th	Bautista S	SAC A-205	2/14-4/3

HUMAN DEVELOPMENT 116B, PROGRAMMING FOR INFANTS AND TODDLERS (DS4) 3 UNITS

Focuses on implementing quality infant/toddler programs, including curriculum, environment, planning and interactions among staff, children and parents. Cultural sensitivity to the diversity of staff and families within such programs will be addressed throughout the course.

4911601	6:30-9:40pm	T	Richey K	SAC B-33	Full Semester
---------	-------------	---	----------	----------	---------------

HUMAN DEVELOPMENT 120, DEVELOPMENT OF THE SCHOOL AGE CHILD (DS5) 3 UNITS

An examination of the physical, cognitive, personality and social development of children between the ages of five and twelve years. Attention will be paid to the scientific study of middle childhood, developmental trends and issues of diversity.

4912001	7:00-10:10pm	Th	Hardy M	SAC R-117	Full Semester
---------	--------------	----	---------	-----------	---------------

HUMAN DEVELOPMENT 200, COMPUTER LITERACY FOR EARLY CHILDHOOD EDUCATORS 3 UNITS

Basic computer science knowledge and skills for child development teachers. Teachers will gain basic computer skills using child development topics.

4920002	7:00-9:50pm	MTWTh	Staff	SAC T-203-1	1/8-2/5
4920001	7:30-10:40pm	W	Staff	SAC T-203-1	Full Semester

HUMAN DEVELOPMENT 205, EXCEPTIONALITY AND SPECIAL NEEDS IN HUMAN DEVELOPMENT 3 UNITS

Diseases and disorders commonly found in children and young adults which result in exceptionality. Emphasis on identifying and learning ways to meet the child's special needs. (Same as Special Services 205.)

4920501	11:30-1:05pm	MW	Creager C	SAC B-33	Full Semester
4920502	7:00-10:10pm	T	Holmes A	SAC R-307	Full Semester

HUMAN DEVELOPMENT 216, ADMINISTRATION OF EARLY CHILDHOOD PROGRAMS: LEVEL II (DS6) 3 UNITS

An examination of the complex role of the administrator of early care and education programs in the areas of establishing and maintaining program quality, selecting, hiring and supporting staff, establishing and facilitating parent, advisory and community relations, and operating a fiscally sound program. Suggested preparation: 12 units in Human Development.

4921601	7:00-10:10pm	W	Mathenia B	SAC R-117	Full Semester
---------	--------------	---	------------	-----------	---------------

HUMAN DEVELOPMENT 220, THE CHILD AS VICTIM 3 UNITS

Exploration of battered, molested and neglected children from five vantage points: child, law, parents, social services and educator.

4922001	9:30-10:55	MW	Pugh J	SAC B-33	Full Semester
4922003	7:00-10:10pm	Th	Pugh J	SAC R-114	Full Semester

HUMAN DEVELOPMENT 221, CROSS CULTURAL PERSPECTIVES IN EARLY CHILDHOOD EDUCATION 3 UNITS

Focuses on developing an understanding, acceptance and appreciation of similarities and differences encountered in our schools and society. Especially relevant for those working with children and families.

4922101	11:00-2:10pm	MW	Morgan-Bezell G	SAC B-29	2/11-4/2
4922103	7:00-10:10pm	W	Robinson K	SAC R-318	Full Semester

HUMAN DEVELOPMENT 250, ADULT SUPERVISION/MENTOR TEACHER IN EARLY CHILDHOOD PROGRAMS 2 UNITS

For the experienced teacher, a study of the methods and principles of supervising adults in early childhood classrooms. Emphasis is on the role of experienced classroom teachers who function as supervisors/mentors to new teachers and staff while simultaneously addressing program quality and the needs of children, parents, and other staff.

4925001	6:00-8:50pm	M	Morgan-Bezell G	SAC B-4	2/11-5/5
---------	-------------	---	-----------------	---------	----------

HUMAN DEVELOPMENT 260, MENTORING ADOLESCENTS I 1.5 UNITS

A study of the role, responsibilities and methods of mentoring. Emphasis on the specific characteristics, challenges and need for mentoring the adolescent in the foster care system. Includes specific information on community resources and health-related topics appropriate to adolescents. Designed for participants of the AmeriCorps program. May be repeated. Grade: CR/NCR only.

4926001	10:00-11:15	F	Aguayo A	SAC R-115	Full Semester
---------	-------------	---	----------	-----------	---------------

HUMAN DEVELOPMENT 298A, SUPERVISED FIELD EXPERIENCE IN EARLY CHILDHOOD PROGRAMS 3 UNITS

Practicum at the Campus Child Development Centers, or approved mentor teacher sites. Prerequisite: Human Development 111B.

4929803	6:00-9:10pm	T	Morgan-Bezell G	CDC 101	Full Semester
---------	-------------	---	-----------------	---------	---------------

Online Counseling Now Available!

www.sac.edu/online_counseling

TKT#	TIME	DAYS	INSTRUCTOR	LOC./RM.	DATES
------	------	------	------------	----------	-------

Teachers needed for children of ALL ages! HUMAN DEVELOPMENT AA AND CERTIFICATE REQUIREMENTS

Want to work with Infants and Toddlers?

AA & CERTIFICATE: Human Dev. Infant/Toddler Option UNITS

HD 107	Child Growth & Development	3
HD 110	Child, Family & Community	3
HD 112	Health, Safety & Nutrition for Children	3
HD 116A	Infant/Toddler Growth & Development	3
HD 116B	Programming for Infants/Toddlers	3
HD 200	Computer Literacy for Early Childhood Education	3
HD 205	Exceptionality & Special Needs in HD	3
HD 220	The Child as Victim	3
HD 221	Cross Cultural Perspectives in Early Childhood Education	3
HD 298B	Infant/Toddler Practicum	3

Total Units 30

HD 117 (Infant & Toddler Care) is no longer offered. Students who previously completed 117 can choose to take either 116A or B to complete the requirements.

Want to work with Preschool Children?

AA & CERTIFICATE: Human Dev. Preschool Option UNITS

HD 107	Child Growth & Development	3
HD 108A	Observation & Assessment for Early Learning & Development	3
HD 110	Child, Family & Community	3
HD 111A	Programming for Young Children	3
HD 111B	Creative Learning Experiences for Young Children	3
HD 112	Health, Safety & Nutrition for Children	3
HD 200	Computer Literacy for Early Childhood Education	3
HD 205	Exceptionality & Special Needs in HD	3
HD 220	The Child as Victim	3
HD 221	Cross Cultural Perspectives in Early Childhood Education	3
HD 298A	Preschool Practicum	3

Total Units 33

Want to work with School-Age Children?

AA & CERTIFICATE: Human Dev. School-Age Option UNITS

Educ 100	Introduction to Education	3
HD 107	Child Growth & Development	3
HD 110	Child, Family & Community	3
HD 113	Tutoring Reading in Elementary Schools	1
HD 114	Careers in Teaching	1
HD 120	Development of School Age Child	3
HD 121	School Age Child Care Activities	3
HD 200	Computer Literacy for Early Childhood Education	3
HD 205	Exceptionality & Special Needs in HD	3
HD 220	The Child as Victim	3
HD 221	Cross Cultural Perspectives in Early Childhood Education	3
HD 299	Cooperative Work Experience Education	1-4

Total Units 30-33

HD 118 (School Age Child Care) is no longer offered. Students who previously completed 118 can choose to take either 120 or 121 to complete the requirements.

HUMAN DEVELOPMENT 298B, INFANT/TODDLER PRACTICUM 3 UNITS

Practicum at the Rancho Santiago Community College District Child Development Centers or approved mentor teacher sites. Prerequisite: Human Development 107, 107L, 111 and 117 or 116A and 116B.

4929804 6:00-9:10pm T Morgan-Beazell G CDC 101 Full Semester

HUMAN DEVELOPMENT 299, COOPERATIVE WORK EXPERIENCE EDUCATION 1-4 UNITS

Supervised paid or volunteer experience in student's major including new or expanded responsibilities. One unit/5 hours experience per week to a maximum of 4 units for 20 hours. Minimum concurrent enrollment in 7 units, including 2 units in Human Development. Self-employed not eligible. Prerequisite: 2 units of Human Development courses.

4929901 5:00-7:05pm Th Dunn C SAC B-7 3/6-5/1

TKT#	TIME	DAYS	INSTRUCTOR	LOC./RM.	DATES
------	------	------	------------	----------	-------

INTERDISCIPLINARY STUDIES

INTERDISCIPLINARY STUDIES 111, INTRODUCTORY LOGIC 4 UNITS

Formal and applied logic. Covers cognitive language, argument and proof, propositional and predicate logic and philosophy of logic. Computer assisted instruction. (Same as Philosophy 111.)

5211102 10:15-12:20pm TTh Fish Z SAC A-206 Full Semester

INTERDISCIPLINARY STUDIES 117H, HONORS INTRODUCTION TO GLOBAL STUDIES 3 UNITS

A multidisciplinary student-driven social science course dealing with a conceptual approach to the cultural, political and economic implications of globalization. Study groups and individual computer-based research focus on the geographic, historical and contemporary settings of globalization. Prerequisite: A high school or college GPA of 3.0 or above.

5211701 1:00-4:10pm M Wood S SAC D-401 Full Semester

INTERDISCIPLINARY STUDIES 117H

Interdisciplinary Studies 117H classes are available in Freshman Experience and Learning Communities II. Enrollment in all classes within a block is required. See additional information on page 26.

U-LINK

INTERDISCIPLINARY STUDIES 117H

5211701 1:00-4:10 M Wood S SAC D-401 Full Semester

ENGLISH 103H

3310375 8:00-10:05 TTh Patterson K SAC B-5 Full Semester

COUNSELING 128

2012803 12:45-3:55pm W Zook R SAC A-207 Full Semester

INTERDISCIPLINARY STUDIES 121, HUMANITIES THROUGH THE ARTS 3 UNITS

An introduction to the humanities through a study of seven major art forms: film, drama, music, literature, painting, sculpture and architecture.

5212181 Hrs Arr Kehlenbach E SAC TV Full Semester

INTERDISCIPLINARY STUDIES 155, HUMAN SEXUALITY 3 UNITS

Examines biological and psychosocial aspects of human sexuality by focusing on love, sexual behavior, gender identity, anatomy and physiology and function, reproduction, sexual arousal/response and sexual dysfunction.

5215502 11:00-12:25pm TTh Goldmann D SAC R-124 Full Semester

OR 11:00-12:25pm TTh Sweeny Y SAC R-124

5215505 11:30-2:50pm MTWTh Sweeny Y SAC R-128 1/7-1/31

5215504 7:00-10:10pm W Sweeny Y SAC R-124 Full Semester

OR 7:00-10:10pm W Goldmann D SAC R-124

JAPANESE

JAPANESE CLASSES REQUIRE LAB TIME

JAPANESE 101, ELEMENTARY JAPANESE I (CAN JAPN SEQ A = JAPN 101+102) 5 UNITS

Pronunciation and speaking, grammar and common idioms, reading and writing. Introduction to culture. Laboratory assignments. Japanese 101 is equivalent to two years of high school Japanese.

5510101 1:45-4:15pm TTh Wadhwa Y SAC D-205 Full Semester

JAPANESE 102, ELEMENTARY JAPANESE II (CAN JAPN 2)

(CAN JAPN SEQ A = JAPN 101+102) 5 UNITS

More complex pronunciation, grammar, vocabulary and cultural study; reading, conversation and composition for the expression of ideas. Laboratory assignments. Japanese 102 is equivalent to the third year of high school Japanese. Prerequisite: Japanese 101 or equivalent, or two years of high school Japanese with a passing grade.

5510202 1:45am-4:15pm TTh Ito M SAC H-201 Full Semester

JOURNALISM

SEE ALSO

TELEVISION/VIDEO COMMUNICATIONS

JOURNALISM 121, NEWS WRITING & REPORTING (CAN JOUR 2) 3 UNITS

Introduction to writing, reporting and gathering news under newsroom conditions. Includes role of the reporter, legal and ethical issues, interviewing skills and Internet reporting. Keyboard skills recommended. Meets CAN JOUR 2 requirements.

5612101 11:00-12:25pm MW Little C SAC A-219 Full Semester

JOURNALISM 122, PUBLICATIONS EDITING 3 UNITS

Introduction to the basic skills of copy editing, headlining, graphic arts, layout, design, printing techniques for publications and advertisements. Emphasizes computerized editing and pagination.

5612201 11:00-12:25pm MW Little C SAC A-219 Full Semester

TKT#	TIME	DAYS	INSTRUCTOR	LOC./RM.	DATES
------	------	------	------------	----------	-------

JOURNALISM 123, NEWSPAPER PRODUCTION**4 UNITS**

Reporting and editing utilizing advanced computerized graphics and layout programs. Using computerized pagination, students produce the campus paper, the el Don. Completion of Journalism 121 recommended. May be repeated.

5612301	12:45-2:50pm	MW	Little C	SAC C-207	Full Semester
AND	10 Hrs Arr		Little C	SAC C-207	

JOURNALISM 124, MAGAZINE WRITING AND PRODUCTION WORKSHOP**3 UNITS**

A comprehensive course in magazine writing and production. Emphasizes a variety of conceptual, research, organizational and writing techniques. Examines trends in editing, layout and design. Students write, edit, design and produce campus magazine. English 101 or Journalism 121 recommended. May be repeated.

5612401	6:00-8:55pm	T	Little C	SAC C-202	Full Semester
AND	5 Hrs Arr		Little C	SAC C-201	

JOURNALISM 130, PRINCIPLES OF BROADCAST NEWS**3 UNITS**

Introduction to broadcast journalism emphasizing the preparation of media newscasts. (Same as Television/Video Communications 130.) Prior or concurrent enrollment in Television/Video Communications 110 recommended.

5613001	11:00-1:30pm	TTh	Bales T	DMC-135	Full Semester
---------	--------------	-----	---------	---------	---------------

JOURNALISM 201, PHOTOJOURNALISM**2 UNITS**

Print related photographic techniques linked to framing, composition and design. Includes application and manipulation of images in digital form. For students interested in action photography, journalism, public relations, design and advertising. Students serve as staff photographers for campus publications. Prerequisite: Photography 180.

5620101	12:45-1:10pm	MW	Little C	SAC C-201	Full Semester
---------	--------------	----	----------	-----------	---------------

JOURNALISM 222, ADVANCED PUBLICATIONS WRITING**3 UNITS**

For experienced journalism/writing students seeking a better understanding of non-fictional prose. Emphasizes publishing, individual writing style, and research methods. Explores career opportunities in media. Prerequisite: Journalism 121.

5622201	12:45-1:10pm	MW	Little C	SAC C-201	Full Semester
---------	--------------	----	----------	-----------	---------------

JOURNALISM 230A, BROADCAST NEWS PRODUCTION**4 UNITS**

Writing, editing, and production of a live weekly newscast. (Same as Television/Video Communications 230A.) Prior or concurrent enrollment in Television/Video Communications 110 recommended. Prerequisite: Journalism 130.

5623001	11:00-1:30pm	TTh	Bales T	DMC-135	Full Semester
AND	4 Hrs Arr		Bales T	DMC-135	

JOURNALISM 230B, BROADCAST NEWS PRODUCTION**4 UNITS**

Writing, editing, and production of a live weekly newscast. (Same as Television/Video Communications 230B.) Prerequisite: Journalism 230A.

5623021	11:00-1:30pm	TTh	Bales T	DMC-135	Full Semester
AND	4 Hrs Arr		Bales T	DMC-135	

JOURNALISM 230C, BROADCAST NEWS PRODUCTION**4 UNITS**

Writing, editing, and production of a live weekly newscast. (Same as Television/Video Communications 230C.) Prerequisite: Journalism 230B.

5623041	11:00-1:30pm	TTh	Bales T	DMC-135	Full Semester
AND	4 Hrs Arr		Bales T	DMC-135	

JOURNALISM 230D, BROADCAST NEWS PRODUCTION**4 UNITS**

Writing, editing, and production of a live weekly newscast. (Same as Television/Video Communications 230D.) Prerequisite: Journalism 230C.

5623061	11:00-1:30pm	TTh	Bales T	DMC-135	Full Semester
AND	4 Hrs Arr		Bales T	DMC-135	

MAGAZINE WRITING & PRODUCTION WORKSHOP

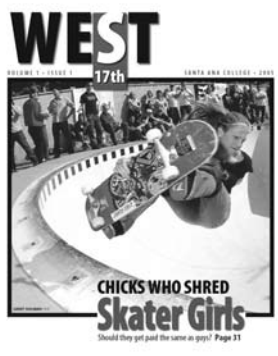
**JOURNALISM 124**

- Learn pre-press fundamentals
- Improve your writing style
- Learn editing and design
- Get your work in print

**Rated America's Best
2-Year College Magazine**

**For More Info
Call 564-5616**

TKT#	TIME	DAYS	INSTRUCTOR	LOC./RM.	DATES
------	------	------	------------	----------	-------



Library Research

Stop wasting time!

Become an efficient user of information resources.
Sign up for 1 unit courses:

LIS 100, Library Research Fundamentals
LIS 103, Information Retrieval on the Internet

**LEGAL ASSISTANT
(SEE PARALEGAL)**

LIBRARY AND INFORMATION STUDIES

LIBRARY AND INFORMATION STUDIES 100, LIBRARY RESEARCH FUNDAMENTALS 1 UNIT

Designed to provide students with survival skills in libraries. Print and non-print information sources such as reference books, magazines, databases and the Internet will be discussed. Students will participate in hands-on exercises in the Library.

5840001	1:00-2:05pm	T	Pedroza L	SAC L-112-1	Full Semester
5840002	1:00-2:05pm	W	Pedroza L	SAC L-112-1	Full Semester

LIBRARY AND INFORMATION STUDIES 103, INFORMATION RETRIEVAL**1 UNIT**

Course will focus on library research strategies for effectively locating and evaluating information on the Internet. Core topics are formulating search strategies, understanding how to form search expressions, evaluating information and citing resources.

5840301	Hrs Arr		Wood S	SAC WEB	4/14-5/31
---------	---------	--	--------	---------	-----------

(See Online Courses page in class schedule or go to www.sac.edu/disted for more information. Email instructor first week of class.)

LIBRARY TECHNOLOGY

LIBRARY TECHNOLOGY 053, LIBRARY INTERNSHIP**3 UNITS**

Closely supervised field work experiences in two carefully selected library settings that will allow the student to apply learned knowledge and skills. To be taken in the last semester of an AA Degree or Certificate in Library Technology. Grade: CR/NCR only. Prerequisite: Library Technology 101, 110, 122.

5805301	Hrs Arr		Garcia Y	SAC L-112-1	Full Semester
---------	---------	--	----------	-------------	---------------

(First class meeting for Library Technology 053, Library Internship, will be the first Wed of the semester, Feb 13, 4-4:55pm, SAC L-112-1)

LIBRARY TECHNOLOGY 101, INTRODUCTION TO LIBRARY TECHNOLOGY**3 UNITS**

Introduction to libraries as a career field with particular emphasis on the role of the library technician in various types of library settings. This course provides an overview of library history, organization, staffing, services, collections, online information sources and terminology.

5810101	6:00-9:10pm	T	Staff	SAC L-112-1	Full Semester
---------	-------------	---	-------	-------------	---------------

LIBRARY TECHNOLOGY 102, INFORMATION SOURCES FOR PARAPROFESSIONALS: TOOLS AND TECHNIQUES**3 UNITS**

An introduction to information sources in both print and electronic formats. Includes a basic theoretical and practical exploration of the nature and types of information in selected subject fields. Builds skills in information searching and in the evaluation of information sources.

5810201	6:00-9:10pm	Th	Gerth K	SAC L-112-1	Full Semester
---------	-------------	----	---------	-------------	---------------

MANAGEMENT

MANAGEMENT 120, PRINCIPLES OF MANAGEMENT**3 UNITS**

Principles, methods, and procedures essential to the successful management of human and financial resources. Planning, organizing, directing, controlling. (Same as Business 120.)

6012005	11:30-12:55pm	TTh	Howe J	SAC A-207	Full Semester
6012007	7:00-10:10pm	W	Howe J	SAC A-130	Full Semester

MANAGEMENT 121, HUMAN RELATIONS & ORGANIZATIONAL BEHAVIOR**3 UNITS**

The role of the manager and management's relationship to employees. Includes the application of motivational theories, communications, leadership, and organizational structure. (Same as Business 121.)

6012102	7:00-10:10pm	T	Iron M	SAC D-103	Full Semester
---------	--------------	---	--------	-----------	---------------

TKT#	TIME	DAYS	INSTRUCTOR	LOC./RM.	DATES
------	------	------	------------	----------	-------

MANAGEMENT 122, BUSINESS COMMUNICATIONS

3 UNITS

Overview of communication skills used in business; emphasizes guidelines for writing and speaking skills necessary for today's high tech, international business environment. Suggested preparation: English 061 or English for Multilingual Students 112 or American College English 116.

6012203	8:00-9:25	MW	Lamarra K	SAC A-203	Full Semester
W 6012202	9:00-12:10pm	S	Hobbs R	SAC A-215	Full Semester
6012207	9:45-11:10	TTh	Doolittle Jr G	SAC A-205	Full Semester
6012205	1:15-2:40pm	TTh	Woolgar D	SAC A-207	Full Semester
6012204	7:00-10:10pm	T	Harasin L	SAC A-130	Full Semester
6012209	7:00-10:10pm	Th	Woolgar D	SAC D-103	Full Semester

MANAGEMENT 135, HUMAN RESOURCE MANAGEMENT

3 UNITS

Introduction to the role, activities, and challenges of human resources. Includes planning and analysis, equal employment and diversity, staffing, development, leadership, motivation, compensation, performance appraisal, and labor/management relations.

6013502	7:00-10:10pm	M	Irion M	SAC D-209	Full Semester
---------	--------------	---	---------	-----------	---------------

MANUFACTURING TECHNOLOGY

MANUFACTURING TECHNOLOGY 011, BASIC BLUEPRINT READING

2 UNITS

Reading and interpreting blueprints for manufacturing. (Same as Engineering 011.)

6251101	8:45-10:50	F	Farmer B	SAC A-130	Full Semester
W 6251102	4:45-6:50pm	F	Bartlett R	SAC R-114	Full Semester

MANUFACTURING TECHNOLOGY 053, TECHNICAL MATHEMATICS

3 UNITS

Essentials of math as they apply to mechanical and machining operations. (Same as Mathematics 053).

6255302	11:00-2:10pm	F	Farmer B	SAC A-130	Full Semester
W 6255301	7:00-10:10pm	F	Bartlett R	SAC R-114	Full Semester

MANUFACTURING TECHNOLOGY 058, BASIC MACHINING CONCEPTS & OPERATIONS

3 UNITS

Fundamental operations on lathes, milling machines, grinders and drill presses, including precision measurement and layout. Concurrent enrollment in Manufacturing Technology 011 is recommended.

6255801	9:00-1:15pm	TTh	Kanzler D	SAC T-107	Full Semester
6255802	5:30-9:45pm	TTh	Gershman B	SAC T-107	Full Semester
6255803	6:00-10:15pm	MW	Kanzler D	SAC T-107	Full Semester

MANUFACTURING TECHNOLOGY 059, ADVANCED TURNING CONCEPTS AND OPERATIONS

3 UNITS

Machine turning theory and skill development with emphasis on lathe construction, tool grinding, and turning machining operations. Prerequisite: Manufacturing Technology 058 with a grade of C or better.

6255901	8:30-12:45pm	TTh	Kanzler D	SAC T-107	Full Semester
6255902	5:30-9:45pm	MW	Kanzler D	SAC T-107	Full Semester

MANUFACTURING TECHNOLOGY 068, ADVANCED MILLING CONCEPTS AND OPERATIONS

3 UNITS

Machine tool theory and skills with emphasis on milling principles, machine capabilities, accessories and operations. Prerequisite: Manufacturing Technology 058 with a grade of C or better.

6256801	8:30-12:45pm	TTh	Kanzler D	SAC T-107	Full Semester
6256802	5:30-9:45pm	MW	Kanzler D	SAC T-107	Full Semester

MANUFACTURING TECHNOLOGY 069, JOB SHOP SKILLS

0.5-3 UNITS

Advanced course with emphasis on planning, setup and machining of a wide variety of projects using all machine tools. Required 48 arranged hours per unit of credit. May be repeated. Prerequisite: Manufacturing Technology 059 and 068.

6256901	8:30-1:15pm	TTh	Kanzler D	SAC T-107	Full Semester
6256902	5:30-9:45pm	MW	Kanzler D	SAC T-107	Full Semester

MANUFACTURING TECHNOLOGY 071, CNC PROGRAM WRITING

3 UNITS

Introductory course for manual CNC program writing. This course will include coordinate system, absolute/incremental programming, circular interpolation, cutter radius compensation, canned cycles, and program formatting. May be repeated. Prerequisite: Prior or concurrent enrollment in Manufacturing Technology 058.

W 6257101	9:00-1:15pm	S	Singh N	SAC T-101	Full Semester
-----------	-------------	---	---------	-----------	---------------

MANUFACTURING TECHNOLOGY 073, MASTERCAM - 2D GEOMETRY, 2D TOOLPATHS

3 UNITS

Creation of 2-D part geometry using lines, arcs, points, and splines. Transformation of the geometry using translate, rotate, mirror, offset. 2-D part programming (toolpaths) including contouring, pocketing, drilling, and tapping. Suggested preparation: Manufacturing Technology 071. May be repeated.

6257301	6:00-7:25pm	TTh	Singh N	SAC T-203-1	Full Semester
AND	2 Hrs Arr		Singh N	SAC T-203-1	

MANUFACTURING TECHNOLOGY 074, CNC MILLING CENTER SET UP AND OPERATION

3 UNITS

Setup and operation of numerically controlled 3 axis milling machine. Emphasis on application of machining controls and CNC machining methods. May be repeated. Prerequisite: Manufacturing Technology 058 and 071 with a grade of C or better.

6257401	7:30-10:40pm	W	Singh N	SAC T-101	Full Semester
AND	2 Hrs Arr		Singh N	SAC T-107	

TKT#	TIME	DAYS	INSTRUCTOR	LOC./RM.	DATES
------	------	------	------------	----------	-------



MANUFACTURING TECHNOLOGY

The Manufacturing Technology Program at Santa Ana College has one of the best equipped machine tool labs in Southern California.

RECOMMENDED FIRST SEMESTER CLASSES

Manufacturing Tech 011	Blueprint Reading
Manufacturing Tech 053	Technical Mathematics
Manufacturing Tech 058	Beginning Machine Operation
Manufacturing Tech 071	CNC Program Writing

NEW MANUFACTURING CLASSES

Manufacturing Tech 086	CNC Lathe With Live Tooling
Manufacturing Tech 094	CNC Horizontal Machining Center

MANUFACTURING TECHNOLOGY 075, MASTERCAM - 3D GEOMETRY, 3D TOOLPATHS

3 UNITS

Continued instruction of computer assisted numerical control programming. Advanced concepts and methods of creating 3-D geometry and 3-D toolpaths using Mastercam 3-D software. Suggested preparation: Manufacturing Technology 073. May be repeated.

6257501	6:00-7:25pm	MW	Singh N	SAC T-203-1	Full Semester
AND	2 Hrs Arr		Singh N	SAC T-203-1	

MANUFACTURING TECHNOLOGY 076, CNC TURNING CENTER SET UP & OPERATION

3 UNITS

Setup and operation of CNC controlled lathes with emphasis on the application of Fanuc 10T machine control and CNC machining methods. Prerequisite: Manufacturing Technology 058 and 071 with a grade of C or better.

6257601	7:30-10:40pm	M	Singh N	SAC T-101	Full Semester
AND	2 Hrs Arr		Singh N	SAC T-107	

MANUFACTURING TECHNOLOGY 077, CAM APPLICATIONS

3 UNITS

Advanced concepts in the manufacturing of machine parts using CAM software and CNC machining centers. Emphasis placed on programming and machining 3 dimensional surfaces. Problem solving in roughing, finishing, fixturing, and machining of a variety of part configurations. Suggested preparation: Manufacturing Technology 073 and 075 or 081 and 082. May be repeated.

6257701	7:30-10:40pm	Th	Singh N	SAC T-101	Full Semester
AND	Hrs Arr		Singh N	SAC T-107	

MANUFACTURING TECHNOLOGY 084, ADVANCED CNC MILL SET UP

3 UNITS

Advanced set up and operation of CNC machining center mill. Course curriculum will include instruction on boring cycles, reaming cycle, thread milling, 4th AXIS rotary table and multiple fixture offsets. May be repeated. Prerequisite: Manufacturing Technology 071 and 074.

6258401	7:30-10:40pm	T	Singh N	SAC T-101	Full Semester
AND	2 Hrs Arr		Singh N	SAC T-101	

MANUFACTURING TECHNOLOGY N96, MACHINE TOOL LABORATORY

0 UNITS

Supervised use of the machine tool lab for experience in set-up and operation of both conventional and CNC machine tools. Not applicable to associate degree. Open entry/open exit. May be repeated. Prerequisite: Concurrent enrollment in Manufacturing Technology courses requiring machine tool laboratory hours.

W 6259607	9:00-1:15pm	S	Singh N	SAC T-101	Full Semester
6259601	9:00-1:15pm	TTh	Kanzler D	SAC T-107	Full Semester
6259605	2:30-5:30pm	MTWTh	Bayard J	SAC T-107	Full Semester
6259609	5:30-7:30pm	TTh	Gershman B	SAC T-107	Full Semester
6259604	5:30-8:25pm	MW	Kanzler D	SAC T-107	Full Semester
6259608	7:30-10:40pm	Th	Singh N	SAC T-107	Full Semester
6259606	7:30-10:40pm	Th	Singh N	SAC T-107	Full Semester
6259602	8:30-10:40pm	M	Singh N	SAC T-107	Full Semester
6259603	8:30-10:40pm	W	Singh N	SAC T-107	Full Semester

MANUFACTURING TECHNOLOGY N97, CAD/CAM COMPUTER LABORATORY

0 UNITS

Supervised use of CAD/CAM computer Lab for experience in the use of personal computers and software being used in CAD/CAM classes. Not applicable to associate degree. Open entry/open exit. May be repeated. Prerequisite: Concurrent enrollment in Manufacturing Technology courses requiring CAD/CAM Computer laboratory hours.

6259701	2:30-5:30pm	MTWTh	Bayard J	SAC T-107	Full Semester
6259702	6:00-9:10pm	Th	Cole J	SAC T-203	Full Semester

MANUFACTURING TECHNOLOGY 103, SOLIDWORKS BASIC SOLID MODELING

3 UNITS

Creation of solid models and 3D toolpaths using Solidworks software. (Same as Engineering 103.) May be repeated.

6260302	6:00-10:10pm	M	Corley G	SAC T-203	Full Semester
AND	1 Hr Arr		Corley G	SAC T-203	
6260301	6:00-10:10pm	T	Corley G	SAC T-203	Full Semester
AND	1 Hr Arr		Corley G	SAC T-203	

TKT#	TIME	DAYS	INSTRUCTOR	LOC./RM.	DATES
MANUFACTURING TECHNOLOGY 104, SOLIDWORKS INTERMEDIATE					
SOLID MODELING 3 UNITS					
Creation of solid models and 2D detail drawings using Solidworks software. (Same as Engineering 104.) May be repeated. Prerequisite: Manufacturing Technology 083 or 103.					
6260401	6:00-9:10pm	W	Cole J	SAC T-203	Full Semester
AND	2 Hrs Arr		Cole J	SAC T-203	
MANUFACTURING TECHNOLOGY 105, SOLIDWORKS ADVANCED					
SOLID MODELING 3 UNITS					
Advanced solid modeling procedures; use of Photoworks and Animator. (Same as Engineering 105.) May be repeated. Prerequisite: Manufacturing Technology 104.					
6260501	6:00-9:10pm	Th	Cole J	SAC T-203	Full Semester
AND	2 Hrs Arr		Cole J	SAC T-203	
MANUFACTURING TECHNOLOGY 114, GEOMETRIC DIMENSIONING AND TOLERANCING 3 UNITS					
Drawing interpretation utilizing geometric dimensioning and tolerancing (ANSI Y14.5) as applied in engineering, manufacturing, and inspection. Suggested preparation: Prior or concurrent enrollment in Manufacturing Technology 011 or Engineering 122. (Same as Engineering 114.)					
6261402	7:00-10:10pm	M	Bartlett R	SAC R-114	Full Semester
MANUFACTURING TECHNOLOGY 188, MACHINE TECHNOLOGY SURVEY 3 UNITS					
Fundamentals of machine tool setup and operation including general knowledge of machine tools and processes. For non-Manufacturing Technology majors. Students must furnish safety eye wear and 6 inch rule. (Same as Engineering 188.) Prerequisite: Successful completion of or concurrent enrollment in Manufacturing Technology 011; Engineering 011, 051; or Automotive Technology 002 or 006.					
6268801	9:00-1:15pm	TTh	Kanzler D	SAC T-107	Full Semester
6268802	5:30-9:45pm	TTh	Gershman B	SAC T-107	Full Semester

**MARINE STUDIES
(SEE GEOLOGY)**

MARKETING

MARKETING 113, PRINCIPLES OF MARKETING 3 UNITS					
The process of developing products that will satisfy the many needs of consumers and businesses. Includes market research techniques, pricing, distribution, and promotion.					
6211301	9:45-11:10	TTh	Howe J	SAC A-207	Full Semester
6211303	7:00-10:10pm	W	Grant M	SAC A-207	Full Semester
MARKETING 114, PROFESSIONAL SELLING 3 UNITS					
Introductory course in sales covering sales presentations, communication styles, prospecting, closing, and evaluation of selling techniques and practices. Includes individual and business objectives in selling from the perspective of the consumer, business and society.					
6211401	7:00-10:10pm	Th	Russo Jr J	SAC A-207	Full Semester
MARKETING 115, CONSUMER BEHAVIOR 3 UNITS					
The investigation and analysis of why consumers select, purchase, use, and dispose of goods and services to satisfy their personal and household needs.					
6211502	7:00-10:10pm	M	Grooms M	SAC D-103	Full Semester

Mathematics Course Icons

CAI

Students will be required to use the MyMathLab or other software which is packaged with new textbooks. Homework and/or quizzes will be submitted via the internet. May not be Mac compatible.



Graphing Calculators will be required.
TI-84+ Recommended

MATHEMATICS

The content of Math N05 and Math N06 is the same, but the methods of instruction differ. Math N05 is self-paced and students may take more than one semester to earn the full 3 units. Math N06 students experience a more structured environment and must complete the course in one semester. Former Math N05 students, who have earned 1 or more units should enroll in Math N05 to complete their study of Basic Math.

MATHEMATICS N05, BASIC MATHEMATICS 0.5-3 UNITS					
Reviews whole numbers, fractions, decimals, percents, basic geometry formulas and signed numbers. Not applicable to associate degree. Open entry/open exit. Grade: CR/NCR only.					
6300501	8:00-10:05	MW	Marecek L	SAC L-202	Full Semester
6300509	9:00-1:15pm	F	Fazeli F	SAC L-202	Full Semester
6300502	10:15-12:20pm	TTh	Rogers N	SAC L-202	Full Semester
6300504	12:30-2:35pm	TTh	Cedeno J	SAC L-206	Full Semester
6300503	1:00-3:05pm	MW	MacBride-Hart C	SAC L-202	Full Semester
6300505	5:45-10:00pm	T	Felton, Jr. D	SAC L-202	Full Semester
6300507	5:45-10:00pm	W	Felton, Jr. D	SAC L-206	Full Semester

MATHEMATICS N06, ESSENTIAL MATHEMATICS 3 UNITS					
Reviews whole numbers, fractions, decimals, percents, basic geometry formulas and signed numbers. Not applicable to associate degree. Score of 10-20 on Math Level 1 Placement Test recommended.					
6300601	8:00-10:05	MW	Rogers N	SAC L-207	Full Semester
6300650	9:00-1:35pm	MTWTh	Rollings-Logay E	SAC L-207	1/7-1/31
6300602	9:15-11:20	TTh	Bajaj J	SAC L-207	Full Semester
6300603	10:15-12:20pm	MW	Ternes L	SAC L-207	Full Semester
6300604	11:30-1:35pm	TTh	Bajaj J	SAC L-207	Full Semester
6300612	4:30-6:35pm	TTh	Sheldon J	SAC L-207	Full Semester
6300606	5:30-7:35pm	MW	Rollings-Logay E	SAC L-207	Full Semester
6300607	5:45-10:00pm	Th	Powers R	SAC B-26	Full Semester
6300618	7:45-9:50pm	MW	Rollings-Logay E	SAC L-207	Full Semester

MATHEMATICS 030, COPING WITH MATH ANXIETY 1 UNIT					
How to overcome math anxiety. Review and practice of basic math skills.					
6303002	2:45-4:50pm	T	Marecek L	SAC H-109	3/11-5/6

MATHEMATICS N47, PRE-ALGEBRA/ALGEBRA ESSENTIALS 1-4 UNITS						
Designed for students with little or no algebra background. Not applicable to the associate degree. Open entry/open exit. Grade: CR/NCR only. Prerequisite: Math N05 or Math N06 with a grade of C or better or equivalent skills as measured by the Math Level 1 Exam and a course equivalent to Math N05 or N06.						
CAI	6304701	8:00-10:05	MW	Marecek L	SAC L-202	Full Semester
CAI	6304709	9:00-1:15pm	F	Fazeli F	SAC L-202	Full Semester
CAI	6304702	10:15-12:20pm	TTh	Rogers N	SAC L-202	Full Semester
CAI	6304704	12:30-2:35pm	TTh	Cedeno J	SAC L-206	Full Semester
CAI	6304703	1:00-3:05pm	MW	MacBride-Hart C	SAC L-202	Full Semester
CAI	6304705	5:45-10:00pm	T	Felton, Jr. D	SAC L-202	Full Semester
CAI	6304707	5:45-10:00pm	W	Felton, Jr. D	SAC L-206	Full Semester

MATHEMATICS N48, PRE-ALGEBRA/ALGEBRA BASICS 4 UNITS						
Designed for students with little or no algebra background. Not applicable to associate degree. Prerequisite: Mathematics N05 or N06 with a grade of C or better or equivalent skills as measured by the Math Level 1 Exam and a course equivalent to Mathematics N05 or N06.						
	6304828	7:00am-9:05	MW	Hashemi S	SAC B-11	Full Semester
	6304823	7:00am-9:05	TTh	Hashemi S	SAC L-207	Full Semester
	6304802	8:00-10:05	MW	Ternes L	SAC H-105	Full Semester
W	6304860	8:00-12:15pm	S	Staff	SAC L-207	Full Semester
	6304850	8:00-12:35pm	MTWTh	Marecek L	SAC L-203	1/7-1/31
	6304803	9:00-11:05	TTh	Anthony M	SAC L-203	Full Semester
	6304809	10:15-12:20pm	MW	Marecek L	SAC B-14	Full Semester
	6304806	11:00-1:05pm	MW	Anthony M	SAC L-203	Full Semester
	6304805	11:15-1:20pm	TTh	Marecek L	SAC L-203	Full Semester
	6304811	12:30-2:35pm	TTh	Rogers N	SAC B-14	Full Semester
	6304820	1:15-3:20pm	MW	Porter S	SAC L-203	Full Semester
	6304829	3:00-5:05pm	TTh	Cedeno J	SAC H-105	Full Semester
	6304814	3:30-5:35pm	MW	Kassman S	SAC L-203	Full Semester
	6304851	4:00-8:35pm	MTWTh	Meier K	SAC L-203	1/7-1/31
	6304816	5:45-7:50pm	MW	Elizondo G	SAC L-203	Full Semester
	6304818	5:45-10:00pm	Th	Solheid C	SAC G-106	Full Semester
	6304815	6:00-8:05pm	TTh	Leeds K	SAC L-203	Full Semester
	6304821	7:45-9:50pm	TTh	Pai R	SAC B-14	Full Semester
	6304819	8:00-10:05pm	MW	Elizondo G	SAC L-203	Full Semester

MATHEMATICS 053, TECHNICAL MATHEMATICS 3 UNITS						
Essentials of math as they apply to mechanical and machining operations. (Same as Manufacturing Technology 053). Prerequisite: Mathematics N48 with a grade of C or better, or equivalent skills as measured by the Math Level 1 Exam.						
	6305302	11:00-2:10pm	F	Farmer B	SAC A-130	Full Semester
W	6305301	7:00-10:10pm	F	Bartlett R	SAC R-114	Full Semester

MATHEMATICS 060, ELEMENTARY ALGEBRA 4 UNITS						
The first course in algebra. Prerequisite: Successful completion of Mathematics N48 or equivalent skills as measured by a satisfactory score on the Math Level 1 or 2 Exam in combination with a course equivalent to Mathematics N48 or above.						
	6306036	7:00am-9:05	MW	Minasian A	SAC H-104	Full Semester
	6306019	7:00am-9:05	TTh	Pham T	SAC H-107	Full Semester
	6306026	7:30am-9:35	TTh	Go J	SAC H-104	Full Semester
	6306003	8:00-10:05	MW	Taba K	SAC H-107	Full Semester
	6306004	8:00-10:05	TTh	Airey D	SAC H-109	Full Semester
W	6306060	8:00-12:15pm	S	Pilz L	SAC H-107	Full Semester
	6306050	8:00-12:35pm	MTWTh	Zarske J	SAC H-107	1/7-1/31
	6306005	8:45-10:50	MW	Proffitt J	SAC L-203	Full Semester
	6306052	9:00-1:35pm	MTWTh	McKowan L	SAC B-13	1/7-1/31
	6306030	9:45-11:50	MW	Lechuga J	SAC H-108	Full Semester
	6306020	10:00-12:05pm	TTh	Bourouis-Benyas A	SAC H-105	Full Semester
	6306011	10:15-12:20pm	TTh	Airey D	SAC B-11	Full Semester
	6306042	10:15-12:20pm	TTh	Go J	SAC H-109	Full Semester
	6306035	12:30-2:35pm	TTh	Chan R	SAC B-5	Full Semester
	6306009	12:45-2:50pm	MW	Kassman S	SAC B-11	Full Semester
	6306037	1:00-3:05pm	MW	McKowan L	SAC R-303	Full Semester
	6306001	1:30-3:35pm	TTh	Shirman T	SAC L-203	Full Semester
	6306025	2:45-4:50pm	MW	Meier K	SAC H-105	Full Semester
	6306010	2:45-4:50pm	TTh	Chan R	SAC R-114	Full Semester
	6306044	3:15-5:20pm	TTh	Zeller M	SAC H-108	Full Semester

Mathematics Course Sequences

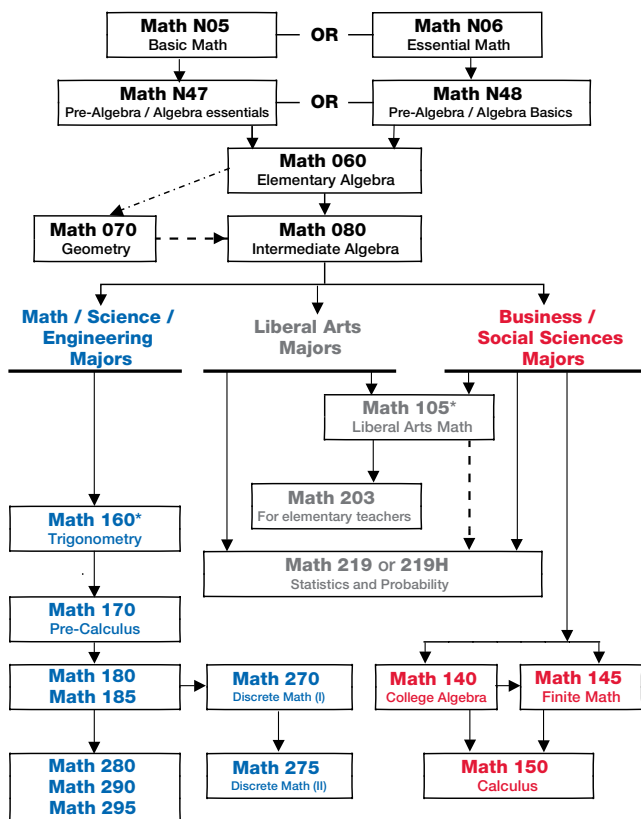

Note: Where a student places in the sequence will depend upon previous background and test scores. Check prerequisites for all courses.

Note: Students planning to transfer to a four-year school should work carefully with a counselor and the catalog of the school of transfer. A college major should be chosen by the end of Math 080 to ensure enrollment in the most appropriate subsequent class.

*Geometry is prerequisite.

6306021	3:45-5:50pm	TTh	Shirman T	SAC L-203	Full Semester
6306051	4:00-8:35pm	MTWTh	Pai R	SAC H-107	1/7-1/31
6306029	5:00-7:05pm	MW	Maiah A	SAC G-106	Full Semester
6306012	5:30-7:35pm	TTh	Zeller M	SAC H-108	Full Semester
CAI 6306013	6:00-8:05pm	MW	Mahoney J	SAC B-14	Full Semester
6306024	7:30-9:35pm	TTh	Litovsky A	SAC L-207	Full Semester
CAI 6306045	8:15-10:20pm	MW	Mahoney J	SAC B-14	Full Semester
6306041	8:15-10:20pm	TTh	Fletcher H	SAC L-203	Full Semester
6306070	Hrs Arr		Everett M	SAC WEB	Full Semester

(Mandatory class meetings Fri, Feb 8, Mar 14, Apr 18, May 16, Jun 6, 6-8pm, SAC H-107. See Online Courses page in class schedule or go to www.sac.edu/disted for more information.)

MATH 060

Math 060 classes are available in Freshman Experience and Learning Communities II. Enrollment in all classes within a block is required. See additional information on page 26.

MATH 060

6306031	10:15-12:20pm	MW	Rogers N	SAC H-105	Full Semester
---------	---------------	----	----------	-----------	---------------

COUNSELING 116

2011671	9:00-12:10pm	F	Guillen D	SAC A-209	Full Semester
---------	--------------	---	-----------	-----------	---------------

MATH 060

6306008	7:45am-9:50	TTh	Marecek L	SAC H-105	Full Semester
---------	-------------	-----	-----------	-----------	---------------

COUNSELING 116

2011675	10:00-11:25	TTh	Robledo R	SAC B-31	Full Semester
---------	-------------	-----	-----------	----------	---------------

MATHEMATICS 070, GEOMETRY

Basic Euclidean Geometry. Prerequisite: Successful completion of Mathematics 060 or equivalent skills as measured by a satisfactory score on the Math Level 2 exam in combination with an Elementary Algebra course.

6307001	12:30-2:35pm	MW	Proffitt J	SAC H-105	Full Semester
---------	--------------	----	------------	-----------	---------------

MATHEMATICS 080, INTERMEDIATE ALGEBRA

Second year of algebra. Provides essentials for courses requiring algebra. Prerequisite: Successful completion of Mathematics 060 or equivalent skills (measured by a satisfactory score on the Math Level 2 exam) in combination with an Elementary Algebra course.

6308041	6:30am-9:00	TTh	Minasian A	SAC R-114	Full Semester
CAI 6308001	7:00am-9:30	MW	Rossetti C	SAC B-13	Full Semester
6308038	7:00am-9:30	MW	Lechuga J	SAC R-318	Full Semester
6308006	7:00am-9:30	TTh	Bourouis-Benyas A	SAC B-14	Full Semester
CAI 6308036	7:00am-9:30	TTh	Rossetti C	SAC H-108	Full Semester
6308013	7:30am-10:00	MW	Mayo W	SAC B-14	Full Semester
6308050	8:00-12:45pm	MTWThF	Everett M	SAC B-14	1/7-2/1
W 6308060	8:00-1:20pm	S	Nguyen K	SAC H-105	Full Semester
6308052	9:00-1:45pm	MTWThF	Leeds K	SAC H-109	1/7-2/1
6308004	9:15-11:45	TTh	Zarske J	SAC R-114	Full Semester
CAI 6308023	9:30-12:00pm	MW	Root A	SAC R-114	Full Semester
CAI 6308007	9:45-12:15pm	TTh	Rossetti C	SAC B-14	Full Semester
6308010	12:00-2:30pm	TTh	Vu Y	SAC R-114	Full Semester
6308002	12:15-2:30pm	TTh	Everett M	SAC H-105	Full Semester
6308035	12:30-3:00pm	MW	Leeds K	SAC B-14	Full Semester
6308028	2:30-5:00pm	TTh	Solheid C	SAC R-128	Full Semester
CAI 6308014	2:45-5:15pm	MW	Root A	SAC L-207	Full Semester
6308029	3:15-5:45pm	MW	Leeds K	SAC B-14	Full Semester
6308051	4:00-8:45pm	MTWThF	Jackson C	SAC H-109	1/7-2/1
6308021	4:30-7:00pm	MW	Vu Y	SAC R-318	Full Semester
6308020	4:30-7:00pm	TTh	Meier K	SAC H-107	Full Semester
6308016	5:00-7:30pm	MW	Shafigh M	SAC H-105	Full Semester
6308030	5:15-7:45pm	TTh	Bowers C	SAC H-105	Full Semester
6308032	7:00-9:30pm	TTh	Nguyen T	SAC B-11	Full Semester
6308017	7:45-10:15pm	MW	Maiah A	SAC H-105	Full Semester
6308070	Hrs Arr		Solheid C	SAC WEB	Full Semester

(Mandatory class meetings Fri, Feb 8, Mar 14, Apr 18, May 16, Jun 6, 6-8pm, SAC L-207. See Online Courses page in class schedule or go to www.sac.edu/disted for more information.)

6308071	Hrs Arr		Solheid C	SAC WEB	Full Semester
---------	---------	--	-----------	---------	---------------

(Mandatory class meetings Sat, Feb 9, Mar 15, Apr 19, May 17, and Jun 7, 9-11:30am, SAC L-203. See Online Courses page in class schedule or go to www.sac.edu/disted for more information.)

MATH 080

Math 080 classes are available in Freshman Experience and Learning Communities II. Enrollment in all classes within a block is required. See additional information on page 26.

MATH 080

6308009	12:15-2:45pm	MW	Vu Y	SAC R-114	Full Semester
---------	--------------	----	------	-----------	---------------

COUNSELING 116

2011677	10:30-11:55	MW	Campos J	SAC J-101	Full Semester
---------	-------------	----	----------	-----------	---------------

The following Math classes meet the general education and/or the Math requirement for transfer: Math 105, Math 140, Math 219. See your counselor for more information.

MATHEMATICS 105, MATHEMATICS FOR LIBERAL ARTS STUDENTS (CAN MATH 2)3 UNITS

Topics will include financial management, probability, statistics and selected topics such as geometry, logic, math modeling, and the history of mathematics. Prerequisite: Mathematics 080 with a grade of C or better or equivalent skills as measured by the Math Level 3 Exam and a course equivalent to Mathematics 080.

6310509	8:00-10:05	TTh	Everett M	SAC B-11	Full Semester
W 6310560	8:00-12:15pm	S	Jackson C	SAC H-207	Full Semester
CAI 6310550	8:30-1:05pm	MTWTh	Khakbazan M	SAC H-104	1/7-1/31
CAI 6310501	10:15-12:20pm	MW	Khakbazan M	SAC H-109	Full Semester
6310502	10:15-12:20pm	TTh	Sci Staff	SAC G-106	Full Semester
6310504	5:00-7:05pm	TTh	Hendon S	SAC H-109	Full Semester
6310570	Hrs Arr		Everett M	SAC WEB	Full Semester

(Mandatory class meetings Fri, Feb 8, Mar 14, May 16, Jun 6, 4-6pm, SAC H-107. See Online Courses page in class schedule or go to www.sac.edu/disted for more information.)

MATH 105

Math 105 classes are available in Freshman Experience and Learning Communities II. Enrollment in all classes within a block is mandatory. For additional information see page 26.

MATH 105

6310508	3:15-5:20pm	MW	Bowers C	SAC H-107	Full Semester
---------	-------------	----	----------	-----------	---------------

COUNSELING 116

2011672	5:30-6:55pm	MW	Blake S	SAC R-115	Full Semester
---------	-------------	----	---------	-----------	---------------

TKT#	TIME	DAYS	INSTRUCTOR	LOC./RM.	DATES
<p>Graphing Calculators will be required in Math 140, 145, 150, 160, 170, 180, 185, 275,280 and 295. TI83 or TI 84 is recommended.</p>					
MATHEMATICS 140, COLLEGE ALGEBRA (CAN MATH 10)					4 UNITS
<p>Survey of advanced topics in algebra including polynomial, rational, exponential and logarithmic functions, series, and probability. Prerequisite: Mathematics 080 with a grade of C or better or equivalent skills as measured by the Math Level 3 Exam and a course equivalent to Mathematics 080.</p>					
6314004	7:15am-9:20	MW	Fazeli F	SAC R-114	Full Semester
6314060	8:00-12:15pm	S	Bui M	SAC H-109	Full Semester
6314050	8:00-12:35pm	MTWTh	Ternes L	SAC H-105	1/7-1/31
6314003	10:15-12:20pm	MW	Morrison J	SAC H-107	Full Semester
6314007	2:15-4:20pm	TTh	Hager B	SAC H-107	Full Semester
6314012	5:30-7:35pm	MW	Lieu T	SAC H-107	Full Semester
6314008	8:00-10:05pm	TTh	Nguyen T	SAC H-105	Full Semester
6314009	8:15-10:20pm	MW	Nguyen D	SAC H-108	Full Semester
6314070	Hrs Arr		Sorcabal C	SAC WEB	Full Semester
<p>(Mandatory class meetings Fri, Feb 8, Mar 14, Apr 18, May 16, Jun 6, 6-8pm, SAC H-105. See Online Courses page in class schedule or go to www.sac.edu/disted for more information.)</p>					

MATH 140
Math 140 classes are available in Freshman Experience and Learning Communities II. Enrollment in all classes within a block is mandatory. For additional information see page 26.

TKT#	TIME	DAYS	INSTRUCTOR	LOC./RM.	DATES
MATH 140					
CA1 6314006	9:15-11:20	TTh	Root A	SAC H-107	Full Semester
COUNSELING 116					
2011682	11:30-12:55pm	TTh	Turner E	SAC B-13	Full Semester

TKT#	TIME	DAYS	INSTRUCTOR	LOC./RM.	DATES
MATHEMATICS 145, FINITE MATHEMATICS					
<p>Set algebra, introduction to probability and counting, matrix algebra, linear programming and the simplex method, mathematics of finance, introduction to statistics. Prerequisite: Mathematics 080 with a grade of C or better or equivalent skills as measured by the Math Level 3 exam and a course equivalent to Mathematics 080.</p>					
6314501	12:30-2:35pm	MW	Khakbazan M	SAC L-207	Full Semester

TKT#	TIME	DAYS	INSTRUCTOR	LOC./RM.	DATES
MATHEMATICS 150, CALCULUS FOR BIOLOGICAL, MANAGEMENT & SOCIAL SCIENCES (CAN MATH 34)					
<p>A survey of problems from the biological, management and social science fields which may be solved with the aid of calculus. Prerequisite: Successful completion of Mathematics 140 or 145 or equivalent skills as measured by a satisfactory score on the Math Level 3 Exam in combination with a course equivalent to Mathematics 140.</p>					
W 6315060	8:00-1:20pm	S	Pai R	SAC H-104	Full Semester
6315001	9:45-12:15pm	TTh	Sheldon J	SAC H-104	Full Semester
6315005	3:15-5:45pm	MW	McKowan L	SAC H-109	Full Semester
6315008	5:30-8:00pm	MW	Meier K	SAC B-26	Full Semester
6315006	7:15-9:45pm	TTh	Ly L	SAC H-109	Full Semester



Is your major mathematics, engineering, computer science, biology, chemistry, or related field? If yes, this opportunity is for you! Special learning community courses will be offered this semester in Chemistry 209 and Math 160. Each course will be paired with a counseling class. Take advantage of this learning community experience! Please see the Freshman Experience and Learning Communities information in this schedule, page 14, for more details.
For additional information, please contact the MESA Center at (714) 564-6373.

TKT#	TIME	DAYS	INSTRUCTOR	LOC./RM.	DATES
MATHEMATICS 160, TRIGONOMETRY (CAN MATH 8)					
<p>Trigonometric functions and their application. Trigonometric identities and equations. Complex numbers and polar coordinates. Prerequisite: Mathematics 070 and 080 with a grade of C or better or equivalent skills as measured by the Math Level 3 exam and courses equivalent to Mathematics 070 and 080.</p>					
6316008	8:00-10:05	MW	Morrison J	SAC H-109	Full Semester
6316001	11:00-1:05pm	TTh	MacBride-Hart C	SAC R-318	Full Semester
6316004	12:30-2:35pm	TTh	McClure C	SAC H-109	Full Semester
6316005	6:00-8:05pm	MW	Klaus R	SAC H-109	Full Semester

TKT#	TIME	DAYS	INSTRUCTOR	LOC./RM.	DATES
MATHEMATICS 165, INTRODUCTION TO MATH TUTORING					
<p>1 UNIT Role and responsibility of the math tutor. Includes training in individualized and small group instruction, communication skills, cultural awareness, learning styles, problem solving techniques, new technologies, and an overview of the math curriculum. Student will be required to volunteer in the Math Study Center as part of the arranged hours.</p>					
6316550	1:00-2:50pm	TTh	Everett M	SAC L-203	1/8-1/31
MATHEMATICS 170, PRE-CALCULUS MATHEMATICS (CAN MATH 16)					
<p>4 UNITS Rational, trigonometric, exponential, and logarithmic functions. Preparation for Mathematics 180. Prerequisite: Mathematics 160 with a grade of C or better or equivalent skills as measured by the Math Level 4 Exam and a course equivalent to Mathematics 160.</p>					
6317001	11:30-2:00pm	TTh	Kashi M	SAC H-107	Full Semester
6317004	7:15-9:45pm	TTh	Hager B	SAC H-107	Full Semester
6317007	7:45-10:15pm	MW	Lieu T	SAC H-107	Full Semester

MATH 170
Math 170 classes are available in Freshman Experience and Learning Communities II. Enrollment in all classes within a block is mandatory. For additional information see page 26.

TKT#	TIME	DAYS	INSTRUCTOR	LOC./RM.	DATES
MESA MATH 170					
6317003	12:30-3:00pm	MW	Sill K	SAC H-107	Full Semester
COUNSELING 111					
2011102	9:00-10:50	F	Plum C	SAC H-105	Full Semester

TKT#	TIME	DAYS	INSTRUCTOR	LOC./RM.	DATES
MATHEMATICS 180, ANALYTIC GEOMETRY & CALCULUS (CAN MATH 18) (CAN MATH SEQ B = MATH 180+185) (CAN MATH SEQ C = MATH 180+185+280)					
<p>4 UNITS Limits and continuity derivatives and integrals of algebraic and trigonometric functions. Applications of derivatives and integrals. Prerequisite: Mathematics 170 with a grade of C or better or equivalent skills as measured by the Math Level 4 Exam and a course equivalent to Mathematics 170.</p>					
6318001	9:15-11:45	MW	MacBride-Hart C	SAC H-104	Full Semester
6318004	12:00-2:35pm	MW	Kashi M	SAC H-104	Full Semester
6318002	12:30-3:00pm	TTh	Leeds K	SAC H-104	Full Semester
6318006	6:00-8:30pm	TTh	Sill K	SAC H-104	Full Semester

TKT#	TIME	DAYS	INSTRUCTOR	LOC./RM.	DATES
MATHEMATICS 185, ANALYTIC GEOMETRY AND CALCULUS (CAN MATH 20) (CAN MATH SEQ B = MATH 180+185) (CAN MATH SEQ C = MATH 180+185+280)					
<p>4 UNITS Calculus of transcendental functions, integration techniques, conics, parametric equations, polar coordinates, indeterminate forms, and infinite series. Prerequisite: Mathematics 180 or 180H with a grade of C or better.</p>					
6318505	2:45-5:15pm	MW	Kashi M	SAC H-104	Full Semester
6318501	7:45-10:15pm	MW	Tran F	SAC H-104	Full Semester

TKT#	TIME	DAYS	INSTRUCTOR	LOC./RM.	DATES
MATHEMATICS 203, MATH FOR FUTURE ELEMENTARY TEACHERS (CAN MATH 4)					
<p>4 UNITS Designed for prospective elementary teachers, the course emphasizes problem solving techniques and mathematical structures. This course includes instructional delivery design and activity based explorations. Prerequisite: Mathematics 105 or 140 or 145 or 170 or 219 or 219H or Social Science 219 or 219H with a grade of C or better.</p>					
6320302	12:30-2:35pm	MW	Bowers C	SAC H-109	Full Semester

TKT#	TIME	DAYS	INSTRUCTOR	LOC./RM.	DATES
MATHEMATICS 219, STATISTICS AND PROBABILITY					
<p>4 UNITS Beginning course in statistics. Includes use of computer software. (Same as Social Science 219.) Prerequisite: Mathematics 080 or 140 with a grade of C or better or equivalent skills as measured by the Math Level 3 Exam and a course equivalent to Mathematics 080 or 140.</p>					
6321911	7:00am-9:30	MW	Ortiz F	SAC H-108	Full Semester
W 6321960	8:00-1:20pm	S	Rivera F	SAC H-108	Full Semester
CA1 6321950	8:30-1:15pm	MTWThF	Anthony M	SAC H-108	1/7-2/1
6321901	9:45-12:15pm	TTh	McClure C	SAC H-108	Full Semester
6321902	12:00-2:30pm	MW	Zarske J	SAC H-108	Full Semester
CA1 6321908	12:30-3:00pm	TTh	Anthony M	SAC H-108	Full Semester
6321914	2:45-5:15pm	MW	Klaus R	SAC H-108	Full Semester
6321903	5:30-8:00pm	MW	Pham T	SAC H-108	Full Semester
6321904	7:45-10:15pm	TTh	Nguyen D	SAC H-108	Full Semester

TKT#	TIME	DAYS	INSTRUCTOR	LOC./RM.	DATES
MATHEMATICS 219H, HONORS STATISTICS & PROBABILITY					
<p>4 UNITS Enhanced format for the beginning course in statistics, using a seminar approach and computers and individual research and presentations, with applications designed around individual interests of students. (Same as Social Science 219H.) Prerequisite: Mathematics 080 or 140 and a high school or college GPA of 3.0 or above.</p>					
6321975	1:00-3:30pm	MW	McClure C	SAC A-213	Full Semester

TKT#	TIME	DAYS	INSTRUCTOR	LOC./RM.	DATES
MATHEMATICS 275, DISCRETE MATHEMATICS II					
<p>3 UNITS Second of two semesters of discrete mathematics needed in computer related disciplines: Graph theory, Boolean Algebra, algebraic structures and linear algebra. Prerequisite: Mathematics 185 and 270 with a grade of C or better.</p>					
6327501	5:30-7:35pm	MW	Sci Staff	SAC H-104	Full Semester

TKT#	TIME	DAYS	INSTRUCTOR	LOC./RM.	DATES
MATHEMATICS 280, INTERMEDIATE CALCULUS (CAN MATH 22) (CAN MATH SEQ C = MATH 180+185+280)					
<p>4 UNITS Vectors and three dimensional space, partial derivatives, multiple integrals and vector analysis. Green's, Stoke's, and divergence theorems. Prerequisite: Mathematics 185 with a grade of C or better.</p>					
6328001	3:30-5:35pm	TTh	Sill K	SAC H-104	Full Semester

TKT#	TIME	DAYS	INSTRUCTOR	LOC./RM.	DATES
------	------	------	------------	----------	-------

MATHEMATICS 295, BEGINNING DIFFERENTIAL EQUATIONS (CAN MATH 24) 4 UNITS
 Theory, techniques, and applications of ordinary differential equations; systems and eigenvalues; computational techniques, Laplace transforms and infinite series solutions. Completion of or concurrent enrollment in Mathematics 290 recommended. Prerequisite: Mathematics 280 with a grade of C or better.
 6329502 3:15-5:20pm TTh Sci Staff SAC R-318 Full Semester

MEDICAL ASSISTANT

MEDICAL ASSISTANT 001, COOPERATIVE WORK EXPERIENCE EDUCATION - OCCUPATIONAL 1-4 UNITS

Must be working for pay or volunteering in a position which includes new or expanded responsibilities and is related to student's major. Limit 16 units in occupational cooperative education courses. Must be enrolled in a minimum of 7 units, including the units for Medical Assistant 001. May be repeated. Grade: CR/NCR only.

6400102 5:00-6:00pm Th Rockoff S SAC R-307 Full Semester

MEDICAL ASSISTANT 020, BLOODBORNE PATHOGEN STANDARDS 0.5 UNITS

Bloodborne pathogen standards for CAL/OSHA occupational exposure to hepatitis and HIV/AIDS, including compliance requirements, exposure control measures, exposure determination, protective equipment, post exposure practices.

6402002 8:00-4:30pm F Rockoff S SAC R-307 3/28-3/28

SUGGESTED SEQUENCING FOR MEDICAL ASSISTANT COURSE:

First Semester: MA 051A, MA 053, MA 054, (MA 020)
 Second Semester: MA 051B, MA 055, (MA 056), (MA 001)

MEDICAL ASSISTANT 051A, BEGINNING MEDICAL TERMINOLOGY 3 UNITS

Introduction to medical terms including structural analysis of prefixes, roots, and suffixes. Emphasis on terms related to structure (anatomy), function (physiology), diagnostic tests and pathology (diseases) of the digestive, renal-urinary, and reproductive systems, including terms related to pregnancy and the newborn.

6405102 8:30-11:40 M Rockoff S SAC R-307 Full Semester
 6405105 9:00-12:10pm T Rockoff S SAC R-228 Full Semester
 6405106 5:30-8:40pm W Fray L SAC B-11 Full Semester
 6405101 6:30-9:40pm Th Seitz C SAC R-113 Full Semester

MEDICAL ASSISTANT 051B, ADVANCED MEDICAL TERMINOLOGY 3 UNITS

Continuation of MA 051A. Includes medical terms related to anatomy (structure), physiology (function), diagnostic tests and pathology of the nervous, cardiovascular, respiratory, circulatory, musculoskeletal, skin, eye, ears, and the endocrine system. Also includes medical terms and abbreviations pertaining to oncology, radiology, nuclear medicine, pharmacology, and psychiatry. Prerequisite: Medical Assistant 051A or equivalent.

6405104 9:00-12:10pm W Rockoff S SAC R-228 Full Semester

MEDICAL ASSISTANT 053, MEDICAL ASSISTANT - ADMINISTRATIVE 3 UNITS

Medical front office training including first aid, medical ethics, etiquette, and law, medical records, filing, billing and collection, banking, bookkeeping, reception, telephone techniques, oral and written communication, resume and job seeking skills.

6405302 6:00-9:10pm T Seitz C SAC G-106 Full Semester

MEDICAL ASSISTANT 054, PREPARATION OF MEDICAL INSURANCE FORMS 3 UNITS

Instruction in completion of medical insurance forms for Medicare, Medi-Cal, Tricare, MediMedi, State Disability, Workers Compensation and private commercial carriers. Includes legal and ethical guidelines, procedure coding and ICD-9-CM.

6405402 6:30-9:40pm M Randles D SAC R-303-1 Full Semester

MEDICAL ASSISTANT 055, MEDICAL ASSISTANT - CLINICAL BACK OFFICE 3 UNITS

Medical back office training including medical asepsis, sterilization procedures, autoclaving, assisting physician with patient exams, taking vital signs, sterile gloving, wound care, dressings, bandaging, specimen collections, the administration of medications and injection techniques.

6405501 6:00-9:10pm Th Coliflores R SAC R-307 Full Semester

MEDICAL ASSISTANT 056, COMPUTER APPLICATIONS FOR THE MEDICAL OFFICE 3 UNITS

An introduction to the computer with practical applications for a medical office/clinical setting, including building patient databases, patient scheduling, procedure codes, and diagnostic codes. Generate computerized billing records, posting to accounts, insurance claims forms, and generating reports and electronic data interchange.

6405601 1:30-4:40pm T Seitz C SAC R-303-1 Full Semester

MEDICAL ASSISTANT PROGRAM



Certificate Program (15 units) Required Courses:
 MA 051A, MA 051B, MA 053, MA 054, MA 055
 (Electives: MA 001, MA 020, MA 056)

TKT#	TIME	DAYS	INSTRUCTOR	LOC./RM.	DATES
------	------	------	------------	----------	-------

MUSIC

MUSIC 011, READING AND MAKING MUSIC 2 UNITS

Introduction to music reading. Practical experience in learning how to perform melodies, rhythms and simple chords from a written score. Suggested for beginning instrumental and voice students, and those who want to know more about music. Recommended as preparation for music theory.

6501101 4:50-6:55pm T Jones E SAC N-117 Full Semester

MUSIC 034A, SONG WRITING WORKSHOP 1 UNIT

Instruction in song writing (words and music) in various styles with students presenting their own songs live or pre-recorded. Ability to notate music not required. Grade: CR/NCR only.

6503404 8:00-10:05pm T Warde L SAC N-105 Full Semester

MUSIC 034B, SONG WRITING WORKSHOP 1 UNIT

Advanced instruction in song writing (words and music). Assignments differ from Music 034A. Songs presented in class. Students encouraged to concurrently enroll in Music 011 or Music 111. May be repeated. Grade: CR/NCR only. Prerequisite: Music 034A.

6503424 8:00-10:05pm T Warde L SAC N-105 Full Semester

MUSIC 047A, BEGINNING ELECTRIC BASS 1 UNIT

Group instruction for beginners on electric bass. Introduction to basics of music notation, rhythm and blues, rock, jazz, and pop styles presented. Lead sheet interpretations are presented with practical performance ideas.

6504701 5:50-7:55pm T Davenport D SAC N-105 Full Semester

MUSIC 047B, INTERMEDIATE ELECTRIC BASS 1 UNIT

Intermediate group instruction on electric bass. Continued technical skills introduced in Music 047A. Includes expanded chord vocabulary, new scales and modes, and introduction to jazz improvisation. Prerequisite: Music 047A.

6504721 5:50-7:55pm T Davenport D SAC N-105 Full Semester

MUSIC 061, BASIC PIANO SKILLS 1 1 UNIT

Class piano for beginners emphasizing note reading, basic keyboard skills, and sight reading. Practice outside of class required. Practice pianos available on campus. Grade: CR/NCR only.

6506103 9:00-10:55 MW Kehlenbach E SAC N-106 4/14-6/4
 6506107 10:00-12:05pm S O'Hern E SAC N-106 Full Semester
 6506101 12:30-1:25pm TTh Tseng P SAC N-106 Full Semester
 6506110 1:30-2:25pm MW Blake P SAC N-106 Full Semester
 6506102 5:50-7:55pm T Kim J SAC N-106 Full Semester
 6506109 7:00-9:05pm M Tseng P SAC N-106 Full Semester
 6506104 7:00-9:05pm Th Kim J SAC N-106 Full Semester

MUSIC 071, SYMPHONIC BAND 1 UNIT

Rehearsal and performance of standard band music for performance in the community. Each semester requires performance of a variety of new and different repertoire. Designed for students with basic performance skills. May be repeated. Grade: CR/NCR only.

6507101 7:00-10:10pm W Lopez D SAC N-114 2/20-5/28

MUSIC 101, MUSIC APPRECIATION 3 UNITS

Designed to increase awareness and appreciation of music from the European classical tradition in relation to general culture and history. Develops basic understanding of musical elements and deepens students' experience of music through video, films and recordings. Recommended for non-music majors.

6510107 8:00-9:25 TTh Davenport D SAC N-117 Full Semester
 6510159 9:00-1:35pm TWTTh O'Hern E SAC N-117 1/8-1/31
 6510101 9:30-10:55 TTh Kim J SAC C-104 Full Semester
 6510102 11:00-12:25pm MW Hung G SAC C-104 Full Semester
 6510104 7:00-10:10pm T O'Hern E SAC C-104 Full Semester
 6510199 Hrs Arr Jones E SAC WEB Full Semester

(This is a hybrid in-class and online course. Mandatory class meetings will be on campus Feb 22, 29, Mar 14, Apr 4, May 2, 23, 6:30-9:30pm, SAC N-117. Attendance at all campus meetings is mandatory. See Online Courses page in class schedule or go to www.sac.edu/disted for more information.)

MUSIC 101H, HONORS MUSIC APPRECIATION 3 UNITS

Enriched for honors. European classical music tradition through study of musical elements, stylistic features, culture and history. Readings, guided listening assignments, required concert attendance and special projects. Recommended for non-music majors. Prerequisite: A high school or college GPA of 3.0 or above.

6510150 11:00-12:25pm TTh Jones E SAC N-117 Full Semester

MUSIC 102H, HONORS WORLD MUSIC 3 UNITS

Enriched, in-depth study of music from Asia, Africa, the Middle East, Europe and the Americas. Seminar-style critical investigation of the interconnections of style, culture and aesthetics to promote enjoyment and understanding of world musics. Prerequisite: High School or college GPA of 3.0 or above.

6510201 6:00-9:10pm W Brener D SAC N-105 Full Semester

MUSIC 103, JAZZ IN AMERICA 3 UNITS

A historical survey of the development and evolution of jazz in America from its earliest roots in African and European music. The study will also include the social and economic conditions which influenced this art form.

6510399 9:00-1:05pm TWTTh Jackson M SAC N-114 1/8-1/31
 6510301 9:30-10:55 MW Jackson M SAC N-114 Full Semester
 6510302 9:30-10:55 TTh Lopez D SAC N-114 Full Semester
 6510305 7:00-10:10pm M Bush N SAC D-105 Full Semester
 6510304 7:00-10:10pm Th Otwell C SAC C-104 Full Semester

TKT#	TIME	DAYS	INSTRUCTOR	LOC./RM.	DATES
------	------	------	------------	----------	-------

MUSIC 110, FUNDAMENTALS OF MUSIC**3 UNITS**

Music is explored through lecture, written exercises, melodic and rhythmic performance, and composition. Stresses practical skills necessary for performance. Prepares students for the study of harmony and arranging by examining scales, intervals and chords. Ability to read music in at least one clef is advised.

6511001	11:00-12:25pm	MW	Blake P	SAC N-117	Full Semester
---------	---------------	----	---------	-----------	---------------

MUSIC 111, BASIC THEORY AND EAR TRAINING**4 UNITS**

Beginning level computer assisted course to learn skills of hearing and notating melodies and chords. Detailed study of rhythm, meter, scales, intervals and beginning harmony. Ability to read music in at least one clef recommended. Required of music majors; open to non-majors.

6511102	11:00-12:55pm	MW	Blake P	SAC N-117	Full Semester
AND	1 Hr Arr		Blake P	SAC N-119	
6511101	6:00-10:15pm	Th	Marr J	SAC N-114	Full Semester
AND	1 Hr Arr		Marr J	SAC N-119	

MUSIC 112, THEORY 2**4 UNITS**

Continued study of harmonic techniques and ear training. Includes chord symbols, harmonization of melodies, and writing phrases. Computer assisted. Required for music majors; open to non-majors. Prerequisite: Music 111.

6511201	6:00-10:10pm	Th	Kehlenbach E	SAC N-117	Full Semester
AND	1 Hr Arr		Kehlenbach E	SAC N-119	

MUSIC 113A, BASIC MUSICIANSHIP SKILLS**1 UNIT**

Preparation in ear training/sightsinging skills for Music 114A. In-class sightsinging. Arranged hours in Music Lab use computers and ear training CD's. Basic knowledge of scales and intervals recommended. Grade: CR/NCR only.

6511301	5:00-5:55pm	Th	Marr J	SAC N-106	Full Semester
AND	1 Hr Arr		Blake P	SAC N-119	

MUSIC 113B, MUSICIANSHIP SKILLS**1 UNIT**

Preparation in ear training/sightsinging skills for Music 114A. In-class sightsinging. Arranged hours in Music Lab use computers and ear training CD's. Basic knowledge of scales and intervals recommended. Different materials in B semester. Grade: CR/NCR only. Prerequisite: Music 113A.

6511321	5:00-5:55pm	Th	Marr J	SAC N-106	Full Semester
AND	1 Hr Arr		Blake P	SAC N-119	

MUSIC 114A, MUSICIANSHIP**1 UNIT**

Competency-based sightsinging, ear training, melodic/harmonic dictation for performers and transferring music majors. Arranged hours use computer programs/aural tapes. Prerequisite: Music 112.

6511401	6:00-6:55pm	Th	Blake P	SAC N-105	Full Semester
AND	2 Hrs Arr		Marr J	SAC N-119	

MUSIC 114B, MUSICIANSHIP**1 UNIT**

Competency-based sightsinging, ear training, melodic/harmonic dictation for performers and transferring music majors. Arranged hours use computer programs/aural tapes. More advanced materials in B semester. Prerequisite: Music 114A.

6511421	6:00-6:55pm	Th	Blake P	SAC N-105	Full Semester
AND	2 Hrs Arr		Marr J	SAC N-119	

APPLIED MUSIC - MUSIC 115

New Students interested in Applied Music instruction should attend the orientation meeting Tues, Feb 12, 5-6pm, SAC C-104. Auditions and other program requirements will be discussed. For more information, call 564-5655.

MUSIC 115A, APPLIED MUSIC (PRIVATE INSTRUCTION)**0.5-1 UNIT**

Weekly lesson in voice, piano, band/orchestra instrument or classical guitar. Must attend weekly recital and practice 5 hours per week in Music Building. Open entry/open exit. Prerequisite: Audition and concurrent enrollment in one music course.

6511501	7 Hrs Arr		Jones J	SAC N-117	Full Semester
---------	-----------	--	---------	-----------	---------------

MUSIC 115B, APPLIED MUSIC (PRIVATE INSTRUCTION)**0.5-1 UNIT**

Weekly lesson in voice, piano, band/orchestra instrument or classical guitar. Must attend weekly recital and practice 5 hours per week in Music Building. Open entry/open exit. Prerequisite: Audition and concurrent enrollment in one music course.

6511521	7 Hrs Arr		Jones J	SAC N-117	Full Semester
---------	-----------	--	---------	-----------	---------------

TKT#	TIME	DAYS	INSTRUCTOR	LOC./RM.	DATES
------	------	------	------------	----------	-------

MUSIC 115C, APPLIED MUSIC (PRIVATE INSTRUCTION)**0.5-1 UNIT**

Weekly lesson in voice, piano, band/orchestra instrument or classical guitar. Must attend weekly recital and practice 5 hours per week in Music Building. Open entry/open exit. Prerequisite: Audition and concurrent enrollment in one music course.

6511541	7 Hrs Arr		Jones J	SAC N-117	Full Semester
---------	-----------	--	---------	-----------	---------------

MUSIC 115D, APPLIED MUSIC (PRIVATE INSTRUCTION)**0.5-1 UNIT**

Weekly lesson in voice, piano, band/orchestra instrument or classical guitar. Attend weekly recital and 5 hours weekly practice in Music Building. Open entry/open exit. Prerequisite: Audition and concurrent enrollment in any music course.

6511561	7 Hrs Arr		Jones J	SAC N-117	Full Semester
---------	-----------	--	---------	-----------	---------------

MUSIC 121, BEGINNING VOICE**1 UNIT**

Group instruction for beginners emphasizing basic principles of solo and choral vocal production, diction, breath control and posture. Practice outside of class required. Recommended for non music majors and music majors not studying privately.

6512105	1:00-1:55pm	MW	Jones E	SAC N-117	Full Semester
6512104	1:00-1:55pm	TTh	O'Hern E	SAC N-117	Full Semester
6512103	6:00-7:55pm	W	Jones E	SAC N-117	Full Semester

MUSIC 122, INTERMEDIATE VOICE**1 UNIT**

Group instruction designed to develop intermediate principles of solo and choral vocal production, diction, breath control and posture. Practice outside of class required. Recommended for non music majors and for music majors not studying privately. Prerequisite: Music 121.

6512205	1:00-1:55pm	MW	Jones E	SAC N-117	Full Semester
6512204	1:00-1:55pm	TTh	O'Hern E	SAC N-117	Full Semester
6512203	6:00-7:55pm	W	Jones E	SAC N-117	Full Semester

MUSIC 123, ADVANCED VOICE**1 UNIT**

Advanced principles of solo and choral vocal production. Includes vocal exercises and song literature in English and other languages. Practice outside of class required. Recommended for non music majors and for music majors not studying privately. Prerequisite: Music 122.

6512305	1:00-1:55pm	MW	Jones E	SAC N-117	Full Semester
6512304	1:00-1:55pm	TTh	O'Hern E	SAC N-117	Full Semester
6512303	6:00-7:55pm	W	Jones E	SAC N-117	Full Semester

MUSIC 124, ADVANCED VOCAL PRODUCTION AND REPERTOIRE**1 UNIT**

Continues group instruction for those who have completed 3 semesters of voice. Emphasizes advanced vocal production, repertoire and technique. Practice outside of class required. Recommended for non music majors and music majors not studying privately. Prerequisite: Music 123.

6512405	1:00-1:55pm	MW	Jones E	SAC N-117	Full Semester
6512404	1:00-1:55pm	TTh	O'Hern E	SAC N-117	Full Semester
6512403	6:00-7:55pm	W	Jones E	SAC N-117	Full Semester

MUSIC 132, THE JAZZ SINGERS**1 UNIT**

Rehearsal and performance of vocal jazz and popular compositions and arrangements. Performance is emphasized. Each semester requires a variety of new and different repertoire. May be repeated. Prerequisite: Audition.

6513202	6:30-8:35pm	M	Kelley C	SAC N-105	Full Semester
AND	1 Hr Arr		Kelley C	SAC N-105	

MUSIC 134, VOCAL JAZZ WORKSHOP**1 UNIT**

Training in vocal jazz ensemble singing styles utilizing standard and current arrangements. Each semester requires performance of a variety of new repertoire. May be repeated.

6513402	6:30-8:35pm	M	Kelley C	SAC N-105	Full Semester
AND	1 Hr Arr		Kelley C		

MUSIC 135, CONCERT CHORALE**1 UNIT**

Training in mixed ensemble singing of standard and current choral repertoire. Public performance emphasized. Each semester requires performance of a variety of new and different repertoire. Designed for students who have basic singing skills. May be repeated.

6513501	2:00-3:25pm	MW	Jones E	SAC N-117	Full Semester
AND	1.5 Hrs Arr		Jones E	SAC N-117	
6513503	7:00-10:10pm	T	Jones E	SAC N-117	Full Semester
AND	1.5 Hrs Arr		Jones E	SAC N-117	

MUSIC 136, COLLEGIATE CHOIR**1 UNIT**

Mixed chorus which rehearses and performs a variety of music, including classical, folk tunes and songs from Broadway musicals. Limited daytime performances. Each semester requires performance of a variety of new repertoire. May be repeated. Grade: CR/NCR only.

6513601	2:00-3:25pm	MW	Jones E	SAC N-117	Full Semester
6513603	7:00-10:10pm	T	Jones E	SAC N-117	Full Semester

MUSIC 137, CHAMBER CHOIR**1 UNIT**

Rehearsal and performance of standard and current chamber choir repertoire. Course designed for off-campus competitions and formal on campus performance. Each semester requires the performance of a variety of new repertoire. May be repeated. Prerequisite: Audition.

6513701	3:30-4:55pm	MW	Jones E	SAC N-117	Full Semester
---------	-------------	----	---------	-----------	---------------

MUSIC 141, INSTRUMENTAL ENSEMBLES**1 UNIT**

Study, rehearsal and performance of music for small commercial instrumental groups. Music literature will differ each semester. May be repeated. Prerequisite: Previous playing experience and audition.

6514101	3:30-4:55pm	MW	Jones E	SAC N-117	Full Semester
---------	-------------	----	---------	-----------	---------------

Can't find the class you need?

**It may be waiting for you at
Santiago Canyon College!**

**View SCC's class schedule at
www.scccollege.edu/schedule**

SCC's class schedule is included in this booklet.

Hurry! Class sizes are limited.

TKT#	TIME	DAYS	INSTRUCTOR	LOC./RM.	DATES
------	------	------	------------	----------	-------

TKT#	TIME	DAYS	INSTRUCTOR	LOC./RM.	DATES
------	------	------	------------	----------	-------

Instrumental and Vocal Ensembles at SAC

Concert Choir, Music 135
Chamber Choir, Music 137
Vocal Jazz Workshop, Music 134
Concert Band, Music 171
Woodwind Ensemble, Music 172
Percussion Ensemble, Music 174
The Jazz Ensemble, Music 175
Latin Jazz Ensemble, Music 177
'Don' Mariachi, Music 178
Chamber Orchestra, Music 181
Guitar Ensemble, Music 189

For more information on instrumental classes contact David Lopez, 564-5652.

MUSIC 142, CREATING MUSIC WITH MIDI 1 UNIT

Basic techniques in creating music with computer assisted technology including MIDI sequencing, drum track programming, editing, mixdown and use of tone modules. Students learn MIDI applications through musical projects. Basic skill level on keyboard suggested.

6514203	1:00-1:55pm	MW	Kehlenbach E	DMC-204	2/11-4/2
AND	2 Hrs Arr		Kehlenbach E		

MUSIC 144, PROJECTS IN ELECTRONIC MUSIC 1 UNIT

Exploration of the skills necessary to arrange music on the computer/MIDI workstation for commercial applications. Individual projects will improve and extend students' electronic skills in the areas of composition, sequencing, and recording. May be repeated. Prerequisite: Music 143 or 147.

6514403	1:00-1:55pm	MW	Kehlenbach E	DMC-204	2/11-4/2
AND	4 Hrs Arr		Kehlenbach E		
6514402	1:00-2:25pm	MW	Kehlenbach E	DMC-204	4/14-6/4
AND	3 Hrs Arr		Kehlenbach E	DMC-204	
6514401	6:00-9:05pm	W	Graham A	DMC-204	4/16-6/4
AND	4 Hrs Arr		Graham A		

MUSIC 145, JAZZ IMPROVISATION AND PERFORMANCE WORKSHOP 1 UNIT

Performance and analysis of jazz standards and popular pieces in a practical workshop setting. Elements of improvisation and ensemble playing are stressed. Assumes a rudimentary understanding of chords and scales. Open to all instrumentalists and vocalists. May be repeated.

6514501	10:00-12:05pm	F	Kehlenbach E	SAC N-114	Full Semester
---------	---------------	---	--------------	-----------	---------------

MUSIC 146, DIGITAL RECORDING STUDIO TECHNIQUES I 2 UNITS

Introductory class in computer-based hard disk recording. Emphasis on digital sound manipulation, editing, mixdown, and microphone techniques. May be repeated.

6514602	1:30-2:55pm	TTh	Bush N	DMC-204	2/12-4/3
AND	3 Hrs Arr		Bush N	DMC-204	
6514601	6:00-9:05pm	W	Graham A	DMC-204	2/13-4/2
AND	3 Hrs Arr		Graham A	DMC-204	

MUSIC 147, DIGITAL RECORDING STUDIO TECHNIQUES II 2 UNITS

Continuation of Digital Recording Studio Techniques I. Further study of digital sound manipulation including digital effects, compression, equalization editing on a digital mixer, live recording techniques and CD production. May be repeated. Prerequisite: Music 146.

6514702	1:30-2:55pm	TTh	Bush N	DMC-204	4/15-6/5
AND	3 Hrs Arr		Bush N	DMC-204	
6514701	6:00-9:05pm	W	Graham A	DMC-204	4/16-6/4
AND	3 Hrs Arr		Graham A		

MUSIC 148, DIGITAL MUSIC SYNCHRONIZATION TO MULTIMEDIA 2 UNITS

Techniques of synchronizing MIDI and digital audio tracks to video. Compositional elements of scoring to picture as well as technical elements of using SMPTE time code are covered. Experience with MIDI sequencing and/or digital recording is necessary. May be repeated.

6514801	1:00-2:25pm	MW	Kehlenbach E	DMC-204	4/14-6/4
AND	3 Hrs Arr		Kehlenbach E	DMC-204	

MUSIC 149, THE BUSINESS OF MUSIC 2 UNITS

Introduction to the business and legal aspects of the music industry. This course covers trends and issues for performing and recording careers in music. Topics include copyright, royalties, recording contracts, performing rights organizations, publishing, and publicity.

6514901	6:00-8:05pm	T	Jackson M	DMC-203	Full Semester
---------	-------------	---	-----------	---------	---------------

MUSIC 161, CLASS PIANO I 1 UNIT

Group instruction for beginners emphasizing note reading, basic keyboard skills, chord patterns, and sight reading. Practice outside of class required. Practice pianos available on campus. Required for music majors whose principal instrument is not piano.

6516104	9:00-10:55	MW	Kehlenbach E	SAC N-106	4/14-6/4	
W	6516106	10:00-12:05pm	S	O'Hern E	SAC N-106	Full Semester
	6516101	12:30-1:25pm	TTh	Tseng P	SAC N-106	Full Semester
	6516110	1:30-2:25pm	MW	Blake P	SAC N-106	Full Semester
	6516102	5:50-7:55pm	T	Kim J	SAC N-106	Full Semester
	6516109	7:00-9:05pm	M	Tseng P	SAC N-106	Full Semester
	6516103	7:00-9:05pm	Th	Kim J	SAC N-106	Full Semester

MUSIC 162, CLASS PIANO II 1 UNIT

Class piano for second semester beginning students. Note reading, keyboard technique, chord patterns, sight reading. Practice pianos available on campus. Required for music majors whose principal instrument is not piano. Prerequisite: Music 061 or 161.

6516201	11:00-11:55	TTh	Blake P	SAC N-106	Full Semester
6516202	6:00-8:05pm	W	Martinchuk S	SAC N-106	Full Semester

MUSIC 163, CLASS PIANO III 1 UNIT

Intermediate instruction for students who have completed two semesters of piano. Emphasizes building technique, sight reading, and performance. Practice pianos available on campus. Prerequisite: Music 162.

6516301	11:30-12:25pm	TTh	Blake P	SAC N-106	Full Semester
6516302	7:00-9:05pm	W	Martinchuk S	SAC N-106	Full Semester

MUSIC 164A, INTERMEDIATE PIANO REPERTOIRE I 1 UNIT

Instruction for intermediate level students. Emphasizes solo material, technique, sight reading interpretation and performance. Prerequisite: Music 163.

6516401	7:00-9:05pm	W	Martinchuk S	SAC N-106	Full Semester
---------	-------------	---	--------------	-----------	---------------

MUSIC 164B, INTERMEDIATE PIANO REPERTOIRE II 1 UNIT

Continuation of instruction at advanced intermediate level. Emphasizes solo material, technique, sight reading interpretation and performance. Prerequisite: Music 164A.

6516411	7:00-9:05pm	W	Martinchuk S	SAC N-106	Full Semester
---------	-------------	---	--------------	-----------	---------------

MUSIC 165, BEGINNING FOLK GUITAR 1 UNIT

Instruction in beginning guitar covering basic playing skills. No previous knowledge of music required. Student must furnish six-string guitar (nylon strings preferred.)

W	6516502	10:00-12:05pm	S	Merrill L	SAC N-117	Full Semester
---	---------	---------------	---	-----------	-----------	---------------

MUSIC 171, CONCERT BAND 1 UNIT

Study and rehearsal of band music for concert performances on campus and in the community. Each semester requires performance of new and different repertoire. Designed for students with basic performance skills. May be repeated.

6517101	7:00-10:10pm	W	Lopez D	SAC N-114	2/20-5/28
---------	--------------	---	---------	-----------	-----------

MUSIC 172, WOODWIND ENSEMBLE 1 UNIT

Rehearsal and performance of repertoire for woodwind ensemble. Each semester requires the performance of a variety of different repertoire. Designed for students who have basic performance skills. May be repeated.

6517202	4:50-6:55pm	W	Lopez D	SAC P-114	Full Semester
AND	1 Hr Arr		Lopez D		

MUSIC 173, BEGINNING RHYTHMS IN PERCUSSION AND DRUMS 1 UNIT

The introduction of snare drum and drum set in a class situation. Designed to teach the basics of percussion and drum set performance for the beginning student. Emphasis on rhythmic reading, rudimental techniques and basic drum set coordination in various styles. May be repeated.

6517301	4:50-6:55pm	W	Sqyres D	SAC N-114	Full Semester
---------	-------------	---	----------	-----------	---------------

MUSIC 174, PERCUSSION ENSEMBLE 1 UNIT

Rehearsal and performance of music for percussion ensemble. Each semester requires the performance of a variety of different repertoire. Designed for students who have basic performance skills. May be repeated.

6517402	4:50-6:55pm	M	Sqyres D	SAC N-114	Full Semester
AND	1 Hr Arr		Lopez D		

MUSIC 175, JAZZ ENSEMBLE 1 UNIT

Study, rehearsal and performance of contemporary jazz/rock music with help in developing techniques of improvisation. Each semester requires performance of new and different jazz repertoire. Designed for students with basic performance skills. May be repeated.

6517501	7:00-10:10pm	M	Lopez D	SAC N-114	2/18-6/9
---------	--------------	---	---------	-----------	----------

MUSIC 176, JAZZ BAND 1 UNIT

Advanced study, rehearsal and performance of standard and contemporary jazz literature. Includes advanced techniques in improvisation. Each semester requires performance of new and different repertoire. Designed for students with basic performance skills. May be repeated.

6517601	7:00-10:10pm	M	Lopez D	SAC N-114	2/18-6/9
---------	--------------	---	---------	-----------	----------

MUSIC 177, LATIN JAZZ ENSEMBLE 1 UNIT

Rehearsal and performance of jazz repertoire with influences from the Caribbean, Brazil, and Latin America. Each semester requires the performance of a variety of different repertoire. Designed for students who have basic performance skills. May be repeated.

6517702	2:30-4:35pm	M	Lopez D	SAC N-114	Full Semester
AND	1 Hr Arr		Lopez D		

TKT#	TIME	DAYS	INSTRUCTOR	LOC./RM.	DATES
MUSIC 178, MARIACHI 1 UNIT					
Mixed ensemble for the study, rehearsal and performance of Mariachi repertoire with an emphasis on the music from Jalisco. Each semester requires the performance of a variety of different repertoire. Designed for students who have basic performance skills. May be repeated.					
6517802	2:50-4:55pm	Th	Lopez D	SAC N-114	Full Semester
AND 1 Hr Arr Lopez D					
MUSIC 179, TECHNIQUE STUDIES FOR PIANISTS 1 UNIT					
Group study of scales, arpeggios, and exercises to increase finger agility and keyboard control. Suggested concurrent enrollment with Music 164AB or applied piano studies in Music 115. Not for beginners. May be repeated. Prerequisite: Music 163.					
6517901	11:00-11:55	TTh	Israel R	SAC N-106	Full Semester
MUSIC 180, STRING METHODS 1 UNIT					
Instruction on violin, viola, cello or string bass in an ensemble setting at the beginning and intermediate levels. Fundamental skills developed through rehearsal and in-class performance of technical exercises and beginning orchestral repertoire. May be repeated.					
6518002	7:00-9:05pm	T	Hung G	SAC N-114	2/19-6/3
MUSIC 181, CHAMBER ORCHESTRA 1 UNIT					
Rehearsal and performance of standard repertoire for chamber orchestra. Each semester requires the performance of a variety of different repertoire. Designed for students who have basic performance skills. May be repeated.					
6518101	7:00-10:10pm	T	Hung G	SAC N-114	2/19-6/3
MUSIC 185, BEGINNING CLASSICAL GUITAR 1 UNIT					
Guitar playing techniques of right hand and left hand fingers. Development of correct finger usage. Basic instruction in reading staff notation and relating staff notation to practical playing. Student must furnish nylon string guitar.					
W 6518503	10:00-12:05pm	S	Adele D	SAC N-114	Full Semester
6518501	5:50-7:55pm	M	Giralдин M	SAC N-117	Full Semester
MUSIC 186, INTERMEDIATE CLASSICAL GUITAR 1 UNIT					
Intermediate instruction in solo, duo and trio repertoire. Emphasizes technique studies and performance styles of 18th century music. Student must provide nylon string guitar. May be repeated. Prerequisite: Music 185.					
6518601	8:00-10:05pm	M	Giralдин M	SAC N-117	Full Semester
MUSIC 187, ADVANCED CLASSICAL GUITAR 1 UNIT					
Instruction at advanced level in solo, duo and trio repertoire. Emphasizes advanced technical studies and etudes and performance styles of 16th through 20th century music. Student must provide nylon string guitar. May be repeated. Prerequisite: Music 186.					
6518701	8:00-10:05pm	M	Giralдин M	SAC N-117	Full Semester
MUSIC 188, ADVANCED CLASSICAL GUITAR TECHNIQUE AND REPERTOIRE 1 UNIT					
Further develops advanced technique and solo performance through study of ornamentation and various performance styles of 16th through 20th century music. Student must provide nylon string guitar. May be repeated. Prerequisite: Music 187.					
6518801	8:00-10:05pm	M	Giralдин M	SAC N-117	Full Semester
MUSIC 189, GUITAR ENSEMBLE 1 UNIT					
Rehearsal and performance of standard and current repertoire for guitar ensemble. Each semester requires the performance of a variety of different repertoire. Designed for students who have basic performance skills. May be repeated.					
W 6518901	12:15-2:25pm	S	Adele D	SAC N-114	Full Semester
AND 1 Hr Arr Adele D SAC N-114					
MUSIC 198, INTRODUCTION TO PROTOOLS 1.5 UNITS					
Fundamental features and applications of ProTools audio software used in post-production for television, film and music. Orientation to functions, user interface and actual operation of digital audio workstation. Techniques and aesthetics associated with creation of well-mixed soundtracks are addressed. Hands-on practice with digital recording and editing of soundtracks. (Same as Television/Video Communications 198.)					
6519811	6:00-9:30pm	TWTh	Graham A	DMC-204	1/8-1/31
MUSIC 211, MUSIC HISTORY AND LITERATURE 3 UNITS					
Survey of important European trends in musical style and form from the Middle Ages to the 20th Century. Required for music majors. Open to non-music majors.					
6521101	Hrs Arr		Jones E	SAC WEB	Full Semester
(This is a hybrid in-class and online course. Mandatory class meetings will be on campus Feb 22, 29, Mar 14, Apr 4, May 2, 23, 6:30-9:30pm, SAC N-117. Attendance at all campus meetings is mandatory. See Online Courses page in class schedule or go to www.sac.edu/disted for more information.)					
MUSIC 214, THEORY 4 3 UNITS					
Continuation of Music 213. Late 19th century harmonic technique and important aspects of 20th century style. Keyboard harmony. Concurrent enrollment in Music 114B recommended. Required for music majors; open to non-majors. Prerequisite: Music 213.					
6521401	7:00-10:10pm	Th	Blake P	SAC N-105	Full Semester

TKT#	TIME	DAYS	INSTRUCTOR	LOC./RM.	DATES
MUSIC 215A, APPLIED MUSIC (ADVANCED PRIVATE INSTRUCTION) 1 UNIT					
Weekly lesson in voice, piano, band/orchestra instrument or classical guitar. Must attend weekly recital and practice 5 hours per week in the Music Building. Prerequisite: Audition and concurrent enrollment in one music course.					
6521501	7 Hrs Arr		Jones J	SAC N-117	Full Semester
MUSIC 216, ADVANCED HARMONY AND COMPOSITION I 3 UNITS					
Emphasizes effective writing for the keyboard. Introduces simple contrapuntal techniques and combining words with music. Prerequisite: Music 214.					
6521601	7:00-10:10pm	Th	Blake P	SAC N-105	Full Semester
MUSIC 217, ADVANCED HARMONY AND COMPOSITION II 3 UNITS					
Extension of Music 213 and Music 214 harmonic studies into complete small compositions. Emphasizes development technique. Explores highly chromatic harmony, dissonance, and selected 20th century styles. Prerequisite: Music 214.					
6521701	7:00-10:10pm	Th	Blake P	SAC N-105	Full Semester
MUSIC 241, CHAMBER MUSIC ENSEMBLE 1 UNIT					
Rehearsal and performance of music for small groups of strings, woodwinds, brass, percussion, and keyboard instruments in varying combinations. Each semester requires performance of new repertoire. Designed for students with basic performance skills. May be repeated.					
W 6524103	12:15-2:25pm	S	Adele D	SAC N-114	Full Semester
W 6524102	7:00-10:10pm	T	Hung G	SAC N-114	2/19-6/3

NURSING-CONTINUING EDUCATION

NURSING-CONTINUING EDUCATION 098, PREPARATION FOR THE REPEATING NCLEX-RN TEST TAKER 3 UNITS					
Provides a process for test taking and to prepare the student to pass the NCLEX-RN exam. This course is designed to assist graduates of U.S. and foreign schools of nursing that have taken the NCLEX-RN and have not been successful-proof required. May be repeated. Grade: CR/NCR only.					
6709802	5:30-9:35pm	TW	Simbro T	SJH	2/26-6/4
AND 2.5 Hrs Arr Simbro T SJH					
(50 computer lab hours required)					
NURSING-CONTINUING EDUCATION 098, NCLEX-RN EXAM PREPARATION COURSE FOR THE GRADUATE NURSE 1 UNIT					
Provides the student with a process for test taking and to prepare the student to successfully pass the NCLEX-RN exam. This course is designed for graduates of accredited schools of nursing. May be repeated. Grade: CR/NCR only.					
6709801	9:00-2:00pm	MTWThF	Simbro T	SAC R-307	1/7-1/18
AND 1 Hr Arr Simbro T SAC R-307					
(20 computer lab hours required)					
NURSING-CONTINUING EDUCATION 145, ADVANCED CARDIAC LIFE SUPPORT 1.5 UNITS					
Examines advanced principles of caring for patients experiencing cardiopulmonary emergencies. Includes arrhythmic recognition, performance of psychomotor skills and major resuscitation medications. Current BLS card and registration fee required. Contact Skills Lab at (714) 564-6829 BEFORE registration. May be repeated. Grade: CR/NCR only. Prerequisite: Nursing-Registered 201 and 201L or 202 and 202L.					
6714501	9:00-4:10pm	TTh	Nick J	SAC R-307	1/15-1/24
(To register for this class, contact JoAnn Nick 714-564-6829)					

NURSING-REGISTERED

NURSING-REGISTERED 045, CARDIOPULMONARY RESUSCITATION RECERTIFICATION 0.2 UNITS					
To provide updated information and skills training in Basic Life Support for healthcare providers. Open entry/open exit. May be repeated. Grade: CR/NCR only. Prerequisite: Concurrent enrollment in Registered Nursing, EMT, or RN Re-entry.					
6804501	Hrs Arr		Nick J	SAC R-203	Full Semester
NURSING-REGISTERED 101, NURSING PROCESS: NON-CRITICAL ADULTS 4.5 UNITS					
Emphasizes nursing process in the care of adult and geriatric patients of diverse cultures with non-critical biological and psychosocial system needs deficits. Prerequisite: Concurrent enrollment in Nursing-Registered 101L and completion of admission requirements in Nursing-Registered Nursing Program..					
6810101	9:30-11:45	W	Schroeder B	SAC R-307	Full Semester
AND 2:00-4:15pm Th Rehm A SAC R-307					
(ALL Registered Nursing 101 students are to contact ATI at www.attesting.com to pay the required \$105 testing fee)					
NURSING-REGISTERED 101L, NURSING ACTIONS: NON-CRITICAL ADULTS 5 UNITS					
Clinical experience emphasizing nursing process for adults including geriatric patients with non-critical biological system needs. Focuses on psychomotor skills and application. Grade: CR/NCR only. Prerequisite: Concurrent enrollment in Nursing-Registered 101 and completion of admission requirements in Nursing-Registered Nursing Program..					
6810151	240 Hrs Arr		Schroeder B	CARE	2/11-5/27
6810152	240 Hrs Arr		Paunovic M	CARE	2/11-5/27
6810153	240 Hrs Arr		Rehm A	L VH	2/11-5/27
6810154	240 Hrs Arr		Coliflores R	NNR	2/11-5/27
(ALL Registered Nursing students must obtain full scheduling information from the Nursing Office, SAC R-213)					

Academic Planning Questions?
www.sac.edu/online_counseling

TKT#	TIME	DAYS	INSTRUCTOR	LOC./RM.	DATES
------	------	------	------------	----------	-------

NURSING-REGISTERED 102, NURSING PROCESS: WOMEN, PARENTS, AND CHILDREN 4 UNITS

Emphasizes nursing process for women, parents, children of diverse cultures, and community-based nursing. Prerequisite: Nursing-Registered 101, 101L, 103, 112, concurrent enrollment in 102L.

6810201	2:00-4:05pm	W	Ettinger B	SAC R-124	Full Semester
AND	2:00-4:10pm	Th	Lally M	SAC D-106	
6810202	6:00-9:05pm	Th	Ettinger B	SJH	2/11-6/26

(ALL Registered Nursing 102 students are to contact ATI at www.atitesting.com to pay the required \$81 testing fee)

NURSING-REGISTERED 102L, NURSING ACTIONS: WOMEN, PARENTS & CHILDREN 4.6 UNITS

Clinical laboratory experience emphasizing the nursing process in the care of women, parents and children of diverse cultures with biological and psychosocial system need deficits. Application of the nursing process in acute care and community-based settings. Focus is on the application of the biological and psychosocial theoretical concepts in clinical practice. Grade: CR/NCR only. Prerequisite: Nursing-Registered 101, 101L, 103, 112; concurrent enrollment in Nursing-Registered 102.

6810251	220 Hrs Arr	T	Sci Staff	SJH	Full Semester
6810252	220 Hrs Arr	M	Ettinger B	FVRH	Full Semester
6810253	220 Hrs Arr	M	Lally M	WMC	Full Semester
6810254	220 Hrs Arr	T	Weinfeld J	GGH	Full Semester
6810261	220 Hrs Arr	S	Bass S	SJH	2/11-6/14
6810262	220 Hrs Arr	S	Holliday C	GGH	2/11-6/14
6810263	220 Hrs Arr	S	Giroux R	WMC	2/11-6/14

(ALL Registered Nursing students must obtain full scheduling information from the Nursing Office, SAC R-213. ONLY students enrolled in the Extended Campus Program may register for Tckt No's 6810261, 6810262, 6810263.)

NURSING-REGISTERED 103, PHARMACOLOGICAL CONCEPTS OF NURSING 2 UNITS

Introduction to pharmacology, dosage calculations, drug classifications and application of nursing process to drug administration. Completion required prior to entry into Nursing Registered 102/102L. Prerequisite: English 101, Biology 149 or 239, Biology 249, Biology 139 or 229.

6810301	3:00-5:05pm	W	Paunovic M	SAC R-128	Full Semester
(N-RN 103 to be taken no sooner than within 1 year of entering the Nursing Program)					
6810302	Hrs Arr		Paunovic M	SAC WEB	Full Semester

(Nursing Registered 103, Tckt No 6810302 combines online and on-campus instruction.)

MANDATORY orientation, 3-5:05pm, Feb 13, SAC R-128. Testing dates to be arranged. See Online Courses page in class schedule or go to www.sac.edu/students/online_classes for more information. N-RN 103 to be taken no sooner than within 1 year of entering the Nursing Program.)

NURSING-REGISTERED 105, COOPERATIVE WORK EXPERIENCE EDUCATION-OCCUPATIONAL 1-4 UNITS

Supervised paid or volunteer experience in student's major including new or expanded responsibilities. Must enroll in 7 units. Limit of 16 units in occupational cooperative education courses. May be repeated. Grade: CR/NCR only. Prerequisite: Concurrent enrollment in Nursing-Registered 201L or 202L.

6810501	33 Hrs Arr		Simbro T	SJH	Full Semester
---------	------------	--	----------	-----	---------------

NURSING-REGISTERED 112, NURSING CONCEPTS 1.5 UNITS

Emphasizes development of the registered nurse including role, communication, nursing process, legal and ethical concepts, test taking strategies, the Santa Ana College Conceptual Framework for Nursing, nutrition and medical terminology. Completion required prior to entry into Nursing-Registered 102/102L. Prerequisite: English 101, Biology 149 or Biology 239, Biology 249, Biology 139 or 229.

6811201	Hrs Arr		Brown S	SAC WEB	Full Semester
---------	---------	--	---------	---------	---------------

(Tckt No 6811201 combines online and on-site instruction. Mandatory orientation 11-12:35, Feb 14, SAC R-113. Further class meeting dates to be arranged. See Online Courses page in class schedule or go to www.sac.edu/students/online_classes for more information. N-RN 112 to be taken no sooner than within 1 year of entering the Nursing Program.)

NURSING-REGISTERED 144, CLINICAL NURSING SKILLS LABORATORY 0.5 UNITS

Supervised use of nursing skills lab to assist the student in development of psychomotor skills. Hours verified by computerized scanner. Open entry/open exit. May be repeated. Grade: CR/NCR only. Prerequisite: Enrollment in the Registered Nursing Program, EMT or any N.C.E. courses, or RN re-entry.

6814401	16 Hrs Arr		Nick J	SAC R-203	Full Semester
6814402	16 Hrs Arr		Duralde M	SJH	2/11-6/26

(ONLY Extended Campus RN 102 and 102L students can register for Tckt No 6814402)

NURSING-REGISTERED 201, NURSING PROCESS: CRITICAL BIOLOGICAL & PSYCHOSOCIAL SYSTEM NEEDS I 4 UNITS

Emphasizes nursing process of adult geriatric patients of diverse cultures with critical biological and psychosocial system needs deficits. Prerequisite: Nursing-Registered 102 & 102L, concurrent enrollment in RN 201L.

6820101	11:30-1:30pm	W	Emley C	SAC R-124	Full Semester
AND	7:00-9:10	Th	Stucken R	SAC R-128	

(ALL Registered Nursing 201 students are to contact ATI at www.atitesting.com to pay the required \$79 testing fee)

TKT#	TIME	DAYS	INSTRUCTOR	LOC./RM.	DATES
------	------	------	------------	----------	-------

NURSING-REGISTERED 201L, NURSE ACTIONS: CRITICAL BIOLOGICAL AND PSYCHOSOCIAL SYSTEM NEEDS I 5 UNITS

Emphasizes application of nursing process for adult/geriatric patients of diverse cultures with critical biological and psychosocial system need deficits. Grade: CR/NCR only. Prerequisite: Nursing-Registered 102, 102L and concurrent enrollment in Nursing-Registered 201.

6820151	240 Hrs Arr	M	Emley C	UCI	Full Semester
6820152	240 Hrs Arr	S	Stucken R	COH	Full Semester
6820153	240 Hrs Arr	M	Fray L	SJH	Full Semester
6820154	240 Hrs Arr	M	Brown S	COH	Full Semester
6820155	240 Hrs Arr	T	Fray L	SJH	Full Semester

(ALL Registered Nursing students must obtain full scheduling information from the Nursing office, SAC, R-213)

NURSING-REGISTERED 202, NURSING PROCESS: CRITICAL BIOLOGICAL AND PSYCHOSOCIAL SYSTEM NEEDS II 4 UNITS

Emphasizes nursing process for adult and geriatric patients of diverse cultures with critical psychosocial and biological system needs. Prerequisite: Nursing-Registered 201, 201L; concurrent enrollment in RN 202L.

6820201	1:00-4:00pm	M	Mixer D	SAC A-210	2/11-5/8
AND	2:00-4:50pm	Th	Haglund B	SAC A-130	
6820202	5:30-8:30pm	M	Mixer D	SAC R-307	2/11-5/8
AND	6:00-8:50pm	Th	Haglund B	SJH	

(ALL Registered Nursing 202 students are to contact ATI at www.atitesting.com to pay the required \$79 testing fee)

NURSING-REGISTERED 202L, NURSING ACTION: CRITICAL BIOLOGICAL AND PSYCHOSOCIAL SYSTEM NEEDS II 5.4 UNITS

Emphasizes application of nursing process for adult and geriatric patients of diverse cultures with critical psychosocial and biological system needs deficits. Preceptorship time and location to be arranged. Grade: CR/NCR only. Prerequisite: Nursing-Registered 201, 201L; concurrent enrollment in Nursing-Registered 202.

6820251	256 Hrs Arr	W	Brown S	SMMC	Full Semester
6820252	256 Hrs Arr	T	Mixer D	SJH	Full Semester
6820253	256 Hrs Arr	W	Steckler M	MHMC	Full Semester
6820254	256 Hrs Arr	T	Haglund B	WMC	Full Semester
6820261	256 Hrs Arr	S	Naraghi A	UCI	Full Semester
6820262	256 Hrs Arr	S	Chen G	WMC	Full Semester
6820263	256 Hrs Arr	S	Sci Staff	SJH	Full Semester

(ALL Registered Nursing students must obtain full scheduling information from the Nursing Office, SAC, R-213. All N-RN 202L students meet Feb 12 for clinical orientation at Western Medical Center, Santa Ana in Bash Auditorium, 7am-7pm. ONLY students enrolled in the Extended Campus Program may register for Tckt No's 6820261, 6820262, and 6820263.)

NUTRITION & FOOD

NUTRITION & FOOD 062, BASIC TECHNIQUES OF COOKING 2 UNITS

Basic techniques and principles of food preparation are practiced in skill applied laboratory. (Same as Catering 062.)

6906201	6:00-10:15pm	T	Marshall M	SAC T-212	Full Semester
---------	--------------	---	------------	-----------	---------------

NUTRITION & FOOD 065, CONTEMPORARY NUTRITION 3 UNITS

Nutrition fundamentals for health maintenance throughout the life cycles of diverse populations including chronic diseases, weight control and athletic performance; use of nutrient supplements and evaluation of information sources.

6906502	11:00-12:25pm	MW	Gilmore C	SAC T-212	Full Semester
6906503	6:30-9:40pm	M	Higgins R	SAC T-212	Full Semester

NUTRITION & FOOD 115, NUTRITION 3 UNITS

The function and sources of nutrients and their role in health and disease are assessed within the framework of anatomy, physiology and chemistry. The course includes utilization of scientific methods to evaluate nutrition information, research and application of current issues and controversies. Students will analyze their food intake.

6911502	11:00-12:25pm	MW	Gilmore C	SAC T-212	Full Semester
6911503	6:30-9:40pm	M	Higgins R	SAC T-212	Full Semester
6911581	Hrs Arr		Gilmore C	SAC TV	Full Semester

NUTRITION & FOOD 115H, HONORS NUTRITION 3 UNITS

An enriched, student-oriented assessment of the function and sources of nutrients and their role in health and disease within the framework of anatomy, physiology, and chemistry with application to the individual and population at large. The course includes utilization of scientific methods to evaluate nutrition information, research and application of current nutrition issues and controversies and group nutrition projects-experiments. Students will analyze their food intake. Prerequisite: A high school or college GPA of 3.0 or above.

6911504	6:30-9:40pm	M	Marshall M	SAC R-113	Full Semester
---------	-------------	---	------------	-----------	---------------

NUTRITION & FOOD 116, PRINCIPLES OF FOOD PREPARATION 3 UNITS

Basic knowledge of food science and proficiency in food preparation techniques. Emphasizes scientific basis for preparation techniques, nutritional values, safety, sanitation, and product standards. Prerequisite: Negative T.B. Test or chest X-ray.

6911601	5:00-10:20pm	T	Marshall M	SAC T-212	Full Semester
---------	--------------	---	------------	-----------	---------------

TKT#	TIME	DAYS	INSTRUCTOR	LOC./RM.	DATES
NUTRITION & FOOD 118, CULTURAL FOODS 3 UNITS					
Insight into the diverse U.S. micro cultures will be broadened through a study of their foods. Explores major cultures with an emphasis on their history, American immigration and assimilation patterns, religious dietary laws, traditional diets, special customs, etiquette practices and therapeutic uses for foods. Some examples of traditional foods will be prepared, sampled and discussed in class. Prerequisite: Negative T.B. test or chest x-ray.					
6911801	6:00-10:15pm	W	Drozdz A	SAC T-212	Full Semester
NUTRITION & FOOD 299, COOPERATIVE WORK EXPERIENCE EDUCATION 1-4 UNITS					
Supervised Nutrition/Food field experience with new tasks in major. One unit/5 hours worked/week. Limit 4 units in Nutrition & Food cooperative education classes. Must enroll in minimum of 7 units. Students must attend ONE orientation meeting. Grade: CR/NCR only. Prerequisite: 6 units of Nutrition & Food courses.					
6929902	1:35-2:40pm	T	Warner K	SAC T-201	Full Semester

OCCUPATIONAL THERAPY ASSISTANT

OCCUPATIONAL THERAPY ASSISTANT 100, MEDICAL TERMINOLOGY AND DOCUMENTATION FOR THE O.T.A. 1 UNIT					
Emphasizes basic medical terminology and documentation needed in the role of occupational therapy assistant. Prerequisite: Biology 149 or Biology 239 and 249 with concurrent enrollment in O.T.A. 101, 101L, and 111.					
7010001	8:00-8:55	W	Olah Macek S	SAC T-211	Full Semester
OCCUPATIONAL THERAPY ASSISTANT 101, FOUNDATIONS OF OCCUPATION AND OCCUPATIONAL THERAPY 4 UNITS					
Emphasizes the development of the occupational therapy profession and defines scope of practice and setting. Prerequisite: Concurrent enrollment in O.T.A. 100, 101, and 111.					
7010101	9:15-11:20	MW	Parolise M	SAC T-211	Full Semester
OCCUPATIONAL THERAPY ASSISTANT 101L, EXPLORATION OF OCCUPATION THROUGH ACTIVITY 2 UNITS					
Clinical experience exploring patterns of occupational performance, analysis of tasks and teaching/learning related to intervention. Prerequisite: English 101 or 101H, and 3 units of Speech Communication (101 or 101H, or 102 or 140 or 145 or 152). Concurrent enrollment in O.T.A. 100, 101 and 111.					
7010102	2:30-5:40pm	MW	Staff	SAC T-210	Full Semester
AND	2 Hrs Arr		Staff	SAC T-211	
OCCUPATIONAL THERAPY ASSISTANT 102, PSYCHOSOCIAL FUNCTION AND DYSFUNCTION 4 UNITS					
Emphasizes differences between psychosocial health and illness, explores strategies utilized by occupational therapists and O.T.A.'s to assist clients to achieve and maintain health. Prerequisite: O.T.A. 101 and 101L, and concurrent enrollment in O.T.A. 102L.					
7010201	Hrs Arr		Parolise M	SAC WEB	Full Semester
(Online instruction plus mandatory on-campus labs. Email instructor for more information. See Online Courses page in class schedule or go to www.sac.edu/disted for more information.)					
OCCUPATIONAL THERAPY ASSISTANT 102L, PSYCHOSOCIAL COMPONENTS OF OCCUPATION 2 UNITS					
Emphasizes O.T.A.'s role in conducting assessments and treatment protocols commonly used in pediatric, adolescent and adult psychosocial settings. Prerequisite: Occupational Therapy Assistant 100, 101, 101L, and concurrent enrollment in O.T.A. 102.					
7010251	6:00-9:10pm	MW	Parolise M	SAC T-210	Full Semester
AND	2 Hrs Arr		Parolise M	SAC T-210	
OCCUPATIONAL THERAPY ASSISTANT 103, PHYSICAL FUNCTION AND DYSFUNCTION 4 UNITS					
Emphasizes the physical components of development, the continuum of function/dysfunction of the client and the role of the O.T.A. in assessment and treatment of commonly seen physical dysfunction diagnosis. Prerequisite: Occupational Therapy Assistant 102 and 102L and concurrent enrollment in Occupational Therapy Assistant 103L and 201.					
7010301	11:15-1:20pm	TTh	Parolise M	SAC T-211	Full Semester
OCCUPATIONAL THERAPY ASSISTANT 103L, PHYSICAL COMPONENTS OF OCCUPATION 2 UNITS					
Explores the O.T.A.'s role in conducting assessments and treatments commonly used by Occupational Therapists with clients across the life span. Prerequisite: Occupational Therapy Assistant 102, and 102L and concurrent enrollment in O.T.A. 103 and 201.					
7010351	2:30-5:40pm	TTh	Hattiangadi R	SAC T-211	Full Semester
AND	2 Hrs Arr		Hattiangadi R	SAC T-211	
OCCUPATIONAL THERAPY ASSISTANT 111, APPLIED KINESIOLOGY 1 UNIT					
Emphasizes human movement and biomechanics as utilized in treatment by the O.T.A. Prerequisite: Biology 149 or 239.					
7011101	8:00-8:55	M	Parolise M	SAC T-210	Full Semester
OCCUPATIONAL THERAPY ASSISTANT 201, CONTEMPORARY MODELS OF OCCUPATIONAL THERAPY PRACTICE 4 UNITS					
This lecture/lab course explores roles of the O.T.A. in documentation and provides an overview of contemporary models for O.T. practice. Prerequisite: Occupational Therapy Assistant 102, and 102L; concurrent enrollment in O.T.A. 103 and 103L.					
7020101	8:00-11:10	TTh	Parolise M	SAC T-211	Full Semester

TKT#	TIME	DAYS	INSTRUCTOR	LOC./RM.	DATES
OCCUPATIONAL THERAPY ASSISTANT 202, LEVEL II FIELDWORK - PART I 6 UNITS					
Supervised field work experience in an occupational therapy practice setting that will provide the student opportunity to apply learned knowledge and skills. Grade: CR/NCR only. Prerequisite: Occupational Therapy Assistant 103, 103L and 201.					
7020201	40 Hrs Arr		Deponte L	SAC T-210	2/11-4/4
OCCUPATIONAL THERAPY ASSISTANT 203, LEVEL II FIELDWORK - PART II 6 UNITS					
Supervised field work experience in an occupational therapy practice setting that will provide the student opportunity to apply learned knowledge and skills. Grade: CR/NCR only. Prerequisite: Occupational Therapy Assistant 103, 103L and 201.					
7020301	40 Hrs Arr		Deponte L	SAC T-210	2/11-4/4

OFFICE TECHNOLOGY (FOR CLASSES IN COMPUTER APPLICATIONS, OFFICE TECHNOLOGIES, AND SECRETARIAL, SEE BUSINESS APPLICATIONS)

PARALEGAL

PARALEGAL 100, INTRODUCTION TO PARALEGAL STUDIES 3 UNITS					
Study of the legal assistant profession. Emphasis on duties, ethics, terminology, interviewing, investigation, court system, research, law office organization.					
5710001	8:00-11:10	TTh	Manzano F	SAC A-208	2/12-4/3
5710003	8:00-5:10pm	S	Staff	SAC A-205	2/23-3/29
5710002	7:00-10:10pm	M	Nelson A	SAC A-205	Full Semester
PARALEGAL 101, LAW OFFICE MANAGEMENT 2 UNITS					
Structure and procedures of the law office including filing systems, document management, billing and timekeeping, job search, indexing and calendaring.					
5710101	Hrs Arr		Manzano F	SAC WEB	1/8-1/31
(Orientation Tues, Jan 8, 6-7pm, SAC A-108. See Online Courses page in class schedule or go to www.sac.edu/disted for more information. Email instructor first week of class.)					
PARALEGAL 105, COOPERATIVE WORK EXPERIENCE EDUCATION - OCCUPATIONAL 1-4 UNITS					
Supervised paid or volunteer experience in student's major including new or expanded responsibilities. Must enroll in 7 units. Limit 16 units in occupational cooperative education courses. May be repeated. Grade: CR/NCR only.					
5710501	Hrs Arr		Manzano F	SAC WEB	Full Semester
(Orientation Mon, Feb 11, 6-6:50pm, SAC A108. Email instructor first week of class.)					
PARALEGAL 107, PRINCIPLES AND PROCEDURES IN THE CRIMINAL JUSTICE SYSTEM 3 UNITS					
An in-depth study of the functions and interrelationships of the several agencies of the criminal justice system. (Same as Criminal Justice 107).					
5710701	11:30-12:55pm	TTh	Manzano F	SAC A-205	Full Semester
5710702	7:00-10:10pm	T	Alexander R	SAC R-117	Full Semester
PARALEGAL 120, COMPUTERS IN THE LAW OFFICE 3 UNITS					
To educate law office personnel in basic computer concepts, The focus will be on technology currently used in the law office.					
\$4.00 material fee required for this course at registration.					
5712001	7:00-10:10pm	W	Keck E	SAC B-15	Full Semester
AND	1 Hr Arr		Roberts H	SAC A-104	
PARALEGAL 121, ETHICS FOR THE PARALEGAL 1 UNIT					
Ethics for paralegals: fees, client funds, billing, advertising, solicitation, unauthorized practice, deceit, confidentiality, conflict of interest, suppressing evidence, reporting misconduct, and professional practice obligations.					
5712102	Hrs Arr		Manzano F	SAC WEB	2/11-3/17
(Mandatory orientation Mon, Feb 11, 6-6:50pm, SAC A-108. See Online Courses page in class schedule or go to www.sac.edu/disted for more information.)					
PARALEGAL 122, ELDER LAW 2 UNITS					
Law and procedure for the aging population. Interviewing, advance directives, wills, trusts, guardianships, patients's rights in healthcare decisions, entitlement programs, managed care, long-term care insurance, viatical settlements, living facilities, financial planning, social security, and elder abuse.					
5712201	6:00-10:10pm	W	Staff	SAC A-205	4/16-6/4
PARALEGAL 130, LEGAL TRANSACTIONS 3 UNITS					
Contract law and legal document drafting. Includes contract formation, performance, breach, third party interests. Students will draft a variety of contracts and other documents.					
5713001	8:00-5:10pm	S	Staff	SAC A-205	4/19-5/24
PARALEGAL 134, PROBATE LAW & PROCEDURE 2 UNITS					
Concepts and skills required to draft probate documents and wills, and administer a probate estate.					
5713401	7:00-10:10pm	Th	Davis A	SAC A-205	2/14-4/3
PARALEGAL 135, BANKRUPTCY LAW AND PROCEDURE 2 UNITS					
Interrelated roles and responsibilities of the Paralegal and Attorney in preparation of Bankruptcy cases.					
5713501	6:00-10:10pm	Th	Staff	SAC A-205	4/16-6/4
PARALEGAL 136, REAL PROPERTY LAW AND PROCEDURE 2 UNITS					
General real property law, purchase and sales agreements, mortgages, deeds, leases, closings, and recording documents.					
5713602	8:00-11:10	TTh	Manzano F	SAC A-208	4/15-6/5

TKT#	TIME	DAYS	INSTRUCTOR	LOC./RM.	DATES
------	------	------	------------	----------	-------

PARALEGAL 137, TORT AND INSURANCE LAW 2 UNITS

Principles of tort law and defenses. Basic concepts of insurance law, preparation for trial in a tort matter.

5713701	6:00-10:10pm	W	Staff	SAC A-205	2/13-4/2
---------	--------------	---	-------	-----------	----------

PARALEGAL 143, CIVIL LITIGATION OVERVIEW 2 UNITS

Concepts and skills required for preparation of documents involved in civil litigation matters. Concepts of various discovery techniques. Overview of California civil code procedure from acceptance of case to trial, planning litigation, pleadings, motions, discovery and trial preparation.

5714301	6:00-10:10pm	T	Pollinger B	SAC A-205	2/12-4/1
---------	--------------	---	-------------	-----------	----------

PARALEGAL 144, DISCOVERY TECHNIQUES 2 UNITS

Focus on the Discovery Phase of litigation. Overview of California discovery rules, the discovery plan, preparation of discovery documents and responses. Practical applications for paralegals.

5714401	6:00-10:10pm	T	Pollinger B	SAC A-205	4/15-6/3
---------	--------------	---	-------------	-----------	----------

PARALEGAL 246, LEGAL RESEARCH AND ANALYSIS 4 UNITS

Principles of research, analysis, and techniques for the Paralegal. Must be familiar with Civil Procedure.

W 5724602	9:00-3:10pm	S	Staff	SAC A-203	2/23-6/7
5724601	7:00-10:05pm	M	Rients D	SAC A-217	Full Semester
AND	7:00-10:00pm	W	Rients D	OCLL	

PARALEGAL 248, ADVANCED RESEARCH & WRITING 3 UNITS

Advanced projects in legal research and writing. Emphasis on legal form and style. Prerequisite: Paralegal 246.

5724801	7:00-10:10pm	M	Shelley G	DMC-203	Full Semester
---------	--------------	---	-----------	---------	---------------

PARALEGAL 299, COOPERATIVE WORK EXPERIENCE EDUCATION 1-4 UNITS

Supervised work experience with new tasks in Paralegal major. 1 unit/5 hours worked per week. Limit 8 units in Paralegal work experience courses. Must enroll in minimum 7 units. Students must attend ONE orientation meeting. Grade: CR/NCR only.

5729901	Hrs Arr		Manzano F	SAC WEB	Full Semester
---------	---------	--	-----------	---------	---------------

(Orientation Mon, Feb 11, 6-6:50pm, SAC A108. Email instructor first week of class.)

PHARMACY TECHNOLOGY

PHARMACY TECHNOLOGY 048, INTRODUCTION TO PHARMACY TECHNOLOGY 2 UNITS

Introduction to the Pharmacy Technician training program. Overview of pharmacy technician practice; drug development, drug classifications; dosage forms.

7104801	9:00-11:05	T	Phi C	SAC H-210	Full Semester
7104802	6:00-8:05pm	T	Phi C	SAC H-210	Full Semester
7104803	Hrs Arr		Huynh-Dang K	SAC WEB	2/9-6/8

W AND	8:00-10:05	S	Huynh-Dang K	SAC H-201	
-------	------------	---	--------------	-----------	--

(Tckt No 7104803 combines online and in-class instruction. Class will meet on campus every other Sat starting Feb 9, 8-10:05am, SAC H-201. See Online Courses page in class schedule or go to www.sac.edu/disted for more information.)

PHARMACY TECHNOLOGY 051, BODY SYSTEMS I 3 UNITS

Study of the structure, function, diseases, and drug therapy of the musculoskeletal, respiratory, renal, and cardiovascular systems.

7105101	9:00-12:45pm	Th	Askew G	SAC H-210	Full Semester
7105103	9:00-12:45pm	F	Askew G	SAC H-210	Full Semester
7105104	6:00-9:45pm	M	Jacobson J	SAC H-201	Full Semester
7105102	6:00-9:45pm	Th	Huynh-Dang K	SAC H-210	Full Semester

PHARMACY TECHNOLOGY 054, PHARMACY CALCULATIONS 2 UNITS

Calculations related to medication preparation and distribution. Emphasis on unit-cancellation for solving pharmacy situation problems. Strong verbal component.

7105401	11:15-1:20pm	T	Phi C	SAC H-210	Full Semester
7105402	8:15-10:20pm	T	Phi C	SAC H-210	Full Semester
7105403	Hrs Arr		Huynh-Dang K	SAC WEB	2/9-6/8

W OR	10:15-12:20pm	S	Huynh-Dang K	SAC H-201	
------	---------------	---	--------------	-----------	--

(Tckt No 7105403 combines online and in-class instruction. Class will meet on campus every other Sat starting Feb 9, 10:15-12:20pm, SAC H-201. See Online Courses page in class schedule or go to www.sac.edu/disted for more information.)

PHARMACY TECHNOLOGY 056, PHARMACY OPERATIONS 4 UNITS

Hands-on training in customer service, inventory control, compounding, packaging, record-keeping, and drug distribution in the outpatient pharmacy setting. Includes prescription lab simulations. Prerequisite: Completion of Pharmacy Technology 048, 054, and 051 or 052 with grades of C or better, 30 wpm typing.

7105601	9:00-1:20pm	MW	Huynh-Dang K	SAC H-210	Full Semester
---------	-------------	----	--------------	-----------	---------------

PHARMACY TECHNOLOGY 057, INPATIENT PHARMACY SERVICES 1.5 UNITS

Technical aspects of drug distribution for the inpatient (hospital) pharmacy setting. Includes inpatient pharmacy lab simulations and computer applications. Prerequisite: Completion of Pharmacy Technology 048, 054, and 051 or 052 with grades of C or better, 30wpm typing.

7105701	9:00-1:25pm	MWF	Askew G	SAC H-210	1/7-2/1
---------	-------------	-----	---------	-----------	---------

PHARMACY TECHNOLOGY 060, STERILE PRODUCTS 4 UNITS

Aseptic technique, laminar flow theory, parenteral calculations, quality assurance procedures, and antimicrobial and antineoplastic pharmacology. Prerequisite: Pharmacy Technology 048, 054, and 051 or 052 with grades of C or better, 30 wpm typing.

7106001	5:00-10:20pm	MW	Rocha D	SAC H-210	Full Semester
---------	--------------	----	---------	-----------	---------------

TKT#	TIME	DAYS	INSTRUCTOR	LOC./RM.	DATES
------	------	------	------------	----------	-------



PHARMACY TECHNICIAN TRAINING

Santa Ana College offers an associate degree and two certificate options in Pharmacy Technology. Each option meets the requirements for licensing by the California State Board of Pharmacy. Each option also prepares students for the national Pharmacy Technician Certification Board (PTCB) exam.

Pharmacy Technology classes are offered both daytime and evening, and our schedule is designed for part-time students. Beginning students should enroll in Pharmacy Technology 048, 051, and 054.

Call the Human Services & Technology Division at 564-6800 for a complete program brochure. The brochure outlines the training options and specific courses required. The brochure also contains information on the Board of Pharmacy licensing procedure and the national PTCB certification exam. Information is also available at www.sac.edu/pharmacy

PHARMACY TECHNOLOGY 061, PHARMACY TECHNOLOGY SKILLS LAB 0.5 UNITS

Supervised use of the Pharmacy Technology lab to assist in developing technical skills for the Pharmacy Technology lab and/or Externship classes. Lab hours verified by sign-in. Open entry/open exit. May be repeated. Prerequisite: Concurrent enrollment in Pharmacy Technology 056, 057, 060, 072, or 084.

7106101	16 Hrs Arr		Rocha D	SAC H-210	Full Semester
---------	------------	--	---------	-----------	---------------

PHARMACY TECHNOLOGY 072, PHARMACY TECHNOLOGY EXTERNSHIP 0.5-4 UNITS

On-site training rotations in outpatient, inpatient, and sterile products pharmacy services. Trade-generic test required prior to placement. Sites may require additional screening. Completion of all 3 rotations (320 hours) required for the advanced certificate. Grade: CR/NCR only. Prerequisite: Pharmacy Technology 056, Pharmacy Technology 057, or Pharmacy Technology 060, with a grade of C or better; current TB clearance; Speech Communication 097 or 101.

7107201	20 Hrs Arr		Askew G	SAC H-210	1/6-6/8
---------	------------	--	---------	-----------	---------

(Mandatory meeting for all new externs: Thurs, Jan 6, 6-7pm, SAC H-210. Trade-generic equivalents test will be given.)

NEED AN UPDATE IN PHARMACY CALCULATIONS?

Pharmacy Technology 080 is an update/review course for pharmacy calculations. This course is designed for students who want to refresh their knowledge in preparation for labs or externships. If you have taken calculations in the past THREE semesters, you should NOT need to take this course! This course is NOT required for the certificate OR degree in Pharmacy Technology.

PHARMACY TECHNOLOGY 080, PHARMACY CALCULATIONS REVIEW 2 UNITS

Calculations related to medication preparation and distribution. Emphasis on unit-cancellation for solving pharmacy situation problems. Strong verbal component. May be repeated. Prerequisite: Pharmacy Technology 054.

7108001	11:15-1:20pm	T	Phi C	SAC H-210	Full Semester
7108002	8:15-10:20pm	T	Phi C	SAC H-210	Full Semester

PHARMACY TECHNOLOGY 084, STERILE PRODUCTS UPDATE 4 UNITS

Update of aseptic technique, laminar flow theory, parenteral calculations, quality assurance procedures, and antimicrobial and antineoplastic pharmacology. Prerequisite: Pharmacy Technology 060 with grade of C or better.

7108401	6:00-10:20pm	MW	Rocha D	SAC H-210	Full Semester
---------	--------------	----	---------	-----------	---------------

PHILOSOPHY

PHILOSOPHY 106, INTRODUCTION TO PHILOSOPHY (CAN PHIL 2) 3 UNITS

A survey of historical and contemporary ideas on how to live the good life.

7210601	8:00-9:25	MW	Shigematsu T	SAC D-105	Full Semester
7210602	8:00-9:25	TTh	Shigematsu T	SAC D-105	Full Semester
7210604	9:45-11:10	TTh	Shigematsu T	SAC D-105	Full Semester
7210607	11:30-12:55pm	TTh	Staff	SAC D-103	Full Semester
7210606	12:00-1:25pm	MW	Fish Z	SAC D-105	Full Semester
7210609	5:30-8:40pm	MW	Krogfoss W	SAC D-206	2/11-4/2
W 7210613	6:00-9:10pm	F	Young M	SAC D-105	4/18-6/7
AND	9:00-12:10pm	S	Young M	SAC D-105	
7210603	7:00-10:10pm	T	Redoutey M	SAC D-208	Full Semester
7210681	Hrs Arr		Snead T	SAC TV	Full Semester

PHILOSOPHY 108, ETHICS (CAN PHIL 4) 3 UNITS

Introduction to key historical and modern theories of philosophical ethics and the application of these theories to ethical issues facing society today. Assists in clarifying our thinking about morality/ethics. Course increases awareness of values in personal and contemporary issues.

7210881	Hrs Arr		Snead T	SAC TV	Full Semester
---------	---------	--	---------	--------	---------------

TKT#	TIME	DAYS	INSTRUCTOR	LOC./RM.	DATES
------	------	------	------------	----------	-------

PHILOSOPHY 110, CRITICAL THINKING**4 UNITS**

College level critical thinking and writing; philosophical reasoning and informal logic in life and composition. Prerequisite: English 101 or 101H with a grade of C or better.

7211010	7:45am-9:50	TTh	Fish Z	SAC D-207	Full Semester
7211012	8:00-12:45pm	MTWTh	Fish Z	SAC D-105	1/8-1/31
7211006	9:45-11:50	MW	Shigematsu T	SAC D-105	Full Semester
7211004	10:15-12:20pm	TTh	Young M	SAC B-5	Full Semester
7211011	6:00-10:15pm	T	Fish Z	SAC B-6	Full Semester
7211007	Hrs Arr		Fish Z	SAC WEB	Full Semester

(Tckt No 7211007 combines online and on campus instruction. Mandatory on-campus meetings: Mon: Feb 11, Mar 10, 31, Apr 28, May 19, 5-6:45pm, SAC D-105. See Online Courses page in class schedule or go to www.sac.edu/disted for more information.)

PHILOSOPHY 110H, HONORS CRITICAL THINKING**4 UNITS**

An enriched approach designed for honors students in a seminar setting. College level critical thinking and writing; philosophical reasoning and informal logic in life and composition. Prerequisite: A high school or college GPA of 3.0 or above and a grade of C or better in English 101/101H.

7211075	5:00-9:45pm	MTWTh	Fish Z	SAC D-210	1/8-1/31
---------	-------------	-------	--------	-----------	----------

PHILOSOPHY 111, INTRODUCTORY LOGIC**4 UNITS**

Formal and applied logic. Covers cognitive language, argument and proof, propositional and predicate logic, and philosophy of logic. Computer assisted instruction. (Same as Interdisciplinary Studies 111).

7211102	10:15-12:20pm	TTh	Fish Z	SAC A-206	Full Semester
---------	---------------	-----	--------	-----------	---------------

PHILOSOPHY 112, WORLD RELIGIONS**3 UNITS**

Philosophical study of the great religions: Primitive, Hinduism, Jainism, Buddhism, Taoism, Confucianism, Judaism, Christianity and Islam.

7211203	11:30-12:55pm	TTh	Shigematsu T	SAC D-105	Full Semester
7211202	7:00-10:10pm	W	Fish Z	SAC D-209	Full Semester

PHILOSOPHY 118, HISTORY OF PHILOSOPHY**3 UNITS**

An introduction to philosophy from an historical perspective: getting acquainted with the thoughts and personalities of the world's great philosophers.

7211802	12:00-1:25pm	MW	Lara R	SAC B-6	Full Semester
---------	--------------	----	--------	---------	---------------

PHILOSOPHY 144, REASONING AND PROBLEM SOLVING**3 UNITS**

Development of basic skills in critical thinking with emphasis on reasoning, problem-solving, decision-making, causation, hypothesis testing and models of thinking. (Same as Counseling 144.)

7214404	8:00-9:25	MW	Pearson C	SAC R-115	Full Semester
7214405	8:00-9:25	TTh	Pearson C	SAC R-115	Full Semester
7214450	8:00-12:15pm	TWTh	Pearson C	SAC R-115	1/8-1/31
7214406	9:30-10:55	TTh	Pearson C	SAC A-214	Full Semester
7214407	11:00-12:25pm	MW	Pearson C	SAC R-303	Full Semester
7214451	6:00-10:15pm	TWTh	Pearson C	SAC R-115	1/8-1/31

PHOTOGRAPHY

PHOTOGRAPHY 009, PHOTOGRAPHY LAB**0.5-1.5 UNITS**

Sign in/out supervised lab for working on assignments from other photo classes or on independent projects. Complete new and more advanced assignments each semester. 24 hours = 0.5 unit; 48 hours = 1 unit; 72 hours = 1.5 units. Open entry/open exit. May be repeated. Grade: CR/NCR only. Prerequisite: Concurrent enrollment in another photography course.

\$15.00 material fee required for this course at registration.

7300901	4:00-4:55pm	M	Ransome E	SAC R-303	Full Semester
---------	-------------	---	-----------	-----------	---------------

PHOTOGRAPHY 150, HISTORY OF PHOTOGRAPHY**3 UNITS**

A study of the history, aesthetics, and technical evolution of photography including an in-depth view of artistic styles and individual photographers' contributions from the 19th century to the present.

7315001	7:00-10:10pm	Th	Marquez P	SAC C-207	Full Semester
---------	--------------	----	-----------	-----------	---------------

PHOTOGRAPHY 180, BEGINNING PHOTOGRAPHY**3 UNITS**

A beginning black and white photography course including cameras, exposure meters, film, lighting, darkroom printing, and print presentation. An adjustable camera is required. May be repeated.

\$15.00 material fee required for this course at registration.

W 7318004	9:00-2:20pm	S	Lanoue M	SAC R-303	Full Semester
7318003	9:30-12:05pm	TTh	Marquez P	SAC R-303	Full Semester
7318006	12:30-3:05pm	TTh	Marquez P	SAC R-303	Full Semester
7318001	5:00-10:20pm	M	Ransome E	SAC R-303	Full Semester
7318002	5:00-10:20pm	W	Ransome E	SAC R-303	Full Semester
W 7318005	5:00-10:20pm	F	Damrel V	SAC R-303	Full Semester

PHOTOGRAPHY 181, THE ZONE SYSTEM**3 UNITS**

Emphasis on zone system techniques and interpretive assignments in black and white photography. An adjustable camera is required. Prerequisite: Photography 180.

\$15.00 material fee required for this course at registration.

7318101	5:00-10:20pm	Th	Ransome E	SAC R-303	Full Semester
---------	--------------	----	-----------	-----------	---------------

PHOTOGRAPHY 190, BEGINNING BLACK AND WHITE DIGITAL PHOTOGRAPHY**3 UNITS**

Beginning instruction in black and white digital image processing using computers to acquire images from black and white negatives and prints. Prerequisite: Photography 180.

\$15.00 material fee required for this course at registration.

W 7319001	9:00-2:20pm	S	Damrel V	SAC A-219	Full Semester
-----------	-------------	---	----------	-----------	---------------

TKT#	TIME	DAYS	INSTRUCTOR	LOC./RM.	DATES
------	------	------	------------	----------	-------

PHOTOGRAPHY 191, DIGITAL CAMERA TECHNIQUE**3 UNITS**

Instruction in electronic imaging utilizing a digital camera. Emphasis on creating digital artwork and imaging files onto paper and film using entry level skills. Digital camera not required. Prerequisite: Art 190 and Photography 180.

\$15.00 material fee required for this course at registration.

W 7319101	9:00-2:20pm	S	Damrel V	SAC A-219	Full Semester
-----------	-------------	---	----------	-----------	---------------

PHOTOGRAPHY 194, COLOR DIGITAL IMAGING**3 UNITS**

Beginning instruction in color digital image processing using computers to acquire images from color negatives, slides and prints. Prerequisite: Photography 180 and Art 190.

\$15.00 material fee required for this course at registration.

W 7319401	9:00-2:20pm	S	Damrel V	SAC A-219	Full Semester
-----------	-------------	---	----------	-----------	---------------

PHOTOGRAPHY 196, INTRODUCTION TO COMMERCIAL PHOTOGRAPHY**3 UNITS**

Instruction in commercial photography lighting, techniques and subjects. Hands-on activities, lectures, and demonstrations of portrait/wedding, architecture, table top/product illustration, stock photography, and photojournalism techniques. May be repeated. Prerequisite: Photography 180.

\$15.00 material fee required for this course at registration.

7319601	5:00-10:20pm	T	Marquez P	SAC R-303	Full Semester
---------	--------------	---	-----------	-----------	---------------

PHOTOGRAPHY 197, INTERMEDIATE COMMERCIAL PHOTOGRAPHY**3 UNITS**

Intermediate techniques in commercial photography using available and studio lighting. Further studies in the commercial subject areas of portrait/wedding, architecture, table top/product illustration, stock photography and photojournalism. May be repeated. Prerequisite: Photography 196.

\$15.00 material fee required for this course at registration.

7319701	5:00-10:20pm	T	Marquez P	SAC R-303	Full Semester
---------	--------------	---	-----------	-----------	---------------

PHOTOGRAPHY 199, INDEPENDENT STUDY**0.5-3 UNITS**

Student pursues specific project under faculty supervision. May be repeated for a maximum of 1 unit. May be repeated.

7319901	Hrs Arr		Ransome E		Full Semester
---------	---------	--	-----------	--	---------------

PHYSICAL SCIENCE

PHYSICAL SCIENCE 115, CONCEPTS IN PHYSICAL SCIENCES FOR EDUCATORS**4 UNITS**

Basic principles of physical science (chemistry and physics); concepts introduced through guided-inquiry labs and developed in discussion/lecture; content covers Physical Science requirements for multiple-subject teacher preparation programs.

7411501	9:15-11:20	MW	Jenkins C	SAC R-301	Full Semester
AND	9:15-11:20	F	Jenkins C	SAC R-309	

(This section will emphasize Physical Science for elementary school teachers)

PHYSICAL SCIENCE 117, PHYSICAL SCIENCE SURVEY**3 UNITS**

Introduction to the methods of science and concepts relating to mechanics, states of matter, waves, heat, electricity, light, atomic structure and chemical reactions. May include topics from Earth and space science. Emphasis is on basic principles, relationships, and applications to modern civilization. This course is open to all majors. Concurrent enrollment in Physical Science 118 is highly recommended.

7411701	11:00-12:25pm	MW	Raoufi A	SAC R-318	Full Semester
---------	---------------	----	----------	-----------	---------------

PHYSICAL SCIENCE 118, PHYSICAL SCIENCE SURVEY LABORATORY**1 UNIT**

Laboratory course to accompany Physical Science 117. Laboratory topics include: motion, forces, energy, thermodynamics, electricity, circuits, optics, and chemical reactions. Prerequisite: Physical Science 117 or concurrent enrollment.

7411801	1:45-4:55pm	M	Raoufi A	SAC R-328	Full Semester
---------	-------------	---	----------	-----------	---------------

PHYSICAL EDUCATION (SEE EXERCISE SCIENCE)

Physical Education is now the Division of Exercise Science. Class offerings in the areas of Adaptive Activities, Aerobic Fitness, Fitness, Health Education, Intercollegiate Activities, Off-Season Activities, the Sports Profession, and Sports Medicine can be found under the heading of Exercise Science.

PHYSICS

PHYSICS 109, SURVEY OF GENERAL PHYSICS**4 UNITS**

The study of important phenomena in physics. Topics include: mechanics, fluids, thermodynamics, sound, light, electricity, magnetism and modern physics. Recommended for all students interested in a conceptual approach to physics and students planning on taking more advanced courses in physics.

7510901	11:00-12:25pm	MW	Raoufi A	SAC R-318	Full Semester
AND	1:45-4:55pm	M	Raoufi A	SAC R-328	

PHYSICS 211, PRINCIPLES OF PHYSICS II**4 UNITS**

A calculus-based physics course designed for students majoring in the life sciences, pre-medicine, and related disciplines. Topics include: electricity and magnetism, light, optics, and modern physics. Prerequisite: Physics 210 and Mathematics 180/180H with a grade of C or better.

7521101	7:00-10:10pm	T	Abachi S	SAC R-318	Full Semester
AND	4:00-7:10pm	Th	De Santos G	SAC R-328	
7521102	7:00-10:10pm	T	Abachi S	SAC R-318	Full Semester
AND	7:15-10:25pm	Th	Abachi S	SAC R-328	

TKT#	TIME	DAYS	INSTRUCTOR	LOC./RM.	DATES
------	------	------	------------	----------	-------

**PHYSICS 217, ENGINEERING PHYSICS I (CAN PHYS 8).
(CAN PHYS SEQ B = PHYS 217+227+237)** **4 UNITS**

Principles of classical mechanics including: particle dynamics, forces, work, energy, momentum, rotational motion, equilibrium, harmonic motion and gravity. This course is designed for students majoring in physical sciences and engineering. Concurrent enrollment in Physics 217L required. Prerequisite: Mathematics 180/180H (may be taken concurrently).

7521701	11:30-12:55pm	TTh	Budarz T	SAC R-126	Full Semester
---------	---------------	-----	----------	-----------	---------------

PHYSICS 217 REQUIRES CONCURRENT ENROLLMENT IN PHYSICS 217 LAB

PHYSICS 217L, ENGINEERING PHYSICS LABORATORY **0 UNITS**

Required laboratory for Physics 217.

7521751	8:00-10:05	W	Budarz T	SAC R-328	Full Semester
AND	10:15-11:10	M	Budarz T	SAC R-328	
7521752	11:10-1:15pm	W	Budarz T	SAC R-328	Full Semester
AND	2:00-2:55pm	M	Budarz T	SAC R-318	

**PHYSICS 237, ENGINEERING PHYSICS III (CAN PHYS 14)
(CAN PHYS SEQ B = PHYS 217+227+237)** **4 UNITS**

Introduces the basic principles of fluids, wave motion, thermodynamics, sound, light, optics, and modern physics. This course is designed for students majoring in physical sciences and engineering. Concurrent enrollment in Physics 237L is required. Prerequisite: Physics 217 with a grade of C or better and Mathematics 185 (Mathematics 185 may be taken concurrently).

7523701	9:30-10:55	TTh	Budarz T	SAC R-318	Full Semester
---------	------------	-----	----------	-----------	---------------

PHYSICS 237L, ENGINEERING PHYSICS LABORATORY **0 UNITS**

Requires enrolling in Physics 237.

7523751	8:00-10:05	M	Budarz T	SAC R-328	Full Semester
AND	10:15-11:10	W	Budarz T	SAC R-328	
7523752	11:10-1:15pm	M	Budarz T	SAC R-328	Full Semester
AND	2:00-2:55pm	W	Budarz T	SAC R-328	

**PHYSICS 289, COLLEGE PHYSICS II (CAN PHYS 4)
(CAN PHYS SEQ A = PHYS 279+289)** **4 UNITS**

A trigonometry-based physics course. Topics include: light, electricity, magnetism, and modern physics. Prerequisite: Physics 279 and Mathematics 160 both with a grade of C or better.

7528901	7:00-10:10pm	T	Abachi S	SAC R-318	Full Semester
AND	4:00-7:10pm	Th	De Santos G	SAC R-328	
7528902	7:00-10:10pm	T	Abachi S	SAC R-318	Full Semester
AND	7:15-10:25pm	Th	Abachi S	SAC R-328	

**POLICE SCIENCE
(SEE CRIMINAL JUSTICE)**

POLITICAL SCIENCE

**POLITICAL SCIENCE 101, INTRODUCTION TO AMERICAN GOVERNMENTS
(CAN GOVT 2)** **3 UNITS**

A basic introductory study of the United States' national government, and California state and local governments. Satisfies graduation requirement for American institutions and state requirements for California state government.

7610101	8:00-9:25	MW	Murphy T	SAC D-106	Full Semester
7610111	8:00-9:25	MW	Andrade P	SAC D-205	Full Semester
7610102	8:00-9:25	TTh	Murphy T	SAC D-101	Full Semester
7610126	8:00-9:25	TTh	Andrade P	SAC D-204	Full Semester
7610139	8:00-11:35	MTWTh	Murphy T	SAC D-101	1/8-1/31
7610130	9:00-12:10pm	F	Uit R	SAC D-208	Full Semester
7610142	9:00-12:35pm	MTWTh	Petri M	SAC D-212	1/8-1/31
7610104	9:45-11:10	MW	Murphy T	SAC D-106	Full Semester
7610137	9:45-11:10	MW	Andrade P	SAC B-4	Full Semester
7610107	9:45-11:10	TTh	Andrade P	SAC D-101	Full Semester
7610109	11:30-12:55pm	MW	Murphy T	SAC D-101	Full Semester
7610112	11:30-12:55pm	TTh	Murphy T	SAC D-106	Full Semester
7610116	12:45-2:10pm	TTh	Andrade P	SAC D-208	Full Semester
7610118	1:00-4:10pm	TTh	Uit R	SAC D-209	4/15-6/5
7610140	1:00-4:35pm	MTWTh	Murphy T	SAC D-101	1/8-1/31
7610103	2:30-3:55pm	MW	Murphy T	SAC D-106	Full Semester
7610119	5:00-6:25pm	MW	Becker C	SAC D-101	Full Semester
7610128	6:00-9:10pm	F	Petri M	SAC D-210	4/18-6/7
AND	9:00-12:10pm	S	Petri M	SAC D-210	
7610141	6:00-9:35pm	MTWTh	Becker C	SAC D-101	1/8-1/31
7610124	7:00-10:10pm	T	Petri M	SAC B-7	Full Semester
7610125	7:00-10:10pm	W	Becker C	SAC D-106	Full Semester
7610106	7:00-10:10pm	Th	Petri M	SAC D-101	Full Semester
7610138	7:00-10:10pm	Th	Mendez E	SAC D-102	Full Semester
7610131	Hrs Arr		Mendez E	SAC WEB	Full Semester

(Tckt No 7610131 combines online and on campus instruction. Mandatory on-campus meetings: Wed: Feb 13, Jun 4, 5:30-6:30pm, SAC D-103. See Online Courses page in class schedule or go to www.sac.edu/disted for more information.)



TKT#	TIME	DAYS	INSTRUCTOR	LOC./RM.	DATES
------	------	------	------------	----------	-------

POLITICAL SCIENCE 101H, HONORS INTRODUCTION TO AMERICAN GOVERNMENTS **3 UNITS**

A student-oriented exploration of the historical and contemporary principles of American government. Study groups and individual computer-based research focus on basic political concepts of American national and state governments. Satisfies graduation requirement for American Institutions and state requirements for California state government. Prerequisite: A high school or college GPA of 3.0 or above.

7610175	7:00-10:10pm	M	Becker C	SAC D-106	Full Semester
---------	--------------	---	----------	-----------	---------------

POLITICAL SCIENCE 201, INTRODUCTION TO COMPARATIVE POLITICS **3 UNITS**

Examines the histories, political cultures and governmental arrangements of various nations and regions around the world. Major areas of focus will be the European democracies, the former and current communist countries, and the developing nations such as Mexico and India.

7620101	9:45-11:10	TTh	Murphy T	SAC D-208	Full Semester
---------	------------	-----	----------	-----------	---------------

PSYCHOLOGY

SEE ALSO INTERDISCIPLINARY STUDIES 155, HUMAN SEXUALITY

PSYCHOLOGY 100, INTRODUCTION TO PSYCHOLOGY (CAN PSY 2) **3 UNITS**

Scientific approach to understanding behavior, principles of development, learning, motivation, emotion, adjustment. One additional hour per week arranged. Automatic concurrent enrollment in Psychology N19.

7710010	8:00-9:25	TTh	Pedroza J	SAC D-434	Full Semester
W 7710019	9:00-12:10pm	S	Breeden E	SAC D-434	Full Semester
7710027	9:00-12:35pm	MTWTh	Pedroza J	SAC D-434	1/8-1/31
7710004	9:45-11:10	MW	Osborne G	SAC D-101	Full Semester
7710011	9:45-11:10	TTh	Pedroza J	SAC D-434	Full Semester
7710006	11:30-12:55pm	MW	Ortiz F	SAC D-304	Full Semester
7710008	11:30-12:55pm	MW	Pedroza J	SAC D-106	Full Semester
(Tckt No 7710008 emphasizes the Asian-American experience. Open to all students.)					
7710021	11:30-12:55pm	TTh	Pedroza J	SAC B-8	Full Semester
7710015	1:15-2:40pm	MW	Beck K	SAC D-101	Full Semester
7710013	7:00-10:10pm	T	Beck K	SAC D-434	Full Semester
7710020	7:00-10:10pm	T	Castillo R	SAC D-304	Full Semester
7710025	7:00-10:10pm	W	Castillo R	SAC D-304	Full Semester
7710012	7:00-10:10pm	Th	Castillo R	SAC D-434	Full Semester
7710081	Hrs Arr		Osborne G	SAC TV	Full Semester

PSYCHOLOGY 100

Psychology 100 classes are available in Freshman Experience and Learning Communities II. Enrollment in all classes within a block is mandatory. For additional information see page 26.

PSYCHOLOGY 100

7710002	8:00-9:25	TTh	Ortiz F	SAC D-102	Full Semester
---------	-----------	-----	---------	-----------	---------------

COUNSELING 116

2011679	12:30-1:55pm	TTh	Everett K	SAC B-29	Full Semester
---------	--------------	-----	-----------	----------	---------------

ENGLISH 101

3310110	10:00-12:05pm	TTh	Huck T	SAC D-207	Full Semester
---------	---------------	-----	--------	-----------	---------------

PSYCHOLOGY 100H, HONORS INTRODUCTION TO PSYCHOLOGY **3 UNITS**

An enriched scientific approach for honors students to understanding behavior, principles of development, learning, motivation, emotion, and adjustment. Automatic concurrent enrollment in Psychology N19. Prerequisite: A high school or college GPA of 3.0 or above.

7710031	7:00-10:10pm	T	Larson M	SAC D-212	Full Semester
---------	--------------	---	----------	-----------	---------------

PSYCHOLOGY 140, INTRODUCTION TO PSYCHOLOGY OF ADULTHOOD AND AGING **3 UNITS**

Examines psychological and related biological and social changes that occur in adulthood. Topics include health, successful aging, intimate and family relationships and mental disorders of adulthood. Designed to help students understand their own and others aging.

7714001	7:00-10:10pm	W	Osborne G	SAC D-434	Full Semester
---------	--------------	---	-----------	-----------	---------------

PSYCHOLOGY 157, INTRODUCTION TO CHILD PSYCHOLOGY **3 UNITS**

Survey of the psychological and developmental stages of children from conception through adolescence. (No credit if student has taken Human Development 107.)

7715701	9:00-12:10pm	F	Pedroza J	SAC D-434	Full Semester
---------	--------------	---	-----------	-----------	---------------

PSYCHOLOGY 200, INTRODUCTION TO BIOLOGICAL PSYCHOLOGY **3 UNITS**

An examination of the physiological basis of human behavior.

7720001	8:00-9:25	MW	Beck K	SAC D-434	Full Semester
---------	-----------	----	--------	-----------	---------------

PSYCHOLOGY 219, INTRODUCTION TO RESEARCH METHODS IN PSYCHOLOGY **3 UNITS**

Introduction to experimentation in psychology. Prerequisite: Social Science 219 or Mathematics 219 (may be taken concurrently) and Psychology 100.

7721901	11:30-12:30pm	TTh	Ortiz F	SAC D-434	Full Semester
AND	12:45-3:55pm	T	Ortiz F	SAC D-434	

PSYCHOLOGY 240, INTRODUCTION TO SOCIAL PSYCHOLOGY **3 UNITS**

The effects of society and culture on the individual and the effects of individuals on social groups. (Same as Sociology 240.) Prerequisite: Psychology 100 or Sociology 100.

7724002	9:45-11:10	MW	Ortiz F	SAC D-303	Full Semester
---------	------------	----	---------	-----------	---------------

PSYCHOLOGY 250, INTRODUCTION TO ABNORMAL PSYCHOLOGY **3 UNITS**

Introduction to the commonly diagnosed behavior pathologies, emotional, social, psychotic, organic, and developmental antecedents of abnormal behavior. Emphasis is on identification, symptomatology, etiology, and methods of therapeutic intervention. Prerequisite: Psychology 100.

7725003	9:45-11:10	MW	Pedroza J	SAC D-307-1	Full Semester
---------	------------	----	-----------	-------------	---------------

TKT#	TIME	DAYS	INSTRUCTOR	LOC./RM.	DATES
------	------	------	------------	----------	-------



On the Road to Success!!
Build your skills in Basic Math, Reading, English and ESL – on your own time!!

The Success Center
Library Building, Room L-206

We want to help you build your basic skills!
Set your own arranged hours developing the skills you need for your college classes. Sign up for IDS N04, Essential Basic Skills, 0 units, open entry/open exit.

This is YOUR center, dedicated to helping you! Come by L-206 and check it out!

READING

SOME READING CLASSES REQUIRE LAB TIME

READING N80A, FUNDAMENTALS OF READING 3 UNITS

Instruction in basic reading skills including techniques for improving vocabulary and spelling, word attack skills, and reading comprehension. Not applicable to associate degree. Grade: CR/NCR only.

8008005	8:00-9:25	MW	Colunga M	SAC D-307-1	Full Semester
8008002	8:00-9:25	TTh	Gilreath G	SAC D-307-1	Full Semester
8008017	9:45-11:10	MW	Gilreath G	SAC R-113	Full Semester
8008004	9:45-11:10	TTh	Colunga M	SAC D-307-1	Full Semester
8008015	9:45-11:10	TTh	Kossler W	SAC D-201	Full Semester
8008003	11:30-12:55pm	MW	Colunga M	SAC D-307-1	Full Semester
8008001	11:30-12:55pm	TTh	Gilreath G	SAC L-202	Full Semester
8008006	11:30-12:55pm	TTh	Houser J	SAC D-212	Full Semester
8008012	5:30-6:55pm	MW	Kossler W	SAC D-309	Full Semester
8008009	5:30-6:55pm	TTh	Houser J	SAC D-309	Full Semester
8008020	7:00-10:10pm	Th	Houser J	SAC D-309	Full Semester

READING N80B, FUNDAMENTALS OF READING 3 UNITS

Continued instruction of basic reading skills including techniques for improving vocabulary and spelling, word attack skills, and reading comprehension for students who have completed Reading N80A. Not applicable to associate degree. Grade: CR/NCR only. Prerequisite: Reading N80A.

8008008	8:00-9:25	MW	Colunga M	SAC D-307-1	Full Semester
8008022	8:00-9:25	TTh	Gilreath G	SAC D-307-1	Full Semester
8008018	9:45-11:10	MW	Gilreath G	SAC R-113	Full Semester
8008024	9:45-11:10	TTh	Colunga M	SAC D-307-1	Full Semester
8008035	9:45-11:10	TTh	Kossler W	SAC D-201	Full Semester
8008016	11:30-12:55pm	MW	Colunga M	SAC D-307-1	Full Semester
8008021	11:30-12:55pm	TTh	Gilreath G	SAC L-202	Full Semester
8008026	11:30-12:55pm	TTh	Houser J	SAC D-212	Full Semester
8008032	5:30-6:55pm	MW	Kossler W	SAC D-309	Full Semester
8008029	5:30-6:55pm	TTh	Houser J	SAC D-309	Full Semester
8008023	7:00-10:10pm	Th	Houser J	SAC D-309	Full Semester

READING N90A, INDIVIDUALIZED READING 1-3 UNITS

Individualized instruction in vocabulary, comprehension, critical evaluation and reading rate. May be continued until three units are earned. Not applicable to associate degree. Grade: CR/NCR only.

8009003	8:00-9:25	MW	Gilreath G	SAC D-309	Full Semester
8009002	8:00-9:25	TTh	Colunga M	SAC D-309	Full Semester
8009001	9:00-12:35pm	MTWTh	Kossler W	SAC D-309	1/8-1/31
8009006	9:45-11:10	MW	Kossler W	SAC D-309	Full Semester
8009008	11:30-12:55pm	MW	Gilreath G	SAC D-309	Full Semester
8009019	11:30-12:55pm	TTh	Madison M	SAC D-309	Full Semester
8009010	1:00-2:25pm	MW	Kossler W	SAC D-309	Full Semester
8009012	1:00-4:10pm	TTh	Kossler W	SAC D-309	4/15-6/5
8009015	7:00-10:10pm	T	Houser J	SAC D-309	Full Semester
8009014	7:00-10:10pm	W	Houser J	SAC D-309	Full Semester

READING N90B, INDIVIDUALIZED READING 1-3 UNITS

Further develops reading skills. Individualized instruction in vocabulary, comprehension, critical evaluation and reading rate. May be continued until three units are earned. Not applicable to associate degree. Grade: CR/NCR only. Prerequisite: Reading N90A.

8009023	8:00-9:25	MW	Gilreath G	SAC D-309	Full Semester
8009022	8:00-9:25	TTh	Colunga M	SAC D-309	Full Semester
8009021	9:00-12:35pm	MTWTh	Kossler W	SAC D-309	1/8-1/31
8009026	9:45-11:10	MW	Kossler W	SAC D-309	Full Semester
8009028	11:30-12:55pm	MW	Gilreath G	SAC D-309	Full Semester
8009020	11:30-12:55pm	TTh	Madison M	SAC D-309	Full Semester
8009030	1:00-2:25pm	MW	Kossler W	SAC D-309	Full Semester
8009032	1:00-4:10pm	TTh	Kossler W	SAC D-309	4/15-6/5
8009035	7:00-10:10pm	T	Houser J	SAC D-309	Full Semester
8009034	7:00-10:10pm	W	Houser J	SAC D-309	Full Semester

TKT#	TIME	DAYS	INSTRUCTOR	LOC./RM.	DATES
------	------	------	------------	----------	-------

READING 095, PREPARATION FOR COLLEGE READING 3 UNITS

Academic readings are critically analyzed, emphasizing comprehension, vocabulary enhancement, and study reading. Credit is earned by demonstrating comprehension at the 10th grade level. Lab may be required. Grade: CR/NCR only. Prerequisite: Satisfactory score on Reading Placement Test.

8009501	9:45-11:10	MW	Colunga M	SAC D-109	Full Semester
---------	------------	----	-----------	-----------	---------------

READING 098, READING FOR NON-NATIVE SPEAKERS OF ENGLISH 3 UNITS

Instruction in vocabulary building, word attack skills, spelling, reading strategies, and comprehending the elements of a paragraph. This class is recommended for students enrolled in ESL N40B and ESL N49.

8009801	11:30-12:55pm	TTh	Kossler W	SAC D-307	Full Semester
---------	---------------	-----	-----------	-----------	---------------

READING 100A, ADVANCED & CRITICAL READING 1-3 UNITS

Students earning 2 or 3 units will attend additional hours. Emphasis on critical analysis and rapid reading. Grade: CR/NCR only. Prerequisite: Qualifying score on Reading Placement Test or completion of Reading N90A or N90B with a grade of C or better.

8010002	8:00-9:25	MW	Gilreath G	SAC D-309	Full Semester
8010001	8:00-9:25	TTh	Colunga M	SAC D-309	Full Semester
8010003	9:00-12:35pm	MTWTh	Kossler W	SAC D-309	1/8-1/31
8010004	9:45-11:10	MW	Kossler W	SAC D-309	Full Semester
8010006	11:30-12:55pm	MW	Gilreath G	SAC D-309	Full Semester
8010019	11:30-12:55pm	TTh	Madison M	SAC D-309	Full Semester
8010008	1:00-2:25pm	MW	Kossler W	SAC D-309	Full Semester
8010010	1:00-4:10pm	TTh	Kossler W	SAC D-309	4/15-6/5
8010013	7:00-10:10pm	T	Houser J	SAC D-309	Full Semester
8010012	7:00-10:10pm	W	Houser J	SAC D-309	Full Semester

READING 100B, ADVANCED & CRITICAL READING 1-3 UNITS

Further develops skills in critical analysis and rapid reading. Students earning 2 or 3 units will attend additional lab hours. Course may be continued to 3 units. Grade: CR/NCR only. Prerequisite: Reading 100A.

8010022	8:00-9:25	MW	Gilreath G	SAC D-309	Full Semester
8010021	8:00-9:25	TTh	Colunga M	SAC D-309	Full Semester
8010031	9:00-12:35pm	MTWTh	Kossler W	SAC D-309	1/8-1/31
8010024	9:45-11:10	MW	Kossler W	SAC D-309	Full Semester
8010026	11:30-12:55pm	MW	Gilreath G	SAC D-309	Full Semester
8010018	11:30-12:55pm	TTh	Madison M	SAC D-309	Full Semester
8010028	1:00-2:25pm	MW	Kossler W	SAC D-309	Full Semester
8010030	1:00-4:10pm	TTh	Kossler W	SAC D-309	4/15-6/5
8010033	7:00-10:10pm	T	Houser J	SAC D-309	Full Semester
8010032	7:00-10:10pm	W	Houser J	SAC D-309	Full Semester

**RETAILING
(SEE MARKETING)**

SCIENCE

SCIENCE 200, ENVIRONMENT OF MAN 3 UNITS

Study of current problems such as energy, food, resources, population, and land use, including economic and political factors. A natural science elective. (Same as Biology 200 and Environmental Studies 200.)

8220001	7:00-10:10pm	T	Chlup I	SAC R-228	Full Semester
---------	--------------	---	---------	-----------	---------------

SIGN LANGUAGE

SIGN LANGUAGE 110, BEGINNING COMMUNICATION WITH THE DEAF 3 UNITS

An introductory course designed to teach the Manual Alphabet and basic American Sign Language of about 500 words.

8661001	9:30-10:50	MW	Yingst S	SAC R-117	Full Semester
8661002	9:30-10:50	TTh	Yingst S	SAC R-117	Full Semester
8661009	6:30-9:40pm	W	Ascheman J	SAC B-29	Full Semester
8661003	7:00-10:05pm	M	Yu L	SAC B-29	Full Semester
8661004	7:00-10:05pm	Th	Yu L	SAC B-31	Full Semester

SIGN LANGUAGE 111B, INTERMEDIATE COMMUNICATION WITH THE DEAF 3 UNITS

Development of American Sign Language skills and beginning interpreting voice to sign. Prerequisite: Sign Language 110.

8661102	11:00-12:25pm	TTh	Yingst S	SAC R-117	Full Semester
---------	---------------	-----	----------	-----------	---------------

SIGN LANGUAGE PROGRAM

Enroll in the Sign Language Education Program and help meet the growing demand for qualified sign language interpreters. The program offers opportunities for students to earn a certificate and for K-12 classroom interpreters/aides to upgrade their signing skills with formal training.

See the Sign Language Education option under Communications in the RSCCD Catalog for additional information on certificate requirements.

For more information, contact Monica Collins at (714) 564-6283.

TKT#	TIME	DAYS	INSTRUCTOR	LOC./RM.	DATES
SIGN LANGUAGE 116, PERSPECTIVES ON DEAFNESS 3 UNITS					
Audiological, educational, social and communicative aspects of the deaf and hearing impaired. A look at historical perspectives and current trends, philosophies, ideologies, and deaf community as a subculture.					
8661601	7:00-10:10pm	M	Ascherman J	SAC B-11	Full Semester

SECRETARIAL
(SEE BUSINESS APPLICATIONS)

SEWING
(SEE FASHION DESIGN MERCHANDISING)

SOCIAL SCIENCE

SOCIAL SCIENCE 219, STATISTICS AND PROBABILITY **4 UNITS**

Beginning course in statistics. Includes use of computer software. (Same as Mathematics 219.) Prerequisite: Mathematics 080 or 140 with a grade of C or better or equivalent skills as measured by the Math Level 3 Exam and a course equivalent to Mathematics 080 or 140.

W 8321911	7:00am-9:30	MW	Ortiz F	SAC H-108	Full Semester
8321960	8:00-1:20pm	S	Rivera F	SAC H-108	Full Semester
8321950	8:30-1:15pm	MTWThF	Anthony M	SAC H-108	1/7-2/1
8321901	9:45-12:15pm	TTh	McClure C	SAC H-108	Full Semester
8321902	12:15-2:45pm	MW	Zarske J	SAC H-108	Full Semester
8321908	12:30-3:00pm	TTh	Anthony M	SAC H-108	Full Semester
8321914	2:45-5:15pm	MW	Klaus R	SAC H-108	Full Semester
8321903	5:30-8:00pm	MW	Pham T	SAC H-108	Full Semester
8321904	7:45-10:15pm	TTh	Nguyen D	SAC H-108	Full Semester

SOCIAL SCIENCE 219H, HONORS STATISTICS AND PROBABILITY **4 UNITS**

Enriched format for the beginning course in statistics, using a seminar approach and computers and individual research and presentations, with applications designed around individual interests of the students. (Same as Mathematics 219H.) Prerequisite: Mathematics 080 or 140 and a high school or college GPA of 3.0 or above.

8321975	1:00-3:30pm	MW	McClure C	SAC A-213	Full Semester
---------	-------------	----	-----------	-----------	---------------

SOCIOLOGY

SEE ALSO INTERDISCIPLINARY STUDIES 155, HUMAN SEXUALITY

SOCIOLOGY 100, INTRODUCTION TO SOCIOLOGY (CAN SOC 2) **3 UNITS**

The study of human societies and behavior focusing on the processes of social interaction, patterns of social inequality, and the influence of social institutions on individuals as members of social groups. Includes an understanding of factors promoting social stability and leading to social change.

8410010	8:00-9:25	MW	Dobos D	SAC D-304	Full Semester
8410007	9:00-12:10pm	F	Staff	SAC D-103	Full Semester
8410004	9:45-11:10	MW	Staff	SAC D-201	Full Semester
8410011	9:45-11:10	MW	Dobos D	SAC D-304	Full Semester
8410008	11:30-12:55pm	TTh	Larsen S	SAC D-304	Full Semester
W 8410003	6:00-9:10pm	F	Seifert R	SAC D-105	2/15-4/5
AND	9:00-12:10pm	S	Seifert R	SAC D-105	
8410006	6:00-9:35pm	MTWTh	Larsen S	SAC D-213	1/8-1/31
8410002	7:00-10:10pm	W	Seifert R	SAC D-107	Full Semester
8410014	7:00-10:10pm	W	Dobos D	SAC D-208	Full Semester
8410005	7:00-10:10pm	Th	Seifert R	SAC B-4	Full Semester
8410012	Hrs Arr		Dobos D	SAC WEB	Full Semester

(Tckt No 8410012 combines online and on-campus instruction. Mandatory on-campus meetings: Wed: Feb 13, Mar 5, Apr 2, May 7, Jun 4, 5-6pm, SAC D-401. See Online Courses page in class schedule or go to www.sac.edu/students/disted for more information.)

8410007	Hrs Arr		Dobos D	SAC WEB	1/8-1/31
(Go to www.sac.edu/students/disted for more information.)					
Email instructor first wrkk of class.)					

8410081	Hrs Arr		Rogers N	SAC TV	1/8-1/31
8410082	Hrs Arr		Rogers N	SAC TV	Full Semester

SOCIOLOGY 112, RELATIONSHIPS, MARRIAGES, AND FAMILY DYNAMICS **3 UNITS**

An introduction to the process of positive relationship formation which can lead to committed relationships. A diversity of issues including dating, mate selection, marriage, communications, sexuality, parenting, separation, divorce, working families, violence and abuse, family importance, remarriages, stepchildren, and the later years are covered.

8411204	Hrs Arr		Dobos D	SAC WEB	Full Semester
(See Online Courses page in class schedule or go to www.sac.edu/disted for more information)					
8411205	Hrs Arr		Dobos D	SAC WEB	Full Semester
(See Online Courses page in class schedule or go to www.sac.edu/disted for more information)					
8411207	Hrs Arr		Dobos D	SAC WEB	1/8-1-31
(See Online Courses page in class schedule or go to www.sac.edu/disted for more information)					
8411201	11:30-12:55pm	MW	Larsen S	SAC D-211	Full Semester
8411281	Hrs Arr		Rogers N	SAC TV	Full Semester
8411282	Hrs Arr		Rogers N	SAC TV	1/8-1/31

TKT#	TIME	DAYS	INSTRUCTOR	LOC./RM.	DATES
SOCIOLOGY 140, ANALYSIS OF SOCIAL TRENDS & PROBLEMS (CAN SOC 4) 3 UNITS					
An analysis of the direction of recent social trends and the causes and proposed solutions to contemporary social problems.					
8414001	9:45-11:10	TTh	Dobos D	SAC D-304	Full Semester

SOLAR
(SEE ENVIRONMENTAL STUDIES)

SPANISH

SPANISH LANGUAGE CLASSES REQUIRE LAB TIME OF ONE HOUR PER WEEK

SPANISH N51, SPANISH FOR PUBLIC PERSONNEL **3 UNITS**

Basic conversation and vocabulary needed by police, firemen, health professionals, school employees and others. Not applicable to associate degree.

8505102	7:00-10:10pm	M	Chaparro L	SAC B-8	Full Semester
---------	--------------	---	------------	---------	---------------

SPANISH 101, ELEMENTARY SPANISH I (CAN SPAN 2) (CAN SPAN SEQ A = SPAN 101+102) **5 UNITS**

Practice and integration of pronunciation, grammar, vocabulary, common idioms, listening, speaking, reading and writing techniques for oral and written communication. Introduction of Hispanic culture. NOTE: Some sections designated for SPANISH SPEAKERS. Spanish 101 is equivalent to two years of high school Spanish.

8510103	8:00-10:30	MW	Lopez-Jaurequi L	SAC D-305	Full Semester
(Tckt No 8510103 is designated for Spanish speakers. Open to all students.)					
8510118	8:00-12:30pm	MTWThF	Guerrero M	SAC D-305	1/8-2/1
(Tckt No 8510118 is designed for Spanish speakers. Open to all students.)					
8510114	9:45-12:15pm	TTh	Robins T	SAC D-102	Full Semester
8510113	11:00-1:30pm	MW	Lopez-Jaurequi L	SAC D-305	Full Semester
(Tckt No 8510113 is designated for Spanish speakers. Open to all students.)					
8510105	11:00-1:30pm	TTh	Chaparro L	SAC D-305	Full Semester
8510107	1:45-4:15pm	MW	Staff	SAC D-305	Full Semester
8510115	4:15-6:45pm	MW	Staff	SAC D-305	Full Semester
8510111	4:15-6:45pm	TTh	Staff	SAC D-302	Full Semester
8510101	7:00-9:30pm	MW	Staff	SAC D-303	Full Semester
8510109	7:00-9:30pm	MW	Molina Cesareo L	SAC D-305	Full Semester
(Tckt No 8510109 is designated for Spanish speakers. Open to all students.)					

8510112	7:00-9:30pm	TTh	Espinosa A	SAC D-109	Full Semester
8510181	Hrs Arr		Lopez-Jaurequi L	SAC TV	Full Semester
(Tckt No 8510181 combines a TV course with classroom instruction. Students must attend all the following on-campus meetings: Mon: Feb 11, Mar 10, Apr 1, May 5, Jun 2, 4:30-6:50pm, SAC D-304.)					

Foreign Language Laboratories are located in SAC D-301 at Santa Ana College and SCC E-304 at Santiago Canyon College. The labs are open during morning and evening hours for the use of transfer level students. These students are automatically enrolled in Spanish 009 Language Lab for hours exceeding the course requirement.

SPANISH 102, ELEMENTARY SPANISH II **5 UNITS**

A college level Spanish class focusing on dictation, vocabulary and grammar; reading, conversation and composition for the expression of ideas. NOTE: Some sections designated for SPANISH SPEAKERS. Spanish 102 is equivalent to the third year of high school Spanish. Prerequisite: Spanish 101 or two years of high school Spanish with a grade of C or better.

8510207	Hrs Arr		Guerrero M	SAC WEB	Full Semester
(Tckt No 8510207 combines online and on campus instruction. Mandatory on-campus meetings: Fri, Feb 15, Mar 14, Apr 4, May 9, May 30, 9:30am-12pm, SAC D-305. See Online Line Courses page in class schedule or go to www.sac.edu/disted for more information.)					
8510206	8:00-10:30	MW	Labrit G	SAC D-208	Full Semester
8510203	8:00-10:30	TTh	Lopez-Jaurequi L	SAC D-305	Full Semester
(Tckt No 8510203 is designed for Spanish speakers. Open to all students. Content of interest to Future Spanish teachers.)					
8510202	4:15-6:45pm	MW	Staff	SAC D-303	Full Semester
8510281	Hrs Arr		Guerrero M	SAC TV	Full Semester
(Tckt No 8510281 combines a TV course with classroom instruction. Student must attend the following on-campus meetings: Wed, Feb 13, Mar 12, Apr 3, May 7, Jun 4, 4:30-6:50pm, SAC D-304.)					

SPANISH 102H, HONORS ELEMENTARY SPANISH II **5 UNITS**

Further enhanced and intensive practice and integration of dictation, grammar, vocabulary, common idioms, reading, conversation and composition for communication. Note: Some sections are designated for Spanish speakers. Spanish 102H is equivalent to the third year of high school Spanish. Prerequisite: Spanish 101/101H, or two years of high school Spanish and a high school or college GPA of 3.0 or above.

8510275	12:00-2:30pm	TTh	Guerrero M	SAC D-206	Full Semester
---------	--------------	-----	------------	-----------	---------------

SPANISH 195A, ADVANCED CONVERSATIONAL SPANISH **3 UNITS**

Further development of conversational skills, language structures, vocabulary and idiomatic expressions through discussions or reading selections dealing with historical and current events to deepen appreciation of Hispanic cultures. Laboratory work may be required. Prerequisite: Spanish 102 or 102H.

8519501	8:00-9:25	TTh	Guerrero M	SAC D-303	Full Semester
---------	-----------	-----	------------	-----------	---------------

TKT#	TIME	DAYS	INSTRUCTOR	LOC./RM.	DATES
------	------	------	------------	----------	-------



ATENCIÓN

SPANISH SECTIONS FOR THE SPANISH SPEAKING

Spanish 101 (Ticket Numbers 8510103, 8510113, 8510118 and 8510109) and **Spanish 102** (Ticket Number 8510203) are designed for Spanish speaking students. Emphasis is placed on culture, reading and writing.

New Spanish TV Courses: These courses combine a telecourse with classroom instruction. Only 5 on-campus meetings are required: **Spanish 101** (Ticket Number 8510181) and **Spanish 102** (Ticket Number 8510281).

TKT#	TIME	DAYS	INSTRUCTOR	LOC./RM.	DATES
------	------	------	------------	----------	-------

SPECIAL SERVICES N63, ADVANCES IN LEARNING POTENTIAL			0.2-1.8 UNITS		
Instruction to improve learning efficiency by monitoring academic progress, organizational and learning strategies, and providing specialized tutoring. Student must have a verifiable disability. Not applicable to associate degree. Open entry/open exit. May be repeated. Grade: CR/NCR only.					
8606301	Hrs Arr		Kobane M	SAC U-103	Full Semester
8606302	Hrs Arr		Choo B	SAC U-103	Full Semester
8606303	Hrs Arr		Choo B	SAC U-103	1/8-2/1
SPECIAL SERVICES 072B, LEARNING STRATEGIES			2 UNITS		
Designed to teach students additional strategies, study skills, and other compensatory techniques necessary for them to realize their full academic potential. (Same as Study Skills 072B.) May be repeated.					
8607201	10:00-12:05pm	W	Kobane M	SAC A-216	Full Semester
SPECIAL SERVICES N83, CAREER EXPLORATION			0.5 UNITS		
Designed to assist disabled students explore appropriate career areas. Open to disabled students in the Workability Program. Not applicable to associate degree. Open entry/open exit. May be repeated. Grade: CR/NCR only.					
8608301	8 Hrs Arr		Morris-Pfyl S	SAC L-225	Full Semester
SPECIAL SERVICES N84, EMPLOYMENT PREPARATION			0.5-3 UNITS		
A comprehensive course designed to prepare students for the transition between school and employment. Includes identifying appropriate job/career goals, assessing personal strengths, developing skills to obtain employment such as resume writing and interviewing, and utilizing SCAN competencies for employment retention and advancement. Arranged schedule. Open entry/open exit. Grade: CR/NCR only.					
8608401	Hrs Arr		Waller L	SAC L-225	Full Semester
SPECIAL SERVICES N91, COMPUTER ASSISTED COGNITIVE LEARNING			0.5-2 UNITS		
Computer assisted instruction to increase learning potential of students with attention, memory, problem solving and other cognitive difficulties. Designed for students with acquired brain impairments. Arranged schedule. Open entry/open exit. May be repeated. Grade: CR/NCR only.					
8609199	1 Hr Arr		Miller R	SAC M-105	Full Semester
8609101	Hrs Arr		Miller R	SAC M-105	1/8-1/31
SPECIAL SERVICES N92, ASSISTIVE COMPUTER TECHNOLOGY INSTRUCTION			0.5-2 UNITS		
This course is intended for students with disabilities. Emphasis is on mastering appropriate assistive computer technologies and to provide instruction in Windows, Microsoft Office and Internet/E-mail access. Not applicable to associate degree. Open entry/open exit. May be repeated. Grade: CR/NCR only.					
8609299	4 Hrs Arr		Dutton D	SAC U-103	Full Semester
SPECIAL SERVICES N98, TRANSITION TO COLLEGE			1 UNIT		
Designed to facilitate the transition of students with disabilities from high school to college regarding campus services, policies and procedures, and the strategies necessary for college success. May be repeated. Grade: CR/NCR only.					
8609801	Hrs Arr		Siegel G	SAC WEB	Full Semester
(Online instruction plus mandatory meetings on high school campus: Feb 5, Mar 5, Apr 2, May 7, 28, (time TBA). See Online Courses page in class schedule or go to www.sac.edu/distd for more information. Email instructor first week of class.)					
SPECIAL SERVICES 118, INTRODUCTION TO SPEECH-LANGUAGE PATHOLOGY ASSISTING			1 UNIT		
Overview of the field of speech-language pathology, professional standards and scope of responsibilities of the speech-language pathologist and speech-language pathology assistant in health care and educational settings. (Same as Speech Communication 118.)					
8611801	6:00-6:55pm	T	Porter M	SAC B-19	Full Semester
SPECIAL SERVICES 120, SPEECH-LANGUAGE PATHOLOGY CLINICAL MANAGEMENT AND PROCEDURES			2 UNITS		
Organizational and functional skills required in the speech-language pathology workplace. Includes data collection, record keeping, safety issues and computer applications. (Same as Speech Communication 120.)					
8612001	7:00-9:10pm	T	Porter M	SAC B-28	Full Semester
SPECIAL SERVICES 150, OBSERVATION OF SPEECH-LANGUAGE PATHOLOGY CLINICAL PRACTICES			1 UNIT		
Beginning clinical observation of practices and procedures required in speech-language pathology. Observation sites will be both educational and medical. (Same as Speech Communication 150.)					
8615002	Hrs Arr	T	Porter M	SAC B-18	Full Semester
(Mandatory orientation meeting Tues, Feb 12, 5-5:55pm)					
SPECIAL SERVICES 160, INTRODUCTION TO COMMUNICATIVE DISORDERS AND TREATMENT			3 UNITS		
A study of communicative disorders in children and adults. The role of the speech-language pathologist and audiologist in educational, medical and other professional settings. (Same as Speech Communication 160.)					
8616001	6:00-9:10pm	M	Greenhalgh P	SAC B-21	Full Semester
SPECIAL SERVICES 180, SPEECH-LANGUAGE PATHOLOGY SCREENING PROCESSES AND INTERVENTION PROCEDURES			3 UNITS		
Screening processes and intervention procedures used for children and adults with speech, language, and hearing disorders. Equipment and procedures utilized in therapeutic treatment. (Same as Speech Communication 180.) Prerequisite: Special Services 160.					
8618001	6:00-9:10pm	Th	Greenhalgh P	SAC B-6	Full Semester

SPANISH 195B, ADVANCED CONVERSATIONAL SPANISH			3 UNITS		
Further practice with language structures, new vocabulary and idioms. Discussions and class presentations based on literary and current event readings to deepen appreciation of Hispanic cultures. Laboratory work may be required. Prerequisite: Spanish 195A.					
8519521	8:00-9:25	TTh	Guerrero M	SAC D-303	Full Semester
SPANISH 201, INTERMEDIATE SPANISH I			5 UNITS		
A college level Spanish class focusing on conversation, composition; expansive review of usage and grammar. Discussions of history and culture through interpretive readings. Prerequisite: Spanish 102 or 102H or three years of high school Spanish with a grade of C or better.					
8520148	7:00-7:50	MTWThF	Espinosa M	VHS	1/7-2/8
SPANISH 202, INTERMEDIATE SPANISH II			5 UNITS		
A college level Spanish class focusing on conversation, composition, and specialized review of usage and grammar. Discussions of history and culture through literature. Prerequisite: Spanish 201 or 201H or four years of high school Spanish with a grade of C or better.					
8520203	7:00am-7:50	MTWThF	Espinosa M	VHS	2/11-6/6
8520202	11:00-1:30pm	MW	Guerrero M	SAC B-8	Full Semester

SPECIAL SERVICES

SEE ALSO STUDY SKILLS

SPECIAL SERVICES N45, INTRODUCTION TO SERVICE LEARNING			2 UNITS		
Opportunities for students to do volunteer work in the community. Includes structured time and activities for students to evaluate their community services experiences. Not applicable to associate degree. May be repeated. Grade: CR/NCR only.					
8604501	4:00-6:00pm	Th	Aguayo A	SAC R-117	Full Semester
SPECIAL SERVICES N50A, ENGLISH FOR THE DEAF AND HARD OF HEARING			0.5-3 UNITS		
Language function and composition for the student with hearing loss. Includes improvement of basic written English language skills. Student must submit proof of audiological verifiable hearing loss. Not applicable to associate degree. Open entry/open exit. May be repeated.					
8605001	11:00-12:20pm	MW	Staff	SAC B-30	Full Semester
8605002	12:30-1:55pm	MW	Staff	SAC B-30	Full Semester
SPECIAL SERVICES N50B, ENGLISH FOR THE DEAF AND HARD OF HEARING			0.5-3 UNITS		
Mechanics of the English language and composition for the deaf or hard of hearing student. The focus is on continuing improvement of English comprehension and writing skills. Student must submit proof of audiological verifiable hearing loss. Not applicable to associate degree. Open entry/open exit. May be repeated.					
8605021	11:00-12:20pm	MW	Staff	SAC B-30	Full Semester
8605022	12:30-1:55pm	MW	Staff	SAC B-30	Full Semester
SPECIAL SERVICES N51, SPEECH AND LANGUAGE DEVELOPMENT			0.5-1 UNIT		
Individualized or small group instruction for speech/language/hearing disabilities. Emphasis on communication disabilities of pronunciation, stuttering, aphasia, voice and hearing. Arranged schedule. (Same as Speech Communication N51.) Open entry/open exit. May be repeated. Grade: CR/NCR only.					
8605101	3 Hrs Arr		Miller R	SAC M-105	Full Semester
SPECIAL SERVICES N57, ACQUIRED BRAIN IMPAIRMENT LANGUAGE RECOVERY			0.5-1 UNIT		
Individualized/group instruction for students with cognitive/language problems from stroke or head trauma. See instructor to arrange schedule. Not applicable to associate degree. (Same as Speech Communication N57). Open entry/open exit. May be repeated. Grade: CR/NCR only.					
8605701	Hrs Arr		Winkle K	SAC M-105	Full Semester
8605702	Hrs Arr		Miller R	SAC M-105	1/8-2/1
SPECIAL SERVICES N62, ASSESSMENT OF LEARNING POTENTIAL			0.2 UNITS		
Designed to determine eligibility for learning disabilities services through an assessment of learning potential and basic skill levels. Not applicable to associate degree. Open entry/open exit. May be repeated.					
8606201	Hrs Arr		Choo B	SAC U-103	1/8-2/1
8606204	Hrs Arr		Kobane M	SAC U-103	Full Semester
8606205	Hrs Arr		Choo B	SAC U-103	Full Semester

TKT#	TIME	DAYS	INSTRUCTOR	LOC./RM.	DATES
------	------	------	------------	----------	-------

Connect with people and make a difference . . . Santa Ana College's

SPEECH-LANGUAGE PATHOLOGY ASSISTANT PROGRAM (SLPA)

A NEW PROGRAM IN A HELPING PROFESSION

Explore this rewarding, fulfilling career.
SLP Assistants will be trained to help children and adults improve their communication skills.
Contact the SLPA for more information, 714/564-6668.

SPECIAL SERVICES 190, SPEECH-LANGUAGE PATHOLOGY ASSISTANT CLINICAL FIELDWORK 2 UNITS

Application of clinical practice procedures in an educational setting under appropriate supervision. (Same as Speech Communication 190.) Prerequisite: Special Services 120, 150, 160; concurrent enrollment in Special Services 180.
8619001 6:00-6:50pm W Porter M SAC B-20 Full Semester

SPECIAL SERVICES 200, ADULT AND GERIATRIC COMMUNICATION DISORDERS 3 UNITS

Speech, language, and hearing disorders experienced by the adult and geriatric populations. Assessment tools and treatment strategies used to treat acquired disorders such as adult aphasia, dysarthria, and hearing loss. (Same as Speech Communication 200.)
8620001 7:00-10:10pm Th Rosenthal J SAC B-25 Full Semester

SPECIAL SERVICES 205, EXCEPTIONALITY AND SPECIAL NEEDS IN HUMAN DEVELOPMENT 3 UNITS

Diseases and disorders commonly found in children and young adults which result in exceptionality. Emphasis on identifying and learning ways to meet the child's special needs. (Same as Human Development 205.)
8620501 11:00-12:25pm MW Creager C SAC B-33 Full Semester

SPECIAL SERVICES 250, SPEECH-LANGUAGE PATHOLOGY ASSISTANT CLINICAL FIELDWORK II 2 UNITS

Application of advanced clinical procedures in a clinical or medical setting under appropriate supervision. (Same as Speech Communication 250.) Prerequisite: Special Services 180, 190.
8625001 6:00-6:50pm W Porter M SAC B-20 Full Semester
(Mandatory orientation meeting Wed, Feb 13, 5-5:55pm, SAC B-26)

SPEECH COMMUNICATION

NON-NATIVE ENGLISH SPEAKERS - IMPROVE YOUR SKILLS

We offer a pronunciation lab where you can practice your speaking and listening skills. You can enroll any time during the semester in Speech Communication N50. For information and lab hours, contact Marilou Morris SAC C-216, Santa Ana College, or phone (714) 564-5635.

SPEECH COMMUNICATION N50, PRONUNCIATION SKILLS LABORATORY 0.5-1 UNIT

Sign-in/out listen/speak practice in a lab setting. Utilizes pronunciation and vocabulary/conversational material. 24 hours earns 0.5 unit, 48 hours, 1 unit. Not applicable to associate degree. Open entry/open exit. May be repeated. Grade: CR/NCR only.
8705001 Hrs Arr Morris M SAC D-301 Full Semester

SPEECH COMMUNICATION N51, SPEECH AND LANGUAGE DEVELOPMENT 0.5-1 UNIT

Individualized or small group instruction for speech/language/hearing disabilities. Emphasis on communication disabilities of pronunciation, stuttering, aphasia, voice and hearing. (Same as Special Services N51.) Open entry/open exit. May be repeated. Grade: CR/NCR only.
8705101 Hrs Arr Winkle K SAC M-105 Full Semester

All Speech N52, N53, and N59 classes require one hour arranged outside of class weekly

SPEECH COMMUNICATION N52A, BEGINNING AMERICAN ENGLISH PRONUNCIATION SKILLS 3 UNITS

Instruction in the pronunciation and recognition of American English speech sounds and sound spelling patterns. Lab hours are required. Not applicable to Associate Degree. May be repeated. Grade: CR/NCR only. Prerequisite: English for Multilingual Students 055.
8705203 8:00-9:25 TTh Huebsch M SAC R-303 Full Semester
8705202 9:00-12:10pm F Winkle K SAC P-114 Full Semester
8705204 9:30-10:55 MW Huebsch M SAC P-114 Full Semester
8705205 12:30-3:40pm TTh Winkle K SAC D-211 4/15-6/5
8705208 7:00-10:10pm T Mantong K SAC B-9 Full Semester

SPEECH COMMUNICATION N52B, INTERMEDIATE AMERICAN ENGLISH PRONUNCIATION SKILLS 3 UNITS

More extensive instruction in American English speech sounds. Emphasis on more difficult sounds, sound blends, word endings, syllable and word stress. Not applicable to associate degree. May be repeated. Grade: CR/NCR only. Prerequisite: Speech Communication N52A.
8705222 8:00-9:25 MW Huebsch M SAC P-114 Full Semester
8705201 9:00-1:15pm S Burns R SAC C-213 Full Semester

TKT#	TIME	DAYS	INSTRUCTOR	LOC./RM.	DATES
------	------	------	------------	----------	-------

SPEECH COMMUNICATION N53, ADVANCED AMERICAN ENGLISH PRONUNCIATION SKILLS 3 UNITS

For those who have learned the American English sound system. Intensive practice pronouncing English words, sentences with appropriate stress and intonation, and difficult sounds/sound patterns in conversations. Not applicable to associate degree. May be repeated. Prerequisite: EMLS 107 and Speech Communication N52B.
8705303 7:00-10:10pm W Thornton J SAC C-207 Full Semester

SPEECH COMMUNICATION N54, ACCENT REDUCTION 0.5-1 UNIT

Individualized instruction to assist in the reduction of foreign accents. Improvement of discrimination and production of the American English sound system, melody, intonation and stress patterns. Not applicable to associate degree. Open entry/open exit. May be repeated. Grade: CR/NCR only. Prerequisite: English for Multilingual Students 055.
8705401 Hrs Arr Winkle K SAC M-105 Full Semester

SPEECH COMMUNICATION N57, ACQUIRED BRAIN IMPAIRMENT LANGUAGE RECOVERY 0.5-1 UNIT

Individualized/group instruction for student with cognitive/language problems from stroke or head trauma. See instructor to arrange schedule: Not applicable to associate degree. (Same as Special Services N57). Open entry/open exit. May be repeated. Grade: CR/NCR only.
8705701 Hrs Arr Miller R SAC M-105 Full Semester

SPEECH COMMUNICATION N59, PRONUNCIATION REVIEW 1 UNIT

Review of the pronunciation system of American English. Includes identification of specific student needs in pronunciation improvement. Designed for non-native speakers who have completed a class in pronunciation skills. May be repeated. Grade: CR/NCR only. Prerequisite: Speech Communication N52A.
8705901 10:00-12:25pm MW Trueman J SAC D-214 1/7-1/30
8705902 11:00-11:55 Th Morris M SAC C-202 Full Semester
AND 1 Hr Arr Speech Staff

All Speech 097 classes require one hour arranged outside of class weekly

SPEECH COMMUNICATION 097, AMERICAN ENGLISH CONVERSATIONAL SKILLS 3 UNITS

Designed for non-native speakers. Intensive oral practice emphasizing communication in social, academic and business situations. Laboratory hours are required. Preparation for Speech Communication 101. May be repeated. Prerequisite: Speech Communication N53 or concurrent enrollment; English for Multilingual Students 107 or higher.
8709701 11:30-12:55pm MW Huebsch M SAC C-202 Full Semester
8709710 7:00-10:10pm M Watkins M SAC B-30 Full Semester

SPEECH COMMUNICATION 098, INTRODUCTION TO ACADEMIC SPEAKING SKILLS 3 UNITS

Beginning course for students with some previous instruction in English. Listening discrimination, pronunciation, speaking and listening skill building are integrated in controlled and independent speaking and listening activities. Skills are intensively practiced and reviewed. May be repeated. Grade: CR/NCR only.
8709802 11:30-12:55pm TTh Huebsch M SAC A-217 Full Semester

SPEECH COMMUNICATION 101, INTRODUCTION TO INTERPERSONAL COMMUNICATION (CAN SPCH 8) 3 UNITS

Introduction to communication theory, listening, perception, language usage, non-verbal communication and conflict management. Recommended for students who have completed or are currently enrolled in English 101.
8710130 6:30am-7:55 MW Lockwood L SAC C-214 Full Semester
8710102 8:00-9:25 MW Lockwood L SAC C-214 Full Semester
8710136 8:00-9:25 MW Wagner H SAC C-202 Full Semester
8710105 8:00-9:25 TTh Morris M SAC C-202 Full Semester
8710129 8:00-9:25 TTh Hondo K SAC C-213 Full Semester
8710189 8:30-1:00pm MTTh Morris M SAC C-202 1/7-1/31
8710107 9:00-12:10pm F Harris M SAC C-213 Full Semester
8710140 9:00-12:10pm S Harris M SAC C-214 Full Semester
8710109 9:30-10:55 MW Wagner H SAC C-202 Full Semester
8710115 9:30-10:55 TTh Morris M SAC C-202 Full Semester
8710103 11:00-12:25pm MW Hondo K SAC P-114 Full Semester
8710118 11:00-12:25pm MW Moorhead C SAC C-214 Full Semester
8710104 11:00-12:25pm TTh Fondren S SAC P-114 Full Semester
8710117 12:30-1:55pm MW Hondo K SAC P-114 Full Semester
8710112 2:00-5:10pm Th Lockwood L SAC C-214 Full Semester
8710127 3:45-6:55pm M Holder V SAC C-213 Full Semester
8710106 6:00-10:15pm TWTh Brown H SAC P-114 1/8-2/2
8710133 6:15-9:25pm F Habel L SAC C-214 Full Semester
8710170 6:30-9:50pm MW McPherson D SAC D-206 4/14-6/4
8710108 7:00-10:10pm M Holder V SAC C-202 Full Semester
8710135 7:00-10:10pm T Brown H SAC C-214 Full Semester
8710101 7:00-10:10pm Th McPherson D SAC D-214 Full Semester
8710179 Hrs Arr Strong K SAC WEB Full Semester

(Tckt No 8710179 combines online and on campus instruction. Mandatory on-campus meetings Mon & Wed: Feb. 11, Mar 31, Apr 2, May 19, May 21, May 28, 2-3:20pm, SAC C-202. See Online page in class schedule or go to www.sac.edu/disted for more information.)

TKT#	TIME	DAYS	INSTRUCTOR	LOC./RM.	DATES
SPEECH 101					
Speech 101 classes are available in Freshman Experience and Learning Communities II. Enrollment in all classes within a block is mandatory. For additional information see page 26.					
SPEECH 101					
8710122	9:30-10:55	TTh	Fondren S	SAC P-114	Full Semester
COUNSELING 111					
2011108	8:30-9:25	T	Robledo R	SAC P-114	Full Semester

SPEECH COMMUNICATION 101H, HONORS INTRODUCTION TO INTERPERSONAL COMMUNICATION					
3 UNITS					
An enriched approach designed for honors students. Seminar mode. Stresses the development of analytical thinking, writing, and speaking skills. Theory, listening, perception, language, nonverbal communication, conflict management. Completion of or concurrent enrollment in English 101 recommended. Prerequisite: A high school or college GPA of 3.0 or above.					
8710199	3:00-6:10pm	W	Fondren S	SAC C-214	Full Semester

SPEECH COMMUNICATION 102, PUBLIC SPEAKING					
3 UNITS					
Teaches critical thinking skills in relation to public speaking. Emphasis on the process, principles and major facets of critical thinking with practice through oral presentations. Speech Communication 097 recommended for non-native speakers.					
8710213	8:00-9:25	MW	Brown L	SAC C-213	Full Semester
8710208	8:00-9:25	TTh	Brown L	SAC C-214	Full Semester
8710214	8:00-9:25	TTh	Langlois K	SAC C-207	Full Semester
8710228	8:00-12:15pm	F	Johnson J	SAC C-202	3/14-6/6
8710289	8:30-1:00pm	MTTh	Hondo K	SAC P-114	1/7-1/31
8710202	9:30-10:55	MW	Brown L	SAC C-213	Full Semester
8710201	9:30-10:55	TTh	Hondo K	SAC C-213	Full Semester
8710225	9:30-10:55	TTh	Brown L	SAC C-214	Full Semester
8710222	11:00-12:25pm	MW	Brown L	SAC C-213	Full Semester
8710211	11:00-12:25pm	TTh	Hondo K	SAC C-213	Full Semester
8710204	12:30-3:40pm	MW	Moorhead C	SAC D-205	4/14-6/4
8710224	12:30-3:45pm	MW	Morris M	SAC C-213	2/11-4/2
8710229	2:00-5:10pm	T	Lockwood L	SAC C-214	Full Semester
8710226	3:00-6:10pm	F	Habel L	SAC C-214	Full Semester
8710203	6:00-10:15pm	TTh	Fondren S	SAC D-201	1/8-1/31
AND	9:00-1:15pm	S	Fondren S	SAC D-201	
8710205	6:00-10:15pm	F	Holder V	SAC P-114	2/22-3/29
AND	9:00-1:15pm	S	Holder V	SAC P-114	
8710215	7:00-10:10pm	M	MacAbeo L	SAC C-213	Full Semester
8710209	7:00-10:10pm	T	Holder V	SAC P-114	Full Semester
8710207	7:00-10:10pm	Th	Dinger M	SAC C-202	Full Semester

SPEECH COMMUNICATION 103, INTRODUCTION TO INTERCULTURAL COMMUNICATION					
3 UNITS					
Introduction to communication patterns of various cultural groups, with emphasis on skills and techniques necessary for effective intercultural, crosscultural, and interracial communication. Stresses the development of analytical thinking, speaking, and writing skills. Speech Communication 097 recommended for non-native speakers.					
8710301	Hrs Arr		Strong K	SAC WEB	Full Semester
(Tckt No 8710301 combines online and on campus instruction. Mandatory on-campus meetings Mon & Wed, Feb. 11, Mar 31, Apr 2, May 19, 21, 28, 3:30-4:50pm, SAC C-202. See Online page in class schedule or go to www.sac.edu/disted for more information.)					
8710305	7:00-10:10pm	W	Holder V	SAC C-202	Full Semester

SPEECH COMMUNICATION 118, INTRODUCTION TO SPEECH-LANGUAGE PATHOLOGY ASSISTING					
1 UNIT					
Overview of the field of speech-language pathology, professional standards, and scope of responsibilities of the speech-language pathologist and speech-language pathology assistant in health care and educational settings. (Same as Special Services 118.)					
8711801	6:00-6:55pm	T	Porter M	SAC B-19	Full Semester

SPEECH COMMUNICATION 120, SPEECH-LANGUAGE PATHOLOGY CLINICAL MANAGEMENT AND PROCEDURES					
2 UNITS					
Organizational and functional skills required in the speech-language pathology workplace. Includes data collection, record keeping, safety issues and computer applications. (Same as Special Services 120.)					
8712001	7:00-9:10pm	T	Porter M	SAC B-28	Full Semester

SPEECH COMMUNICATION 140, ARGUMENTATION AND DEBATE					
3 UNITS					
Principles of debate techniques with emphasis on methods of logical analysis and reflective thinking. Completion of or concurrent enrollment in Speech Communication 097 recommended for non-native speakers.					
8714007	9:30-10:55	MW	Lockwood L	SAC C-214	Full Semester
8714002	11:00-12:25pm	TTh	McPherson D	SAC C-207	Full Semester
8714003	12:30-1:55pm	T	Lockwood L	SAC C-214	Full Semester
8714001	7:00-10:10pm	W	Brown H	SAC C-214	Full Semester

SPEECH COMMUNICATION 145, GROUP DYNAMICS					
3 UNITS					
Principles and methods of communication as applied in the small group setting. Processes of group dynamics and cooperative problem solving. Speech Communication 097 recommended for non-native speakers.					
8714502	9:30-10:55	TTh	Langlois K	SAC D-204	Full Semester
8714501	7:00-10:10pm	W	Fondren S	SAC P-114	Full Semester

TKT#	TIME	DAYS	INSTRUCTOR	LOC./RM.	DATES
SPEECH COMMUNICATION 150, OBSERVATION OF SPEECH-LANGUAGE PATHOLOGY CLINICAL PRACTICES					
1 UNIT					
Beginning clinical observation of practices and procedures required in speech-language pathology. Observation sites will be both educational and medical. (Same as Special Services 150.)					
8715001	5:00-5:50pm	T	Porter M	SAC B-18	Full Semester
(Mandatory orientation meeting Tues, Feb 12, 5-5:55pm)					

SPEECH COMMUNICATION 151, VOICE AND DICTION FOR EFFECTIVE COMMUNICATION					
3 UNITS					
Study of basic speech and voice production; training in pronunciation, projection and related vocal skills for effective communication. Designed for individuals with special demands on vocal production in their vocation. Speech Communication 097 recommended for non-native speakers. May be repeated.					
8715101	7:00-10:10pm	T	Rosenthal J	SAC D-213	Full Semester

SPEECH COMMUNICATION 160, INTRODUCTION TO COMMUNICATIVE DISORDERS AND TREATMENT					
3 UNITS					
A study of communicative disorders in children and adults. The role of the speech-language pathologist and audiologist in educational, medical and other professional settings. (Same as Special Services 160.)					
8716002	6:00-9:10pm	M	Greenhalgh P	SAC B-21	Full Semester

SPEECH COMMUNICATION 170, INTRODUCTION TO PHONETICS					
3 UNITS					
Topics include the International Phonetic Alphabet, methods of describing and categorizing speech sounds, American English sound system, and transcription of speech samples. Discussion of sound systems of other languages. Speech Communication N53 recommended for non-native speakers.					
8717001	5:00-8:10pm	T	Morris M	SAC C-207	Full Semester

SPEECH COMMUNICATION 180, SPEECH-LANGUAGE PATHOLOGY SCREENING PROCESSES AND INTERVENTION					
3 UNITS					
Screening processes and intervention procedures used for children and adults with speech, language and hearing disorders. Equipment and procedures utilized in therapeutic treatment. (Same as Special Services 180.) Prerequisite: Speech Communication 160.					
8718001	6:00-9:10pm	Th	Greenhalgh P	SAC B-6	Full Semester

SPEECH COMMUNICATION 190, SPEECH-LANGUAGE PATHOLOGY ASSISTANT CLINICAL FIELDWORK I					
2 UNITS					
Application of clinical practice procedures in an educational setting under appropriate supervision. (Same as Special Services 190.) Prerequisite: Speech Communication 120, 150, 160, 180.					
8719001	6:00-6:50pm	W	Porter M	SAC B-20	Full Semester

SPEECH COMMUNICATION 200, ADULT AND GERIATRIC COMMUNICATION DISORDERS					
3 UNITS					
Speech, language, and hearing disorders experienced by the adult and geriatric populations. Assessment tools and treatment strategies used to treat acquired disorders such as adult aphasia, dysarthria, and hearing loss. (Same as Special Services 200.)					
8720001	7:00-10:10pm	Th	Rosenthal J	SAC B-25	Full Semester

SPEECH COMMUNICATION 250, SPEECH-LANGUAGE PATHOLOGY ASSISTANT CLINICAL FIELDWORK II					
2 UNITS					
Application of advanced clinical practice procedures in a clinical or medical setting under appropriate supervision. (Same as Special Services 250.) Prerequisite: Speech Communication 180, 190.					
8725002	6:00-6:50pm	W	Porter M	SAC B-20	Full Semester

**SPEECH LANGUAGE PATHOLOGY ASSISTANT
(SEE SPECIAL SERVICES & SPEECH COMMUNICATION)**

**STUDENT SERVICES
(SEE SPECIAL SERVICES & STUDY SKILLS)**

STUDY SKILLS

STUDY SKILLS 072B, LEARNING STRATEGIES					
2 UNITS					
Designed to teach students additional strategies, study skills, and other compensatory techniques necessary for them to realize their full academic potential. (Same as Special Services 072B.) May be repeated.					
8807201	10:00-12:05pm	W	Kobane M	SAC A-216	Full Semester

STUDY SKILLS 091, EFFECTIVE STUDY TECHNIQUES					
1 UNIT					
Designed to help students improve the following study skills: time management, textbook study, lecture notetaking, test taking, exam preparation. May be repeated. Grade: CR/NCR only.					
8809104	8:00-8:55	F	Coffman J	SAC B-6	Full Semester
8809105	9:30-10:25	F	Coffman J	SAC B-6	Full Semester
8809106	11:00-11:55	F	Coffman J	SAC B-6	Full Semester
8809101	12:00-1:50pm	F	Nguyen M	SAC B-11	4/18-6/6
8809103	12:30-2:20pm	Th	Std Svc staff	SAC B-11	4/24-6/5

STUDY SKILLS N96, TRAINING FOR TUTORIAL ASSISTANTS					
0.5 UNITS					
Designed to help develop those skills necessary to become an effective tutor. Not applicable to associate degree. Open entry/open exit. Grade: CR/NCR only.					
8809601	8 Hrs Arr		Conner M	SAC U-103	Full Semester
8809602	8 Hrs Arr		Choo B	SAC U-103	Full Semester
(Tckt No 8809602 is designed for tutoring students with Learning Disabilities. Open to all students.)					
Designed for instructional assistants working with students with learning disabilities.					

TKT#	TIME	DAYS	INSTRUCTOR	LOC./RM.	DATES
------	------	------	------------	----------	-------

TUTORIAL LEARNING CENTER

The SAC Tutorial Learning Center offers FREE tutoring to students taking courses through RSCCD. The Center, located in U-103, provides a variety of tutorial programs and services to help students maximize their learning potential. Tutoring takes place in both one-to-one and small group settings; exam reviews are offered on occasion for some subjects. You can schedule a tutoring appointment by calling (714) 564-6260, or by visiting U-103. Investigate the TLC today to see how it can benefit you!

STUDY SKILLS 109, COLLEGE LEARNING SKILLS

3 UNITS

Development of operative college learning skills. Topics include: Time Management, Listening, Notetaking, Textbook Study, Exam Preparation, Memory Techniques, and Critical Reading. May be repeated.

8810905	9:30-10:55	TTh	Sanchez G	SAC B-30	Full Semester
8810902	11:00-12:25pm	TTh	Sanchez G	SAC B-30	Full Semester
8810906	1:00-4:10pm	T	Sanchez G	SAC L-202	Full Semester
8810903	6:00-9:10pm	M	Staff	SAC B-22	Full Semester
8810907	Hrs Arr		Norwood J	SAC WEB	Full Semester

(Students must attend one of the following on-campus orientations: Tues, Jan 30, 1:30-2:30pm, or Jan 31, 5:30-6:30pm, or Mon, Feb, 11, 1-2pm, or 6-7pm, or Tues, Feb 12, 1-2pm, or 6-7pm, SAC L-225. See Online Courses page in class schedule or go to www.sac.edu/disted for more information.)

SUPERVISION (SEE MANAGEMENT)

SURVEYING (SEE ENGINEERING)

TELECOMMUNICATIONS (SEE JOURNALISM & TV/VIDEO COMMUNICATIONS)

TELEVISION/VIDEO COMMUNICATIONS

TELEVISION/VIDEO COMMUNICATIONS LAB 009

Orientation meetings for all students enrolled in the Telev/Video 009 Lab will be held during the second week of the semester to discuss arranged hours and regular meeting times for crew members. Watch the department bulletin boards in DMC-135 or call 241-5774. You must attend one of the meetings during that second week to remain enrolled.

TELEVISION/VIDEO COMMUNICATIONS 009, TELEVISION/VIDEO COMMUNICATIONS LABORATORY

0.5-3 UNITS

Sign-in/out supervised work on projects/production assigned in TV/Video classes 110 or above or independent projects. 24 hrs/0.5 unit, 48 hrs/1 unit, 96 hrs/2 units, 144 hrs/3 units. Open entry/open exit. May be repeated. Grade: CR/NCR only. Prerequisite: Concurrent enrollment in another Television/Video Communications production course 110 or above.

9000901	9 Hrs Arr		Schultz R	DMC-135	Full Semester
---------	-----------	--	-----------	---------	---------------

TELEVISION/VIDEO COMMUNICATIONS 100, INTRODUCTION TO ELECTRONIC MEDIA: TV, RADIO, FILM, AND THE INTERNET

3 UNITS

Survey of historical development, impact, and business practices of TV, Radio, Film, and the Internet. Emphasizes career opportunities and basic studio operations.

9010001	11:00-12:25pm	MW	Bales T	SAC A-210	Full Semester
---------	---------------	----	---------	-----------	---------------

TELEVISION/VIDEO COMMUNICATIONS 104, HISTORY OF FILM FROM 1945 TO PRESENT

3 UNITS

A lecture/visual aids course exploring film as an art form and developing appreciation of historical, artistic and technical advances. (Same as Theatre Arts 104.)

9010402	1:00-4:10pm	W	Bales T	SAC A-210	Full Semester
9010499	6:00-10:15pm	TWTh	Bales T	SAC A-210	1/8-1/31



TV News

Auditions and orientation for SAC-TV's cable newscasts "Around & About OC" and "Noticiero Latino" will be held Tuesday, February 12 at 11 a.m. at the new Digital Media Center, 1300 S. Bristol Room DMC-135, Santa Ana. Sign up for TV/Video 130 to be involved or call (714) 241-5778.

TKT#	TIME	DAYS	INSTRUCTOR	LOC./RM.	DATES
------	------	------	------------	----------	-------

TELEVISION/VIDEO COMMUNICATIONS 105, MASS MEDIA & SOCIETY:

This class now fulfills the General Education (GETC Plan C-Area 4 Social & Behavioral Sciences requirements for transfer to the California State Universities system and the Humanities General Education requirement for Plan A-Area C for the A.A. Degree.

For further information regarding Television/Video Communications classes, please call the Department at 241-5778.

TELEVISION/VIDEO COMMUNICATIONS 105, MASS MEDIA & SOCIETY (CAN JOUR 4)

3 UNITS

Exploration of the history, effects, and role of mass media in U.S. society. Examines major media forms (TV, radio, film, newspapers, magazines, ads, the Internet) in our information-conscious culture.

9010501	9:30-10:55	MW	Bales T	SAC A-210	Full Semester
---------	------------	----	---------	-----------	---------------

IMPORTANT INFORMATION FOR TV/VIDEO PRODUCTION CLASS STUDENTS:

Materials such as videotape, blank DVD disks, and alkaline batteries used in creating individual class projects MUST BE PURCHASED BY THE STUDENT. Students needing to check equipment out of the SAC-TV facility for use in the field MUST MAINTAIN A REFUNDABLE EQUIPMENT DEPOSIT ON ACCOUNT. Please consult with your instructor for specific information regarding your class and about buying materials or establishing a refundable equipment deposit.

TELEVISION/VIDEO COMMUNICATIONS 105H, HONORS MASS MEDIA & SOCIETY

3 UNITS

Enriched honors course of intensive exploration of historical impact and current influence of Mass Media (newspapers, TV, Internet, etc.). Uses critical thinking skills in seminar-setting to assess media's role in society. Prerequisite: A high school or college GPA of 3.0 or above.

9010531	9:30-10:55	MW	Bales T	SAC A-210	Full Semester
---------	------------	----	---------	-----------	---------------

TELEVISION/VIDEO COMMUNICATIONS 110, INTRODUCTION TO TELEVISION PRODUCTION

3 UNITS

Introduction to production of television programs and operation of studio and field equipment. Includes overview of production theory, terminology and procedures, as well as hands-on training in use of cameras, audio, lighting, and control room apparatus. Prior or concurrent enrollment in TV/Video Communications 100 recommended.

9011001	9:00-10:55	TTh	Schultz R	DMC-135	Full Semester
AND	2 Hrs Arr		Schultz R	DMC-135	

TELEVISION/VIDEO COMMUNICATIONS 112, INTRODUCTION TO VIDEO EDITING & POSTPRODUCTION

3 UNITS

Fundamental methods and techniques used to edit video for TV, film, web and multi-media. Hands-on training in basic operation of Final Cut Pro digital non-linear editing system and software. Completion of Television/Video 110 or concurrent enrollment recommended.

9011201	7:00-10:10pm	M	Schultz R	DMC-204	Full Semester
AND	3 Hrs Arr		Schultz R	DMC-204	

TELEVISION/VIDEO COMMUNICATIONS 114, ADVANCED VIDEO POSTPRODUCTION

3 UNITS

Advanced editing theory and techniques for television, film, web and multi-media. Hands-on training in the use of Avid digital nonlinear video editing and special effects systems. Prerequisite: Television/Video Communications 112 with a grade of C or better.

9011401	7:00-10:10pm	M	Coleman J	DMC-204	Full Semester
AND	3 Hrs Arr		Coleman J	DMC-204	

TELEVISION/VIDEO COMMUNICATIONS 115A, SINGLE-CAMERA PRODUCTION AND EDITING

3 UNITS

Fundamental approaches and techniques utilized in single-camera production for television, film, web and multi-media. Hands-on training in operation of portable analog and digital video and audio production equipment, as well as lighting. Prior or concurrent enrollment in Television/Video Communications 110 and 112 recommended. May be repeated.

9011501	7:00-10:10pm	W	Schultz R	DMC-135	Full Semester
AND	3 Hrs Arr		Schultz R	DMC-135	

TELEVISION/VIDEO COMMUNICATIONS 115B, ADVANCED SINGLE-CAMERA PRODUCTION AND EDITING

3 UNITS

Continued development of knowledge and skills in single-camera production technology and practices. Emphasis on professional production standards and technical advancements in digital and High Definition TV. Individual assignments vary in subsequent semesters. Prior or concurrent enrollment in Television/Video Communications 110 and 112 recommended. May be repeated. Prerequisite: Television/Video Communications 115A with grade of C or better.

9011502	7:00-10:10pm	W	Schultz R	DMC-135	Full Semester
AND	3 Hrs Arr		Schultz R	DMC-135	

TELEVISION/VIDEO COMMUNICATIONS 130, PRINCIPLES OF BROADCAST NEWS

3 UNITS

Introduction to broadcast journalism emphasizing the preparation of media newscasts. (Same as Journalism 130.) Prior or concurrent enrollment in Television/Video Communications 110 recommended.

9013001	11:00-1:30pm	TTh	Bales T	DMC-135	Full Semester
---------	--------------	-----	---------	---------	---------------

TELEVISION/VIDEO COMMUNICATIONS 161, FUNDAMENTALS OF AUDIO FOR TV & FILM

1.5 UNITS

Introduction to the technical aspects of audio systems used for television production in both studio and field. Provides overview of sound characteristics and requirements. Emphasizes of audio control and recording devices. Prior or concurrent enrollment in Television/Video Communications 110 recommended.

9016101	7:00-10:10pm	Th	Coleman J	DMC-135	2/14-4/3
---------	--------------	----	-----------	---------	----------

TKT#	TIME	DAYS	INSTRUCTOR	LOC./RM.	DATES
TELEVISION/VIDEO COMMUNICATIONS 165, DVD AUTHORIZING 3 UNITS					
Introduction to DVD technology and authoring process. Learn to operate digital video workstation and create professional DVD presentations that contain interactive menus. Prior or concurrent enrollment in either Television/Communications 110 and 112 is recommended.					
9016501	7:00-10:10pm	T	Roehrig J	DMC-204	Full Semester
AND	3 Hrs Arr		Roehrig J	DMC-204	
TELEVISION/VIDEO COMMUNICATIONS 181, MODELING FUNDAMENTALS 2.5 UNITS					
Skill development in 2D spline drawing, 3D modeling techniques, and scene construction using Autodesk 3D Studio Max. Project work and other assignments created in lab. (Same as Art 196A.) May be repeated. Prerequisite: Art 195.					
9018101	6:00-10:15pm	T	Waterman P	SAC A-223	2/11-3/31
AND	5 Hrs Arr		Waterman P	SAC A-223	
TELEVISION/VIDEO COMMUNICATIONS 182, 3D ADVANCED MODELING TECHNIQUES 2.5 UNITS					
Computer graphics image development with emphasis on advanced modeling techniques, refined surface materials, and environmental lighting techniques using 3D Studio Max. (Same as Art 196B.) May be repeated. Prerequisite: Art 196A or Television/Video Communications 181.					
\$15.00 material fee required for this course at registration.					
9018201	6:00-10:15pm	T	Waterman P	SAC A-223	4/14-6/2
AND	5 Hrs Arr		Waterman P	SAC A-223	
TELEVISION/VIDEO COMMUNICATIONS 185, 3D ANIMATION FUNDAMENTALS 2.5 UNITS					
Introduction to computer animation using 3D motion techniques. Tutorials and projects combine to develop animation skills using 3D Studio Max. (Same as Art 197A.) May be repeated. Prerequisite: Art 196AB or Television/Video Communications 181, 182.					
9018501	6:00-10:15pm	Th	Waterman P	SAC A-217	2/13-4/2
AND	5 Hrs Arr		Waterman P	SAC A-217	
TELEVISION/VIDEO COMMUNICATIONS 186, 3D ANIMATION INTERMEDIATE TECHNIQUES 2.5 UNITS					
Continued study of computer animation techniques using 3D Studio Max. Animation projects developed through team approach with small groups of individuals. (Same as Art 197B.) May be repeated. Prerequisite: Art 197A or Television/Video Communications 185.					
9018601	6:00-10:15pm	Th	Waterman P	SAC A-217	4/16-6/4
AND	6 Hrs Arr		Waterman P	SAC A-217	
TELEVISION/VIDEO COMMUNICATIONS 198, INTRODUCTION TO PROTOOLS 1.5 UNITS					
Fundamental features and applications of ProTools audio software used in post-production for television, film and music. Orientation to functions, user interface and actual operation of digital audio workstation. Techniques and aesthetics associated with creation of well-mixed soundtracks are addressed. Hands-on practice with digital recording and editing of soundtracks. (Same as Music 198.)					
9019801	6:00-9:30pm	TWTh	Graham A	DMC-204	1/8-1/31
TELEVISION/VIDEO COMMUNICATIONS 230A, BROADCAST NEWS PRODUCTION 4 UNITS					
Writing, editing, and production of a live weekly newscast. (Same as Journalism 230A.) Prior or concurrent enrollment in Television/Video Communications 110 recommended. Prerequisite: Television/Video Communications 130.					
9023001	11:00-1:30pm	TTh	Bales T	DMC-135	Full Semester
AND	4 Hrs Arr		Bales T	DMC-135	
TELEVISION/VIDEO COMMUNICATIONS 230B, BROADCAST NEWS PRODUCTION 4 UNITS					
Writing, editing, and production of a live weekly newscast. (Same as Journalism 230B.) Prerequisite: Television/Video Communications 230A.					
9023021	11:00-1:30pm	TTh	Bales T	DMC-135	Full Semester
AND	4 Hrs Arr		Bales T	DMC-135	
TELEVISION/VIDEO COMMUNICATIONS 230C, BROADCAST NEWS PRODUCTION 4 UNITS					
Writing, editing and production of a live weekly newscast. (Same as Journalism 230C.) Prerequisite: Television/Video Communications 230B.					
9023041	11:00-1:30pm	TTh	Bales T	DMC-135	Full Semester
AND	4 Hrs Arr		Bales T	DMC-135	
TELEVISION/VIDEO COMMUNICATIONS 230D, BROADCAST NEWS PRODUCTION 4 UNITS					
Writing, editing and production of a live weekly newscast. (Same as Journalism 230D.) Prerequisite: Television/Video Communications 230C.					
9023061	11:00-1:30pm	TTh	Bales T	DMC-135	Full Semester
AND	4 Hrs Arr		Bales T	DMC-135	
TELEVISION/VIDEO COMMUNICATIONS 260, LIGHTING SYSTEMS AND TECHNIQUES FOR TV/VIDEO 1.5 UNITS					
Study of television lighting systems and techniques used in studio and location production environments. Includes hands-on training and overview of instruments, light control and electrical power requirements. Prior or concurrent enrollment in Television/Video Communications 110 recommended.					
9026001	7:00-10:10pm	Th	Weiner J	DMC-135	4/17-6/5
AND	3 Hrs Arr		Tv Staff	DMC-135	
TELEVISION/VIDEO COMMUNICATIONS 298, TV/VIDEO COMMUNICATIONS PRACTICUM/INTERNSHIP 2-4 UNITS					
Supervised field work/internship at selected professional locations. 10-20 hours weekly practical experience in various positions. Concurrent enrollment or completion of one TV/Video Communications production class recommended. Open entry/open exit. May be repeated. Grade: CR/NCR only.					
9029899	11:00-12:25pm	MW	Bales T	SAC A-210	Full Semester
AND	20 Hrs Arr		Bales T		
9029825	7:00-10:10pm	W	Schultz R	DMC-135	Full Semester
AND	20 Hrs Arr		Schultz R	DMC-135	

TKT#	TIME	DAYS	INSTRUCTOR	LOC./RM.	DATES
DMC as a room indicator in this schedule refers to the new Digital Media Center located at 1300 S. Bristol Street, Santa Ana, California.					
THEATRE ARTS					
THEATRE ARTS 100, INTRODUCTION TO THEATRE 3 UNITS					
An introduction to the art and concepts of theatre through a study of modern and historical theories of dramatic structure, playwrighting, directing, design, and acting. Attendance at live theatre required.					
9110001	9:30-10:55	MW	De Mita J	SAC P-105	Full Semester
9110099	Hrs Arr		Tivenan V	SAC WEB	Full Semester
(See Online Courses page in class schedule or go to www.sac.edu/disted for more information. Email instructor first week of class.)					

THEATRE ARTS 100, INTRODUCTION TO THEATRE

Fulfills the Art General Education requirement for the California State Universities (C). Also, Theatre Arts 100 fulfills the Humanities General Education requirement for the A.A. Degree (C1).

For further information regarding Theatre Arts classes, please phone the Theatre Dept. 564-5666.

THEATRE ARTS 104, HISTORY OF FILM FROM 1945 TO PRESENT 3 UNITS					
A lecture/visual aids course exploring film as an art form and developing appreciation of historical, artistic and technical advances. (Same as Television/Video Communications 104.)					
9110402	1:00-4:10pm	W	Bales T	SAC A-210	Full Semester
9110499	6:00-10:15pm	TWTh	Bales T	SAC A-210	1/8-1/31

THEATRE ARTS 110, ACTING FUNDAMENTALS (CAN DRAM 8) 3 UNITS					
Study of acting involving development of acting techniques, styles and disciplines. Provides theory and practical experience with varied characterizations. Emphasizes individual growth and acquired skills necessary to the acting craft.					
9111001	11:00-1:05pm	MW	De Mita J	SAC P-105	Full Semester

THEATRE ARTS 118, FUNDAMENTALS OF SCENE STUDY 2 UNITS					
A continued study for the beginning actor in the preparation and presentation of scenes from contemporary drama. Students prepare scenes with partners for performance and critique. Recommended for acting majors. May be repeated. Prerequisite: Theatre Arts 110.					
9111811	11:00-1:05pm	MW	De Mita J	SAC P-105	Full Semester

THEATRE ARTS 135, TECHNICAL PRODUCTION 1 UNIT					
Supervised practical application and instruction in stage production techniques. Each repetition presents more advanced material. May be repeated.					
9113501	80 Hrs Arr		Tivenan V	SAC P-108	2/18-4/13
9113502	80 Hrs Arr		Tivenan V	SAC P-104	12/24-2/5
9113503	80 Hrs Arr		Tivenan V	SAC P-108	4/14-6/8

THEATRE ARTS 150, THEATRE PRODUCTION 1 UNIT					
Intensive rehearsal experience leading to long-run performance in major departmental productions. May be repeated. Prerequisite: Audition.					
9115001	7:00-9:50pm	MTWTh	Covington B	SAC P-100	2/18-4/4
AND	7:00-8:50pm	F	Thea Staff	SAC P-100	
9115002	7:00-10:05pm	MTWTh	De Mita J	SAC P-105	4/14-5/30
AND	7:00-8:50pm	F	De Mita J	SAC P-105	

THEATRE ARTS 166A, PROGRAMMING & DESIGN PROJECTS 1 UNIT					
Exploration of automated lighting through hands-on utilization of control consoles. Students develop programming, control, and design skills to improve their overall understanding of automated lighting techniques while gaining practical experience. May be repeated.					

W	9116601	9:00-1:05pm	S	Tivenan V	SAC P-100	4/19-4/26
	AND	16 Hrs Arr		Tivenan V	SAC P-100	

Entertainment Lighting...

An Exciting Vocational Program



Study and experiment with today's newest lighting technologies as they are used in Theme Parks, Concert Halls, Sport Centers, Theatres, & Television Studios! Classes are taught in our State-of-the-Art Virtual and Physical Lighting Lab including:

- Whole Hog III, ETC, & Strand Lighting consoles
- Coemar, Martin, & Vari-Lite Intelligent Lighting fixtures
- WYSI LEARN Virtual Lighting Software/Computer work stations
- Ethernet for the Theatre

TKT#	TIME	DAYS	INSTRUCTOR	LOC./RM.	DATES
------	------	------	------------	----------	-------

AUDITIONS

THEATRE PRODUCTION

Theatre Arts 150/250

Enrollment in this class is limited to those who are CAST in departmental productions. Casting is contingent upon passing a performance audition. DO NOT ENROLL IN THEATRE PRODUCTION UNTIL YOU HAVE BEEN CAST.

SPRING 2008 AUDITION SCHEDULE

RUMORS

By Neil Simon

January 12 & 13, 7:00pm, Phillips Hall Theatre

Directed by Barbara Covington

The master of American comedy has spun another smash hit with the hilarious farce, RUMORS. A simple anniversary party turns into a night never to be forgotten when the guests arrive, but where are the hosts?

Casting 5 men and 5 women. Cold readings from the play. Sides will be provided.

CINDERELLA WALTZ

By Don Nigro

April 1 & 2, 7:00pm, Phillips Hall Little Theatre

Directed by John DeMita

Rosey Snow is trapped in a fairy tale world that is both funny and frightening, with her stepsisters Goneril and Regan, a demented stepmother, a lecherous father, a bewildered prince, an unusual fairy godmother, a troll, and a possibly homicidal village idiot. Grotesque farce and romantic fantasy blend in a fairy tale for adults.

Casting 4 men and 5 women. Cold readings from the play. Sides will be provided.

Call the Theatre Department at [714] 564-5666 for full show details.

THEATRE ARTS 166B, ADVANCED PROGRAMMING AND DESIGN PROJECTS 1 UNIT

Continued exploration of automated lighting through a hands-on utilization of control consoles.

Students develop additional design expertise and increase their proficiency in the utilization of automated lights through practical experience. May be repeated.

W 9116602	9:00-1:05pm	S	Tivenan V	SAC P-100	4/19-4/26
AND	16 Hrs Arr		Tivenan V	SAC P-100	

THEATRE ARTS 170, ENTERTAINMENT TECHNOLOGY INTERNSHIP 1-2 UNITS

Supervised field work in one or more of areas of backstage technologies including lighting, sound, and stagecraft. Skills are assessed before placement to match abilities with job requirements. Open entry/open exit. May be repeated. Grade: CR/NCR only.

9117001	1:30-2:00pm	W	Tivenan V	SAC P-105	Full Semester
AND	3 Hrs Arr		Tivenan V	SAC P-105	

THEATRE ARTS 198, READER'S THEATRE WORKSHOP 2 UNITS

A study of acting involving the development of techniques, styles, and theories specific to performing with a script. Provides extensive practical rehearsal experience with varied characters, culminating in a public project performance. May be repeated.

W 9119801	1:30-6:50pm	S	De Mita J	SAC P-105	Full Semester
-----------	-------------	---	-----------	-----------	---------------

THEATRE ARTS 235, ADVANCED TECHNICAL PRODUCTION 1 UNIT

Supervised practical instruction and application in advanced technical theatre production. Students work on more advanced levels of application than in Theatre Arts 135. May be repeated. Prerequisite: Theatre Arts 135.

9123501	80 Hrs Arr		Tivenan V	SAC P-108	2/18-4/13
9123502	80 Hrs Arr		Tivenan V	SAC P-104	12/24-2/5

TKT#	TIME	DAYS	INSTRUCTOR	LOC./RM.	DATES
------	------	------	------------	----------	-------

THEATRE ARTS 250, ADVANCED THEATRE PRODUCTION 1 UNIT

Intensive rehearsal experience at advanced level leading to long-run performance in major departmental productions. Materials and characterizations differ from Theatre Arts 150. May be repeated. Prerequisite: Audition, and Theatre Arts 150.

W 9125003	7:00-10:05pm	MTWTh	De Mita J	SAC P-100	4/14-5/30
AND	7:00-9:50pm	F	De Mita J	SAC P-100	
9125001	7:00-10:05pm	MTWTh	Covington B	SAC P-100	2/18-4/4
AND	7:00-8:50pm	F	Covington B	SAC P-100	

TYPING (SEE BUSINESS APPLICATIONS)

VIDEO PRODUCTION (SEE TV/VIDEO COMMUNICATIONS)

VIETNAMESE

VIETNAMESE 101, ELEMENTARY VIETNAMESE I 5 UNITS

A college level Vietnamese class focusing on pronunciation and intonation, grammar essentials, basic vocabulary; conversation, reading and writing for the expression of ideas. Laboratory assignments. Vietnamese 101 is equivalent to two years of high school Vietnamese.

W 9310102	6:00-8:30pm	F	Tran D	SAC D-302	Full Semester
AND	9:00-11:30	S	Tran D	SAC D-302	
9310101	7:00-9:30pm	MW	Le V	SAC D-214	Full Semester

VIETNAMESE LANGUAGE CLASSES REQUIRE LAB TIME

VIETNAMESE 102, ELEMENTARY VIETNAMESE II 5 UNITS

Continuation of Vietnamese. Further training in pronunciation and grammar, more extensive vocabulary development conversation and composition. Supplementary cultural readings. Appropriate laboratory assignments. Vietnamese 102 is equivalent to the third year of high school Vietnamese. Prerequisite: Vietnamese 101.

9310202	7:00-9:30pm	TTh	Vo V	SAC D-302	Full Semester
---------	-------------	-----	------	-----------	---------------

WELDING

WELDING 008, OXYACETYLENE-ARC WELDING 3 UNITS

Technical knowledge and basic skills needed for occupational oxyacetylene and arc welding processes and applications. Students must furnish safety equipment. (Same as Automotive Technology 008 and Diesel 008.)

\$25.00 material fee required for this course at registration.

9500802	8:00-11:10	TTh	Moreno G	SAC K-101	Full Semester
9500804	6:00-9:10pm	MW	Moreno G	SAC K-101	Full Semester
9500803	6:00-9:10pm	TTh	Moreno G	SAC K-101	Full Semester

WELDING 020, WELDING LABORATORY 0.5-5 UNITS

Independent practice for advanced knowledge and skills development in specific areas of welding technology. Students furnish own equipment. May be repeated. Grade: CR/NCR only. Prerequisite: Concurrent enrollment in any welding course required.

9502001	5:00-5:55pm	W	Moreno G	SAC K-101	Full Semester
---------	-------------	---	----------	-----------	---------------

WELDING 029, ADVANCED ARC WELDING 3 UNITS

Advanced stick electrode skills for structural steel certification. Student to furnish protective safety devices. May be repeated. Prerequisite: Welding 008, satisfactory completion of proficiency exam in arc welding skills, and concurrent enrollment in Welding 020.

\$25.00 material fee required for this course at registration.

9502901	9:00-12:10pm	TTh	Moreno G	SAC K-101	Full Semester
9502904	7:00-10:10pm	MW	Moreno G	SAC K-101	Full Semester
9502903	7:00-10:10pm	TTh	Moreno G	SAC K-101	Full Semester

WELDING 039, INERT GAS WELDING 3 UNITS

Gas shielded welding, TIG and MIG welding of aluminum, mild and stainless steel. Students to furnish protective safety devices. May be repeated. Prerequisite: Welding 008 and concurrent enrollment in Welding 020.

\$25.00 material fee required for this course at registration.

9503901	9:00-12:10pm	TTh	Moreno G	SAC K-101	Full Semester
9503904	7:00-10:10pm	MW	Moreno G	SAC K-101	Full Semester
9503903	7:00-10:10pm	TTh	Moreno G	SAC K-101	Full Semester

WOMEN'S STUDIES

WOMEN'S STUDIES 101, INTRODUCTION TO WOMEN'S STUDIES 3 UNITS

Survey of social trends, issues, opportunities and topics focusing on women. Includes sex, gender, family, feminism, rape, literature, art, science, work, law, and history.

9610102	9:45-11:10	TTh	Davis J	SAC D-106	Full Semester
9610104	7:00-10:10pm	Th	Davis J	SAC C-214	Full Semester

SERVICES FOR STUDENTS

SERVICE HOURS

ADMISSIONS HOURS – first floor of the Administration Building

Santa Ana College	(714) 564-6015
Monday–Thursday	8:00 am to 8:45 pm
Friday	8:00 am to 4:30 pm
Saturday	8:30 am to 12:30 pm on 2/23/08 only

REGISTRATION HOURS

November 26, 2007– February 22, 2008 (closed 12/24/07–1/1/08)
located on first floor of Johnson Campus Center, U-102

Santa Ana College	(714) 564-6019
Monday–Thursday	10:00 am to 6:45 pm
Friday	10:00 am to 3:45 pm

CASHIER'S OFFICE & PHOTO I.D. HOURS

first floor of Administration Building, Room S-104

Santa Ana College	(714) 564-6965
Monday–Tuesday	9:00 am to 7:00 pm
Wednesday–Thursday	9:00 am to 5:00 pm
Friday	9:00 am to Noon

Pay fees by phone (714) 564-6400

Pay fees on-line www.sac.edu

BOOKSTORE HOURS

located on first floor of Johnson Campus Center

Santa Ana College Bookstore	(714) 564-6435
Monday–Thursday	7:45 am to 8:00 pm
Friday	7:45 am to 12:30 pm
Saturday	(9:00 am to Noon on 2/23 only)

BOOKSTORE CHECK CASHING POLICY

Personal checks made payable to SAC are accepted in the amount of purchase.
Students must present a current student ID.

CREDIT CARDS

Current ID required and the cardholder must be present. Visa, MasterCard, and Discover accepted.

BOOKSTORE REFUND POLICY

Textbooks for full semester courses can be refunded within the first two weeks of the first day of classes with current register receipt.
Test materials/supplies also available in VENDING machine located in Cesar Chavez Building and at the Don Express.

LIBRARY HOURS

Santa Ana College Nealley Library	(714) 564-6700
Monday–Thursday	8:00 am to 9:00 pm
Friday	8:00 am to 4:00 pm
Saturday	9:00 am to 3:00 pm
Sunday	Closed

LIBRARY USE POLICY

Current enrollment and a valid photo I.D. card is required to check out materials.

CAFETERIA HOURS

located on second floor of Johnson Campus Center

Santa Ana College	
Monday - Thursday	7:30 am to 8:30 pm
Friday (CLOSED FRIDAYS DURING SUMMER)	7:30 am to 1:00 pm

DON EXPRESS HOURS (subject to change)

Snacks, sandwiches, drinks, school supplies, test forms, and magazines.

Santa Ana College

located between Dunlap Hall and Phillips Hall

Monday–Thursday	7:30 am to 8:30 pm
Friday	7:30 am to 12:30 pm
Saturdays	7:30 am to 12:30 pm

SERVICE PROGRAMS

ASSOCIATED STUDENTS

SAC Johnson Center, Room U-100C **(714) 564-6208**

The Associated Students was established to provide students with government and leadership experience. Opportunities are available to become involved in campus committees and councils as a student representative. Learn first hand about group dynamics and decision making, event programming, and running effective meetings. Additionally, there are many student clubs and organizations for you to join. Contact the Student Activities Office for information regarding student government, Inter-Club Council, clubs/student organizations and the Student Leadership Institute.

CAREER/JOB RESOURCE CENTER

SAC Library Building 2nd floor, Room L-225 **(714) 564-6254**

The SAC Career/Job Resource center offers access to computerized resources and hard copy information on careers, training programs, and job placement services as well as workshops. Individuals and entire classes can utilize the center to explore careers keyed to interests, skills, personality, and values. Information is available on employment trends and salaries, locally, nationally, and on the international level.

The Career/Job Resource Center provides all the resources necessary for students to find a satisfying major, set career goals, and obtain successful employment.

UNDECIDED MAJORS WORKSHOPS

FREE workshops designed specifically to assess students' career interests. Provides decision-making information, which can lead to more effective educational goals associated with various majors. Workshops are **open to the community**. Call for dates and times.

EMPLOYMENT PREPARATION WORKSHOPS

Employment Preparation Workshops are offered on an ongoing basis in the following areas: Résumé Preparation, Interview Skills, Job Search Techniques, and Personality Inventory. Call for dates and times.

CHILD DEVELOPMENT SERVICES

Executive Director (2323 N. Broadway, Santa Ana) **(714) 480-7546**

Child care services are provided at all college sites for children of students. Fees vary according to student income. The centers serve children 6 months to 5 years of age. For information call any center below:

- **Santa Ana College** at (714) 564-6894.
- **Centennial Education Center** at (714) 241-5739.
- **Santiago Canyon College** at (714) 628-4890.
- **Orange Education Center** at (714) 628-5925.

COMMUNITY SERVICES

SAC Administration Building, S-204 **(714) 564-6594**
Also at www.sac.edu/cms **FAX (714) 564-0240**

The Community Services program offers courses for both adults and children in computers, personal growth, dance, arts & crafts, money matters & investments, recreation, business, careers, travel tours, and more. For registration information, or to obtain a brochure with a full listing of events, call or visit our office listed above.

COUNSELING SERVICES

SAC Administration Building, 1st Floor, Room S-109 **(714) 564-6100**
Centennial Education Center **(714) 241-5720**

RSCCD Counseling Services provide a variety of programs and procedures through which individuals are brought into the instructional program, assisted in career planning and development, assisted in planning for and pursuing courses of study, and provided avenues for obtaining employment. For more information, log on: www.sac.edu/students/counseling/services.htm

... SERVICES ...

SERVICE PROGRAMS (continued)

Online counseling now available!
www.sac.edu/online_counseling

DISABLED STUDENTS PROGRAMS AND SERVICES

ASSISTIVE TECHNOLOGY CENTER

SAC Johnson Center, Room U-103 (714) 564-6260

The center provides computer assisted instruction through the use of assistive technology for disabled students.

COMMUNICATIONS DISABILITIES/ ACQUIRED BRAIN IMPAIRMENT PROGRAM

SAC Planetarium, Room M-105 (714) 564-6280

TTY (Telecommunications Device For The Deaf) (714) 564-6287

Students with speech, hearing, or language difficulties may receive assistance by signing up for Speech Communication N51. Students with verifiable acquired brain impairments receive program planning, registration assistance, assessment, computer assisted instruction, and access to support groups.

DEAF and HARD OF HEARING PROGRAM AND SERVICES

SAC Johnson Center, Room U-107 (714) 564-6283

TTY/TDD (Telecommunications Device For The Deaf)..... (714) 564-6284

Sign language, note taking supplies, assistive listening devices and tutors are provided for deaf and hard of hearing students.

DEVELOPMENTALLY DELAYED LEARNERS

SAC Johnson Center, Room R-141 (714) 564-6273

Students who are Developmentally Delayed Learners receive support services to help them function independently and successfully in the college environment.

LEARNING DISABILITIES

SAC Johnson Center, Room U-103 (714) 564-6260

Centennial Education Center, Room D-101 (714) 564-5135

A program for students with learning deficits severe enough to affect classroom performance. Assessment, tutoring, and special classes.

PHYSICAL DISABILITIES

SAC Russell Hall, Room R-101 (714) 564-6295

Services include registration assistance, parking, elevator/gate passes, Adaptive Exercise Science, special equipment loans, wheelchair loans, personal and academic advisement, mobility and learning assistance.

PSYCHOLOGICAL DISABILITIES

SAC Johnson Center, Room U-103 (714) 564-6260

The Psychological Disabilities Program is designed to support and assist students with mental and emotional disorders who are attempting to function more independently.

WORKABILITY III

SAC Library Building, Room L-220 (714) 564-6255

The objective of this program is to provide work readiness activities, job development, and job placement for students with disabilities.

EXTENDED OPPORTUNITY PROGRAM AND SERVICES (EOPS)

SAC Johnson Center Room U-101 (714) 564-6232
(Hours: Mon-Thur 8am-6:30pm, Fri 8am-12pm)

The Extended Opportunity Program & Services (EOPS) is a statewide program created to provide opportunities and services to underserved students from low-income and academically disadvantaged backgrounds. The program and services are designed to facilitate the college experience and to assist students to achieve their educational goals. EOPS also houses the CARE program, which provides additional support services for single parents with children under the age of 14. For more information and eligibility criteria, please stop by or call the EOPS office at one of the above locations and/or numbers listed.

FINANCIAL AID

SAC Johnson Center, Room U-221 (714) 564-6242
(Hours: Mon 9am-6pm, Tue-Thur 9am-5pm, Fri 9am-12pm)

The Financial Aid Office administers federal and state student aid programs designed to assist students who are unable to meet the cost of education. These programs include the Board of Governors Fee Waiver, Cal Grant programs, Federal Pell Grant, Federal Supplemental Educational Opportunity Grant, Federal Perkins Loan, Federal Work-Study and the Federal Family Educational Loan Programs (Stafford and PLUS loans). Since the application process can take a number of weeks, students are encouraged to complete the Free Application for Federal Student Aid (FAFSA) in early Spring (January-May) for the following Fall semester. In addition to the FAFSA, applicants for financial aid will be notified if any additional documents are needed to complete their application. **REMINDER: IT IS NOT TOO LATE TO APPLY!** You could still qualify for financial aid for Fall and Spring. Complete the Free Application for Federal Student Aid now! Contact the Financial Aid Office for further details.

HEALTH AND WELLNESS CENTERS

SAC Johnson Center, Room U-120 (714) 564-6216
(Hours: Mon-Thur 9am-7pm)

Currently enrolled students who have paid the Health Fee are eligible to use the services available in the Health Centers. A Registered Nurse is available at all times. Physicians, Psychologists, and doctoral level Psychology Interns are available by appointment only. Services include but are not limited to: first-aid, diagnosis and treatment of acute illness, pap smears, low cost birth control pills and condoms, emergency contraception, hearing and vision screening, and psychological services.

PSYCHOLOGICAL SERVICES – Currently enrolled students who have paid the Health Fee are invited to visit the Santa Ana College Health Center for individual and group counseling, on a short-term basis, for personal problems, stress, and low self-esteem, as well as other mental health concerns. If appropriate, referrals are made to community agencies. Appointments can be made by calling or visiting the Health Center location listed above. Classes relating to mental health issues which provide education and support, are also offered by Psychological Services (see class schedule under Special Services).

MESA (Math, Engineering, & Science)

SAC Administration Building, Room S-132 (714) 564-6373
(Hours: Mon-Thur 8am-7pm, Fri 8am-4pm)

The MESA program is an academic program that supports educationally disadvantaged community college students to excel in math, engineering, and science so they can transfer to four-year institutions as majors in these fields. Services include tutoring, advisement, workshops, and scholarships.

STUDENTS: Web access to student records and registration is on its way!
Go to www.sac.edu – click on online records and update your student profile with your personal email address. **We'll be in touch.**

... SERVICES ...

SERVICE PROGRAMS (continued)

SCHOLARSHIP PROGRAM

SAC Administration Building, Room S-204(714) 564-6478
(Hours: Mon-Thur 8:30am-4pm)

The SAC Scholarship Program offers scholarships to incoming, continuing and graduating/transferring SAC students. The program opens during the first week of November and closes the first week in March. Information and application packets are available in the Scholarship Program office. Awards are announced during a special ceremony in May and funds are available for the following fall semester. Help in how to apply for scholarships is also available.

The Scholarship Program is also available to work with interested business, corporations and individuals to establish new scholarships. Scholarships can be structured to meet the wishes and parameters of the donor and may be given one-time only, in memoriam, in perpetuity, or on an annual renewable basis. For more specific information about the SAC Scholarship Program, contact the Scholarship Program directly at (714) 564-6478.

SERVICE LEARNING

SAC Johnson Center, Room U-100A.....(714) 564-6362

The Service Learning Center is responsible for developing, implementing, and administering comprehensive programs and activities related to community service volunteerism, community partnerships, and service learning. The program connects with many local nonprofit agencies, each of which offer numerous volunteer opportunities. Students then match their skills and interests to the needs of the community agencies and gain valuable personal experience. Many instructors utilize service learning as a course requirement in order to connect student classroom learning with real life experience.

STUDENT PLACEMENT

SAC Administration Building, Room L-222.....(714) 564-6201
(Hours: Mon-Thur 8am-5pm, Fri. 9am-12pm)

The Student Placement Office assists currently enrolled students in obtaining on-campus student assistant/work study employment. The Student Placement Office also provides housing listings placed by members of the community.

STUDENT SUPPORT SERVICES PROGRAM (TRIO)

SAC Johnson Center, Room U-102B.....(714) 564-6843
(Hours: Mon-Thur 8am-5pm, Fri 8am-12pm)

The Student Support Services Program (TRIO) is a federally funded program designed to improve the retention, transfer and graduation rate of low income, first-generation and disabled college students. The SSS program provides students with academic, personal and career counseling, tutoring, specialized workshops, field trips and assistance in transferring to a four-year university.

TEACHER EDUCATION CENTER

SAC Administration Building, Room S-132(714) 564-6352
(Hours: Mon-Thur 8am-7pm, Fri 8am-4pm)

The Center for Teacher Education is a resource center which offers information, academic advisement, and support for students interested in pursuing a career in teaching with an emphasis in preparing students for employment in local public elementary and secondary schools.

UNIVERSITY TRANSFER CENTER

SAC Administration Building, Room S-132(714) 564-6165
(Hours: Mon-Thur 8am-7pm, Fri 8am-4pm)

The University Transfer Center provides information and assistance to students preparing for transfer to baccalaureate granting institutions. Transfer services include appointments with university representatives and college fairs at Santa Ana College, as well as in-state and out-of-state university field trips. Our *Counseling N45 Orientation to College* and *Transfer Success Information Night* programs inform both parents and students about the transfer process and how to successfully achieve their academic goals. Additional information sessions focus on UC and CSU admissions, guarantee transfer programs, scholarships and internship opportunities. Students may also use our computers to access a complete digital resource library of university catalogs and videos.

TUTORIAL CENTER

SAC Johnson Center, Room U-103(714) 564-6260
(Hours: Mon-Wed 9am-7pm, Thur 9am-5pm, Fri & Sat 9am-1pm)

Free tutoring in a wide variety of subject areas is available at the Tutorial Learning Center. Call or visit the Center to schedule your appointment today. Services include tutoring, group study sessions, exam reviews and study skills information. Make the most of your educational experience at SAC by checking out this valuable resource.

VETERANS SERVICES

SAC Administration Building, Room S-216.....(714) 564-6050
(Hours: Mon-Thur 10am-6pm, closed Friday)

RSCCD offers services to Veterans with a refresher program that starts at any time, over 110 Associate Degree programs, job placement, financial aid, counseling, tutoring, and Learning Center services. Visit the Veterans Center in the east wing of the Administration building or call to find out the requirements and benefits for programs to which you may be entitled.

SPRING 2008 PSYCHOLOGICAL SERVICES: GOT STRESS?

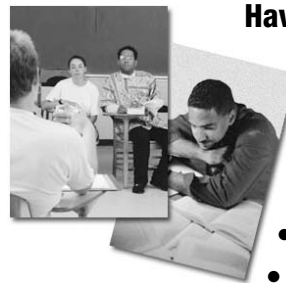

Having difficulty with:

- Friends?
- Family?
- Relationships?
- Self-esteem?
- Time Management?
- Test Anxiety?

Psychological Services are available to ensure that students have the support as needed while working on their educational/career goals at Santa Ana College. A team of psychologists and interns can help students find solutions to life problems through individual or group counseling.

All services are confidential. Services are free to currently enrolled students. Come visit us at the Student Health and Wellness Center on the first floor of the Johnson Center (U-120) or call (714) 564-6261

**For individual psychological
counseling appointments contact:**

**Santa Ana College Health Center
714 / 564-6216
Johnson Center, Room U-120,**

ACADEMIC PLANNING . . .

PREREQUISITES, COREQUISITES, & READING LEVELS

IMPORTANT DEFINITIONS

If you should see the words **Prerequisite**, **Corequisite**, or **Advisory Reading Level** in the class schedule, it is important for you to understand the definitions of these terms. Note that prerequisites and corequisites can be challenged. See *Prerequisite Challenge Policy*, on this page, for more information.

PREREQUISITE indicates a condition of enrollment that a student is required to meet in order to demonstrate current readiness for enrollment in a course or educational program. A prerequisite represents a set of skills or a body of knowledge that a student must possess prior to enrollment and without which the student is highly unlikely to succeed in the course or program. Students will not be permitted to enroll in such courses and programs without the appropriate prerequisite.

COREQUISITE indicates a condition of enrollment consisting of a course that a student is required to simultaneously take in order to enroll in another course. A corequisite represents a set of skills or a body of knowledge that a student must acquire through concurrent enrollment in another course and without which the student is highly unlikely to succeed. Students must concurrently enroll in the corequisite course.

ADVISORY READING LEVELS indicate desirable reading skills for a course. These are recommended but not mandatory prior to enrollment.

WHAT THE LEVELS FOR ADVISORY READING LEVELS MEAN

LEVEL 2	Minimum reading level: Qualification for Reading N90 <i>determined by</i> reading placement test.
LEVEL 3	Qualification for Reading N90 on reading placement test.
LEVEL 4	Qualification for Reading 100 on reading placement test.

*Levels 2 and 3 are approximately 8th grade reading level. This is the minimum reading proficiency level required for high school graduation in California. Short newspaper articles with common vocabulary are often about 8th grade reading level. Students with this level of reading may have difficulty with texts containing complex ideas and new vocabulary.

**Level 4 is approximately 10th grade reading level. This is the minimum level required for an AA/AS degree at RSCCD. Longer newspaper articles with content-specific vocabulary are often about 10th grade reading level. Motivated students with this level of reading skill can often handle texts where new vocabulary and concepts are explained.

PREREQUISITE CHALLENGE POLICY AND PROCEDURES

COURSE PREREQUISITE POLICY

Prerequisite means the preparation or previous course work considered necessary for success in the course. The College requires students to complete prerequisites as pre-enrollment preparation. Prerequisites which are listed in the College Catalog include:

1. Courses for which specific prerequisites have been established,
2. Sequential course work in a degree-applicable program, and
3. Courses in which an equivalent prerequisite exists at a four-year transfer college or university.

Questions about prerequisites are best resolved with a counselor or instructor prior to the first day of class.

PREREQUISITE CHALLENGE PROCESS

A prerequisite challenge requires written documentation explaining alternative course-work, background or abilities which adequately prepare the student for the course. A Prerequisite Challenge Form can be obtained from the appropriate division office. Prerequisites may be challenged for one or more of the following reasons:

1. The college has not developed the prerequisite according to its established procedures or has not developed the prerequisite in accord with existing statutes.
2. The prerequisite is discriminatory or is being applied in a discriminatory fashion.
3. The College has not made the prerequisite course reasonably available.
4. The student has documented knowledge and abilities equivalent to those specified in the prerequisite course.

The challenge will be reviewed by a committee consisting of the division dean, or designee, department chair, or designee, and one department or division representative or designee.

If space is available in a course when a student files a challenge to the prerequisite or corequisite, the district shall reserve a seat for the student and resolve the challenge in a timely manner. If no space is available in the course when a challenge is filed, the challenge shall be resolved prior to the beginning of registration for the next term and, if the challenge is upheld, the student shall be permitted to enroll if space is available when the student registers for that subsequent term.

Note: Students who are challenging a course which is a requirement for a degree or certificate may wish to use the Credit by Examination process to receive credit for the challenged course.

RSCCD ASSESSMENT INFORMATION COURSE EXCEPTION LIST

GROUP I - The courses listed below do not have advisory reading levels and are **EXEMPT** from participation in the matriculation process (orientation, assessment, advisement, and counseling). However, students are encouraged to complete assessment and other matriculation services (see page 12).

MUSIC - Music 113AB, 114AB, 115ABCD, 132, 133, 134, 135, 136, 141, 171, 175, 176, 215ABCD, 241

GROUP II - The courses listed below have advisory reading levels and are **EXEMPT** from participation in the matriculation process (orientation, assessment, advisement, placement, and follow-up). However, students are encouraged to complete assessment and other matriculation services (see page 12).

ACCOUNTING - All Accounting Courses

APPRENTICESHIP - All Apprenticeship Courses

ART - Art 119, 121AB, 122, 124, 128, 130, 131, 140AB, 141, 143, 151, 151, 153, 155, 156, 160, 161, 171, 175A, 182, 183, 184AB, 186, 196AB, 197AB, 221, 230, 231, 232, 233, 234, 240, 241, 242, 243, 250, 251, 282, 283, 296, 298

BANKING - All Banking Courses

BUSINESS - All Business Courses

COMPUTER SCIENCE - All Computer Science Courses

CONTINUING EDUCATION NURSING - All Continuing Education Nursing Courses

DANCE - Dance 112, 201AB, 202, 204AB, 205, 206AB, 209, 210, 213, 214, 215AB, 216, 219AB, 220, 221, 230, 232, 240, 260, 298

DRAFTING TECHNOLOGY - All Drafting Technology Courses

ENGINEERING - All Engineering Courses

ENVIRONMENTAL STUDIES - All Environmental Studies Courses

EXERCISE SCIENCE - E.S. Activities, E.S. Adaptive Activities, E.S. Aquatics, E.S. Fitness, E.S. Intercollegiate Athletics

FIRE ACADEMY - All Fire Academy Courses

FRENCH - French 101, 195, 201 & 202

MANUFACTURING TECHNOLOGY - All Manufacturing Technology Courses

MANAGEMENT & MARKETING - All Management & Marketing Courses

MUSIC - Music 121, 122, 123, 124, 161, 162, 163, 164, 165, 185, 186, 187, 188, 213, 214, 215, 216, 217

PHOTOGRAPHY - Photography 165, 180, 181, 182, 183, 195, 200, 292, 293, 294

PUBLIC WORKS - All Public Works Courses

SPANISH - Spanish 101, 201, & 202

TELEVISION/VIDEO PRODUCTION - Television/Video Production 111, 112, 114, 141, 142, 150, 160, 181, 182, 185, 186, 211, 280, 298

THEATRE ARTS - Theatre Arts 112, 113, 131, 132, 133, 135, 150, 230, 235, 250, 280

TRAVEL AND TOURISM - All Travel and Tourism Courses

WATER UTILITY SCIENCE - All Water Utility Science Courses

... PLANNING ...

EDUCATIONAL OPTIONS — ASSOCIATE DEGREE

SANTA ANA COLLEGE ASSOCIATE DEGREE REQUIREMENTS

To qualify for an associate degree, the candidate must meet the following requirements:

COURSES: Sixty units in the following five categories:

- I. Major Requirements:** Each degree and certificate program specifies courses required for the major. Students must complete these courses with a grade of "C" or better. See the Instructional Programs section of the catalog.
- II. General Education Requirements:** 21 semester units of general education which include one course or more as indicated in group requirements A, B, C, D, and E.
Courses from the major may be used to satisfy individual group requirements but those units may not be counted as part of the 21 semester units of general education.
- III. Lifelong Understanding and Self-Development:** The college requires that students select three units from category F in addition to the minimum 21 units in Groups A, B, C, D, and E.
- IV. Skills Proficiency Requirements:** The college requires proficiency in basic learning skills in mathematics, reading, and oral communication, as found in Required Proficiencies.
- V. Computer Skills and Applications Requirement:** See page 91.

Note: The requirements in parts II, III, IV, and V above also may be met by completion of CSU General Education Breadth certification requirements, by completion of the Intersegmental General Education Transfer Curriculum requirements, by submitting a transcript showing completion of a bachelor's degree at an accredited institution, or by submitting a transcript showing completion of an associate of arts or associate of science degree from an accredited California institution within a ten-year period of finishing major requirements (I) at the college.

Courses numbered less than 100 and preceded by "N" are NOT applicable to the Associate Degree.

Grade Point Average: A cumulative G.P.A. of at least 2.0 (C).

Residency: At least 12 units completed at SAC (at least six of the units must be in courses required for the major unless otherwise noted in the catalog).

Petition for Graduation and Catalog Rights: Petitions for graduation should be filed in the Office of Admissions and Records one semester before the student expects to graduate. Students who maintain continuous enrollment in at least one regular semester or session of a catalog year (Fall, Intersession, Spring, or Summer) at Santa Ana College or Santiago Canyon College may elect to meet the associate degree or certificate requirements in the SAC catalog in effect at the time of first enrollment, or may choose the catalog requirements from any one year of subsequent continuous enrollment at SAC/SCC. A student who has an interruption of attendance must use the catalog at the time of readmission or one of subsequent continuous enrollment. Commencement exercises are held once a year at the end of the spring semester for those students who complete the requirements for graduation during the year or the summer session. Note: Transcripts from all colleges attended must be on file.

I. Major Requirements

See the *Instructional Programs* section of the SAC catalog.

II. General Education Requirements for the Associate Degree Plan A — 2007-2008

Note: A single course may be used to meet only one category requirement.

- A. NATURAL SCIENCES** (minimum 3 units)
- Anthropology 101, 101L
 - Astronomy 109, 110 or 110H, 140, 150
 - Biology 109 or 109H, 109L, 149, 159, 177, 200, 211, 239, 259
 - Chemistry 109, 119, 209, 219 or 219H
 - Earth Science 110 or 110H, 115, 150 or 150H
 - Environmental Studies 109, 140, 200, 259
 - Geography 101, 101L
 - Geology 101, 101L, 140, 150 or 150H, 201
 - Physical Science 117, 118
 - Physics 109, 210, 217, 279
 - Science 200

- B. SOCIAL AND BEHAVIORAL SCIENCES** (minimum 6 units)
- 1. American Institutions** (minimum 3 units)
History 118, 120 or 120H, 121 or 121H, 122
Political Science 101 or 101H
 - 2. Social Science Elective** (minimum 3 units)
Anthropology 100 or 100H
Criminal Justice 101
Economics 120, 121
Geography 100 or 100H, 102 or 102H
History 101 or 101H, 102 or 102H
Human Development 107, 110
Political Science 101 or 101H
Psychology 100 or 100H
Sociology 100 or 100H
- C. HUMANITIES** (minimum 3 units)
- Anthropology 104 or 104H
 - Art 100 or 100H, 101, 102, 105, 110
 - Dance 100 or 100H, 105
 - English 104 or 104H
 - Foreign Language:
 - French 101, 102, 201 or 201H, 202 or 202H
 - Japanese 101, 102
 - Spanish 101 or 101H, 102 or 102H, 201 or 201H, 202 or 202H
 - Vietnamese 101, 102
 - Interdisciplinary Studies 121, 200
 - Literature:
 - English 102 or 102H, 231, 232, 233ABCD, 241, 242, 270, 271, 272
 - Music 101 or 101H, 102 or 102H, 110, 211
 - Philosophy 106 or 106H, 108, 112, 118
 - Sign Language 110, 111B, 112, 116
 - TV/Video Communications 101, 103, 104, 105 or 105H
 - Theatre Arts Theatre Arts 100, 103, 104, 105, 233ABCD
- D. CULTURAL BREADTH** (Three units required from D1 or D2)
- 1. Ethnic Studies / Women's Studies**
Anthropology 104 or 104H, 125
Art 103, 104, 106
Asian American Studies 101
Black Studies 101
Chicano Studies 101
English 104 or 104H
E.S. Health Education 102
Ethnic Studies 101 or 101H, 102 or 102H
History 123, 124 or 124H, 125, 127, 146, 150, 151, 153, 160, 161, 181
Human Development 221
Literature: English 245, 246, 278
Music 103
Nutrition and Food 118
Psychology 170
Speech Communication 103 or 103H, 206 or 206H
Women's Studies 101, 102, 201
 - 2. International Perspective**
Anthropology 100 or 100H
Business 106 or 106H
Criminal Justice 209
Dance 105
English 271, 272
E.S. Professional 150
Geography 100 or 100H, 102 or 102H
Interdisciplinary Studies 117H
Music 102 or 102H
Philosophy 112
Theatre Arts 105

REQUIREMENTS CONTINUED ON NEXT PAGE . . .

... PLANNING ...

ASSOCIATE DEGREE (continued)

II. General Education Requirements for the Associate Degree (continued)

D. LANGUAGE AND RATIONALITY (continued)

E. LANGUAGE AND RATIONALITY (minimum 6 units)

- 1. English Composition** (minimum 3 units)
Courses fulfilling the written composition requirement include both expository and argumentative writing.
The English composition requirement may be met by:
*a. English 061, 101 or 101H, EMLS 112.
b. Satisfactory score on English Department Proficiency Examination in composition. Students successfully completing the proficiency examination may earn 3 units in English 061 OR EMLS 112.
*With a grade of "C" or better.
- 2. Communication and Analytical Thinking** (minimum 3 units)
Includes mathematics, logic, statistics, computer languages and programming and related disciplines.
Computer Science 100, 105, 111
Counseling 144
English 103 or 103H
Interdisciplinary Studies 111
Mathematics 080, 105, 140, 145, 150, 160, 170, 180 or 180H, 185, 219 or 219H, 270, 275, 280, 290, 295
Philosophy 110 or 110H, 111, 144
Social Science 219 or 219H
Speech Communication 102, 140, 145

F. LIFELONG UNDERSTANDING & SELF-DEVELOPMENT

(minimum 3 units) **Note:** Take one course from each group. No more than one (1) unit may be counted from F2.

1. Completion of one of the following:
Business 130
Counseling 100, 101, 116, 120, 124, 125, 128
E.S. Health Education 101, 102, 104, 120
E.S. Professional 125, 140
Family & Consumer Studies 120
Fashion Design Merchandising 103
Human Development 102, 107
Interdisciplinary Studies 111, 155
Library and Information Studies 100
Mathematics 030
Nutrition & Food 115 or 115H
Philosophy 111
Psychology 140, 230
Sociology 112
2. Completion of one of the following:
Dance 102, 201A, 201B, 206A, 206B, 219A, 219B
E.S. Activities 107, 127, 130, 132, 140, 150, 155, 160, 169, 180, 185, 200, 210, 220, 226, 235, 240, 245, 260, 265, 270, 280, 290, 292
E.S. Adaptive Activities 201, 202, 205, 206, 208, 211, 220
E.S. Aerobic Fitness 140, 143, 144, 150, 155, 156, 158, 160
E.S. Aquatics 201, 204, 205, 209
E.S. Fitness 100, 101, 102, 105, 108, 109, 110, 115, 116, 119, 120, 145, 147, 170
E.S. Intercollegiate Athletics 124, 125, 126, 127, 128, 201, 202, 203, 204, 205, 206, 207, 208, 209, 210, 211, 212, 213, 214, 215, 216, 217, 218, 219, 220, 221, 222

This requirement (F) is met for Fire, Nursing, and Occupational Therapy Assistant majors by completion of their major.

Note: A single course may be used to meet only one category requirement (A-F) in section II. However, a course may be used to meet both a required proficiency or computer requirement, as well as one of the categories of General Education Courses on Plan A. Courses which meet the requirements for Part II of Plan A at Santiago Canyon College will automatically meet the identical requirements for Part II of Plan A at Santa Ana College.

III. Lifelong Understanding and Self-Development

The college requires that students select three units from category F (see above) in addition to the minimum 21 units in Groups A, B, C, D, and E.

IV. Required Proficiencies

Courses listed in this requirement can also be used to meet General Education Requirements in groups A through F where appropriate. Courses taken to meet these proficiencies must be completed with a grade of C or better.

A. READING

1. Satisfactory score on the SAC/SCC Reading Placement Test at the time of initial placement testing, OR
2. Satisfactory score on a Reading Department Test, OR
3. Successful completion of Reading 100A, OR
4. A "C" grade, or better in 9 units of general education courses for the Associate Degree in Areas A (Natural Sciences) - 3 units; B (Social and Behavioral Sciences) - 3 units each in B1 and B2.

B. MATHEMATICS

1. Completion of Mathematics 060 or any other 3 unit mathematics course numbered above the level of 060 **OR**
2. Score on the SAC/SCC mathematics placement test indicating placement in a mathematics course numbered above the level of 060.

C. ORAL COMMUNICATION

Completion of 3 units from the following: Speech Communication 101 **OR** 101H (Interpersonal Communication), Speech Communication 102 (Public Speaking), Speech Communication 140 (Argumentation and Debate), Speech Communication 145 (Group Dynamics), Speech Communication 152 (Oral Interpretation).

V. Computer Skills and Applications Requirement

Courses meeting the computer skills and applications requirement include the theories and concepts of computer technology and/or the applied technology of computers in various disciplines. Such courses will either focus on computer technology as a discipline or will focus on computer application programs as a major component of the course. This requirement is met by completing one of the following:

- A. Completion of any of the following majors or programs which require courses in computer technology and/or applied technology:
Automotive Technology
Communications - Journalism Option Degree A-Print Journalism
Communications - Journalism Option Degree B-Broadcast Journalism
Diesel
Electronics
Engineering
Fashion Design Merchandising
Human Development
Library Technology
Manufacturing Technology
Music Degree
Nursing
Pharmacy Technology
TV/Video Communications Degree
- B. Completion of one of the following courses with a grade of C or better:
Art 195
Business 150
Business Applications 179
Computer Science 100
Paralegal 120
- C. Students may challenge courses under "B" above, through Credit by Examination. Students should plan to schedule a Credit by Examination test at least one semester prior to anticipated graduation. This will allow students to enroll in a course if exam is not passed. Students follow the Credit by Examination procedure listed in the catalog.

... PLANNING ...

ASSOCIATE DEGREE (continued) AND CERTIFICATE PROGRAMS

PROFICIENCY EXAMINATIONS FOR THE ASSOCIATE DEGREE

Students may satisfy the English writing, reading, and computational skills required for the Associate Degree by achieving a satisfactory score on the appropriate proficiency test in each skill area or by fulfilling other options as listed under the Associate Degree Requirements in the class schedule.

Students taking the proficiency examinations must be currently enrolled at Santa Ana College or Santiago Canyon College. Students who do not achieve a satisfactory score on the English Writing Proficiency Examination may not rechallenge that examination but must satisfactorily complete an approved course as listed in the graduation requirements.

ENGLISH WRITING PROFICIENCY EXAMINATION

1. Fill out a Credit by Examination form at the Admissions Office and have eligibility verified.
2. Pay 3 units times the current rate.
3. To make arrangements to take the English Writing Proficiency Examination at Santa Ana College, contact the Humanities/Social Sciences Division Office at (714) 564-6500 (D-435).

Note: Three units in English 061 or ESL 112 are awarded for successful completion of the English Proficiency Examination. Recommended course to prepare for the examination is English N60 for native English-speaking students or ESL 110 for non-native English-speaking students.

Date for the English Writing Proficiency Examination:

- Thursday, October 18, 2007, 2:00-4:00 pm, SAC Room D-435

READING PROFICIENCY EXAMINATION (I.D. required)

1. Contact the Reading Center, SAC Dunlap Hall, room 307 and make arrangements to take the Reading Proficiency Exam. Any questions call (714) 564-6569

MATHEMATICS PROFICIENCY EXAMINATION

1. Contact the Math Study Center, SAC Library, room 204, and make arrangements to take the Math Department Proficiency Examination.

CERTIFICATE PROGRAMS

A certificate is a verification of competency in a particular occupational skill. Certificate programs normally include only those courses which have a direct bearing upon specialized occupational competency since the certificate has the sole objective of immediate employment in a specialized area. For this reason there is no general education requirement in a certificate program. Santa Ana College certificate programs leading to immediate employment are listed in the catalog. To qualify for a certificate of completion, a candidate must meet the following requirements:

1. **Courses:** Courses are designated for the specific certificate.
2. **Grades:** At least a C grade in each course required for the certificate, unless otherwise specified. Credit by Examination may also be used to gain credit for required courses.
3. **Credit/No Credit:** A credit/no credit course is acceptable toward the certificate if it is required for the certificate and (a) offered on a credit/no credit basis only or (b) if the credit/no credit is earned on the basis of credit by examination.
4. **Residency:** Twelve units completed at SAC/SCC. (At least six of the units must be in courses required for the certificate, unless otherwise noted in the catalog.)
5. **Petition:** Petition for certificate filed by the student with the Office of Admissions and Records at Santa Ana College or Santiago Canyon College.

SANTA ANA COLLEGE RATES OF STUDENT PROGRESS

• STUDENT RIGHT-TO-KNOW ACT

The rates below are placed here in accordance with the federally mandated Student Right-To-Know Act.

Of the degree, certificate or transfer seeking first-time freshman students who entered Santa Ana College in Fall 2003, the "completion rate" represents those students who earned an Associates Degree, certificate of completion, or 56 UC/CSU transferable credits within three years.

2003 COHORT COMPLETION RATE

STATE	36%
SAC	32%

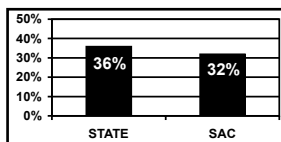

The "transfer rate" represents non-completer students who transferred to any other two- or four-year institution within three years.

2003 COHORT TRANSFER RATE

STATE	17%
SAC	25%

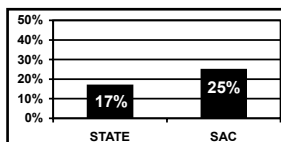

These rates do not represent the success rates of the entire student population at SAC nor do they account for student outcomes occurring after this three-year tracking period.

Academic Planning Questions?

www.sac.edu/online_counseling

Can't find the class you need?

It may be waiting for you at
Santiago Canyon College!

View SCC's class schedule at
www.sccollege.edu/schedule

SCC's class schedule is included in this booklet.

Hurry! Class sizes are limited.

MORE EDUCATIONAL OPTIONS ...

GENERAL EDUCATION BREADTH REQUIREMENTS FOR THE CALIFORNIA STATE UNIVERSITY (CSU)

Plan B: 2007–2008 Santa Ana College

These requirements apply to all students. Students planning to graduate from one of the 23 campuses of the California State University must complete 48 semester units in general education breadth courses. A student may complete 39 units of general education at either college in the Rancho Santiago Community College District prior to transfer. Nine semester units of general education coursework must be completed at the upper division level after transfer.

CERTIFICATION OF GENERAL EDUCATION

1. Santa Ana College is authorized to certify a maximum of 39 general education units.
2. No more than 30 semester units may be certified for areas B through D combined which are described in the next section.
3. Credit/No Credit grades are accepted for certification in all areas, however they are not recommended for transfer credit in basic skill areas. (A. Communication in the English Language and Critical Thinking, A1, A2, and A3; and B. The Physical Universe and Its Life Forms, B4.) In addition, letter grades may be recommended or required for specific courses in a given major. Each CSU campus may also limit the total number of units graded credit.
4. A single course may not meet more than one general education requirement.
5. Requests for certification should be made to the Office of Admissions and Records during the semester prior to the last term of attendance. (Please check deadlines.)
6. Certification of coursework from other colleges will only be granted to students who have completed a minimum of 12 CSU general education units at either college in the Rancho Santiago Community College District or are completing the requirements for a Santa Ana College or Santiago Canyon College degree.
7. Courses taken at other California community colleges will be applied to the subject areas in which they were listed by the institution where the work was completed.
8. Courses taken at other regionally accredited private/out of state institutions (which do not maintain a CSU certification list) will be placed in the subject areas for which Santa Ana College has equivalent courses. Courses completed at foreign institutions are not acceptable for certification.

IMPORTANT NOTE: The list of certifiable courses will be subject to change year by year, but students are assured that courses taken to meet General Education Breadth requirements will be honored if they are approved for the academic year in which they are taken. Courses on this list are approved beginning Fall 2007 and are valid through Summer 2008.

TRANSFER CREDIT

1. Students may transfer up to 70 semester units to the CSU system. Sixty transferable units are needed for junior standing.
 2. All courses used for CSU transfer credit must be numbered 100 or above in the SAC catalog.
- A. Communication in the English Language and Critical Thinking** (minimum 9 units)
The 9 units selected from this area must include at least one course each from A1, A2, and A3. Each course must be completed with a grade of "C" or better. (C minus is not acceptable.)
- A1: Oral Communication**
Speech Communication 101 or 101H, 102, 103 or 103H, 140, 145
- A2: Written Communication**
English 101 or 101H
- A3: Critical Thinking**
Counseling 144
English 103 or 103H
Interdisciplinary Studies 111
Philosophy 110 or 110H, 111, 144
Speech Communication 140

- B. The Physical Universe and Its Life Forms** (minimum 9 units) The 9 units selected from this area must include at least one course each from B1, B2, and B4. The 9 units must also include a corresponding lab component. (Lab classes are in **bold**.) Courses in B4 must be completed with a grade of "C" or better. (C minus is not acceptable.)

B1: Physical Sciences

Astronomy 109, 110 or 110H, 115H, **140**
Chemistry **109, 119, 209, 219 or 219H**
Earth Science 110 or 110H, **115, 150 or 150H**
Environmental Studies **109, 140**
Geography 101, **101L**
Geology 101, **101L, 140, 150 or 150H, 201**
Physical Science **115, 117, 118**
Physics **109, 210, 211, 217, 279**

B2: Life Science

Anthropology 101, **101L**
Biology 109 or 109H, **109L, 139, 149, 159, 177, 211, 212, 214, 229, 239, 259**
Environmental Studies **259**

B3: Laboratory Activity

Anthropology **101L**
Astronomy **140**
Biology **109L, 139, 149, 211, 212, 214, 229, 239, 259**
Chemistry **109, 119, 209, 219 or 219H**
Earth Science **115**
Environmental Studies **109, 259**

Geography 101L

Geology **101L, 201**
Physics **109, 210, 211, 217, 279**
Physical Science **115, 118**

B4: Mathematics/Quantitative Reasoning

Courses must be completed with a grade of "C" or better.
Mathematics 105, 140, 145, 150, 160, 170, 180 or 180H, 219 or 219H
Social Science 219 or 219H

C. Arts, Literature, Philosophy, and Foreign Language

(minimum 9 units) This area must include one course from C1 and one course from C2.

C1: Arts (Art, Dance, Music, Theatre)

Art 100 or 100H, 101, 102, 103, 104, 105, 106
Dance 100 or 100H, 102, 105
English 233A, 233B, 233C, 233D
Interdisciplinary Studies 121
Music 101 or 101H, 102 or 102H, 103, 211
TV/Video Communications 103, 104
Theatre Arts 100, 101, 103, 104, 233A, 233B, 233C, 233D

C2: Humanities

English 102 or 102H, 206, 231, 232, 233A, 233B, 233C, 233D, 241, 242, 243, 245, 246, 270, 271, 272, 278
French 101, 102, 201 or 201H, 202 or 202H
History 101 or 101H, 102 or 102H, 150, 151, 153, 160, 161
Interdisciplinary Studies 200
Japanese 101, 102
Philosophy 106 or 106H, 108, 112, 118
Spanish 101 or 101H, 102 or 102H, 195A, 195B, 201 or 201H, 202 or 202H
Sign Language 110, 112, 116
Theatre Arts 233A, 233B, 233C, 233D
Vietnamese 101, 102

D. Social, Political, and Economic Institutions and Behavior; Historical Background

(minimum 9 units) The 9 units selected from this area must include courses from at least 2 different disciplines.

D1: Anthropology and Archeology

Anthropology 100 or 100H, 103, 104 or 104H, 105, 125
English 104 or 104H
History 105, 125

D2: Economics

Economics 120, 121

Planning to Transfer?

www.assist.org

assist

Your official source for California articulation and student transfer information.

D3: Ethnic Studies

Anthropology 125
Asian American Studies 101
Black Studies 101
Chicano Studies 101
English 245, 278
Ethnic Studies 101 or 101H, 102 or 102H
History 123, 124 or 124H, 125, 146
Psychology 170

D4: Gender Studies

English 245, 278
History 127, 181
Speech Communication 206 or 206H
Women's Studies 101, 102, 201

D5: Geography

Geography 100 or 100H, 102 or 102H,

D6: History

Anthropology 105, 125
History 101 or 101H, 102 or 102H, 105, **118, 120 or 120H, 121 or 121H, 122, 123, 124 or 124H, 125, 127, 133, 146, 150, 151, 153, 160, 161**

D7: Interdisciplinary Social or Behavioral Science

Computer Science 100
Counseling 150
E.S. Professional 150
Human Development 107, 110
Interdisciplinary Studies 117H, 155
Speech Communication 103 or 103H
TV/Video Communications 105 or 105H

D8: Political Science, Government, and Legal Institutions

Political Science 101 or 101H, 200 or 200H, 220,

D9: Psychology

Human Development 107
Psychology 100 or 100H, 140, 157, 170, 200, 219, 230, 240, 250

D10: Sociology and Criminology

Criminal Justice 101
Sociology 100 or 100H, 112, 140 or 140H

NOTE: The CSU Graduation Requirement in **UNITED STATES HISTORY, CONSTITUTION AND AMERICAN IDEALS** may be met by completing Political Science 101 or 101H and one U.S. History course from the following: History 118, 120 or 120H, 121 or 121H, 122, 123, 124 or 124H, 127, 146. These courses (in **bold** above) may also be used to meet 6 of the 9 Area D unit requirements.

E. Lifelong Understanding and Self-Development (minimum 3 units) Three units should be selected from below with no more than one unit from E2.

E1:

Counseling 100, 116, 120, 124, 125, 128
E.S. Health Education 101, 102, 104, 120
E.S. Professional 125
Family & Consumer Studies 120
Human Development 107, 229
Interdisciplinary Studies 155
Nutrition and Food 115 or 115H
Psychology 140, 157, 230
Sociology 112
Speech Communication 104

E2:

E.S. Activities 107, 127, 130, 132, 140, 150, 155, 160, 169, 180, 185, 200, 210, 220, 226, 235, 240, 245, 260, 265, 270, 280, 290, 292
E.S. Adapted Activities 201, 202, 205, 206, 208, 211, 220
E.S. Aerobic Fitness 140, 143, 144, 150, 155, 156, 158, 160
E.S. Aquatics 201, 204, 205, 206, 209
E.S. Fitness 100, 101, 102, 110, 115, 116, 120, 145, 147, 170
E.S. Intercollegiate Athletics 124, 125, 126, 127, 128, 201, 202, 203, 204, 205, 206, 207, 208, 209, 210, 211, 212, 213, 214, 215, 216, 217, 218, 219, 220, 221, 222

INTERSEGMENTAL GENERAL EDUCATION TRANSFER CURRICULUM (IGETC)

Plan C: 2007–2008 Santa Ana College

Completion of all the requirements in the Intersegmental General Education Transfer Curriculum (IGETC) will permit a student to transfer from Santa Ana College to a campus in either the CALIFORNIA STATE UNIVERSITY or the UNIVERSITY OF CALIFORNIA system without the need, after transfer, to take additional lower-division, general education courses to satisfy campus general education requirements.

1. Complete all the listed requirements for IGETC prior to transferring. Partial certification of IGETC is not permitted[†].
2. **Complete all courses used for IGETC certification with a minimum grade of C (C minus is not acceptable).** A “credit” is acceptable providing it is equivalent to a grade of C or higher. The catalog must reflect this policy.
3. Request certification from the last California community college you attend prior to transfer to CSU or UC. Requests should be made to the Office of Admissions and Records during the semester prior to the last term of attendance. (Please check deadlines.)
4. Prior to requesting certification, have all official transcripts on file from every high school and college you have attended.
5. Courses taken at other California community colleges will be applied to the subject areas in which they are listed by the institution where the work was completed.
6. Courses taken at other regionally accredited private/out of state institutions (which do not maintain an IGETC certification list) will be placed in the subject areas for which Santa Ana College has equivalent courses. Equivalency is determined by Santa Ana College faculty teaching the course. Petitions are available from Counseling and must be accompanied by the appropriate documentation.
7. Courses completed at foreign institutions are not acceptable except for certification of competence in a language other than English.

IMPORTANT NOTE: The list of certifiable courses will be subject to change year by year, but students are assured that courses taken to meet IGETC requirements will be honored if they are approved for the academic year in which they are taken. Courses on this list are approved beginning Fall 2007 and are valid through Summer 2008.

AREA 1 - ENGLISH COMMUNICATION

CSU: 3 courses required, one from each group.

UC: 2 courses required, one each from Group A & B.

Group A: English Composition

1 course, minimum 3 units.

English 101** or 101H**.

Group B: Critical Thinking-English Composition

1 course, 3 semester units.

English 103** or 103H** or Philosophy 110 or 110H.

Group C: Oral Communication (CSU ONLY)

1 course, 3 semester units.

Speech Communication 102, 103** or 103H**, 140, 145.

AREA 2 - MATHEMATICAL CONCEPTS & QUANTITATIVE REASONING

1 course, 3 semester units.

Math 105, 140**, 145, 150**, 170**, 180** or 180H**, 185, 219** or 219H**, 270, 280; Social Science 219** or 219H**.

AREA 3 - ARTS & HUMANITIES

3 courses, 9 semester units, with at least one course from Group A and one course from Group B.

Group A: Arts (minimum 3 units)

Art 100** or 100H**, 101, 102, 103, 104, 105, 106; Dance 100** or 100H**, 102, 105; Music 101** or 101H**, 102** or 102H**, 103, 111, 211; Television/Video Communications 103, 104; Theatre Arts 100, 101, 103, 104.

Group B: Humanities (minimum 3 units)

English 102** or 102H**, 206, 231, 232, 233A or 233B or 233C or 233D, 241, 242, 243, 245, 246, 271, 272, 278; French 102, 201** or 201H**, 202** or 202H**, History 101** or 101H**, 102** or 102H**, 150, 151, 153, 160, 161; Interdisciplinary Studies 200; Japanese 102; Philosophy 106** or 106H**, 108, 112, 118; Sign Language 112, 116; Spanish 102** or 102H**, 195A, 195B, 201** or 201H**, 202** or 202H**, Theatre Arts 233A or 233B or 233C or 233D; Vietnamese 102.

AREA 4 - SOCIAL & BEHAVIORAL SCIENCES

3 courses, 9 semester units from at least 2 disciplines or an interdisciplinary sequence.

Anthropology 100** or 100H**, 103, 104** or 104H**, 105, 125; Asian American Studies 101; Black Studies 101; Chicano Studies 101; Criminal Justice 101; Economics 120, 121; English 104** or 104H**, Ethnic Studies 101** or 101H**, 102 or 102H; Geography 100** or 100H**, 102** or 102H**, 138; History 105, 118, 120** or 120H**, 121** or 121H**, 122**, 123, 124** or 124H**, 125, 127, 133, 146, 181; Human Development 107**; Interdisciplinary Studies 117H, 155; Political Science 101** or 101H**, 200** or 200H**, 201, 220; Psychology 100** or 100H**, 140, 157**, 170, 200, 219, 230, 240, 250; Sociology 100** or 100H**, 140** or 140H**, 240; Speech Communication 206** or 206H**, TV/Video Communications 105** or 105H**, Women's Studies 101**, 102, 201**.

AREA 5 - PHYSICAL & BIOLOGICAL SCIENCES

2 courses, 7-9 semester units with one Physical Science course and one Biological Science course; at least one must include a corresponding laboratory (indicated by “L” in parentheses).

Group A: Physical Science (3 units)

Astronomy 109, 110** or 110H**, 115H, 140(L); Chemistry 109(L)**, 119(L)**, 209(L)**, 219(L)** or 219H(L)**, 229(L); Earth Science 110** or 110H**, 115(L)(P), 150** or 150H**, Environmental Studies 109(L)**, 140; Geography 101**, 101(L); Geology 101**, 101(L), 140, 150** or 150H**, 201(L); Physical Science 115(L)(P), 117**, 118(L)**; Physics 109(L)**, 210(L)**, 211(L)**, 217(L)**, 227(L)**, 237(L)**, 279(L)**, 289(L)**.

Group B: Biological Science (3 units)

Anthropology 101, 101(L); Biology 109** or 109H**, 109(L), 177, 211(L), 212(L), 214(L), 229(L), 239(L), 249(L), 259(L); Environmental Studies 259(L).

AREA 6 - LANGUAGE OTHER THAN ENGLISH (U.C. ONLY)

Satisfactory completion of two years of high school coursework in one language other than English with grades of “C” or better***;

OR

completion of one of the following: French 101, Japanese 101, Sign Language 110, Spanish 101 or 101H, or Vietnamese 101;

OR

satisfactory completion, with “C” grades or better, or two years of formal schooling at the sixth grade level or higher in an institution where the language of instruction is not English;

Planning to Transfer?

www.assist.org

Your official source for
California articulation
and student
transfer information.



OR

satisfactory score in examinations of languages other than English: 3 or higher on College Board Advanced Placement Examinations, 5 or higher on International Baccalaureate Higher Level Examinations; SAT II: subject tests (see a counselor for required scores);

OR

satisfactory completion of an achievement test administered by a college in language other than English equivalent to two years of high school language.

AMERICAN INSTITUTIONS REQUIREMENT

(Not part of IGETC. May be completed prior to transfer.)

CSU has an American Institutions graduation requirement that is separate from IGETC. Courses used to meet the CSU requirement cannot be used in Area 3 or 4. To meet the CSU requirement, students should take Political Science 101** or 101H** AND one of the following courses: History 118, 120**, 120H**, 121**, 121H**, 122**, 123, 124**, 124H**, 127, 146.

UC requires the completion of a college course or courses with a grade of “C” or better OR a one-year course in high school in U.S. history or a half-year course in U.S. history and a half-year course in American government with grades of “C” or better (UCLA requires grades of “B”). UCSB requires the completion of a college course. If you are using college coursework to satisfy this requirement, check the appropriate UC catalog to determine which course(s) to take.

[†] For possible exceptions, due to extraordinary circumstances, please see a counselor for guidelines and petition.

* Courses designated with an asterisk may be counted in one area only.

** Indicates that transfer credit may be limited by either UC or CSU or both. Please consult with a counselor for additional information.

*** High School transcript must be on file in the admissions office. Please consult with a counselor for additional information.

(L) Designates courses with a laboratory.

The information above was in effect at press time. Courses with a (P) are pending approval from the UC office of the President and the CSU Chancellor's office. Please consult a counselor before enrolling.

Do you know where your

STUDENT SERVICES FEES

go?

Your fees go to fund these programs and services or to give you discounts:

- Amusement Park Discounts
- ASG Book Loan Program
- Athletic Event Discounts
- Gameroom
- Inter Club Council
- Math Study Center
- Movie Theatre Discounts
- Student Activities Office
- Student Leadership Programs (ASG)
- Transfer Center
- Tutorial Center

Additionally, the Student Services Fee supports academic, cultural, and social programs and activities.

Student Activities for Spring 2008

Sponsored by Associated Student Government (ASG) and Inter-Club Council (ICC) of Santa Ana College

JANUARY

**ASG APPLICATIONS AVAILABLE
BLACK HISTORY MONTH
LUNAR NEW YEAR**

FEBRUARY

**WELCOME BACK EVENTS
CLUB RUSH
NATIONAL CONDOM AWARENESS MONTH**

MARCH

**WOMEN'S HISTORY MONTH
2008-2009 ASG APPLICATIONS AVAILABLE
KINDERCAMINATA**

APRIL

**SPRING RECESS
2008-2009 ASG ELECTIONS
BLOOD DRIVE
INTERNATIONAL STUDENTS SPRING BALL
EARTH WEEK**

MAY

**CINCO DE MAYO
SCHOLARSHIP AWARDS CEREMONY**

JUNE

**FINALS EVENT
COMMENCEMENT**

SANTA ANA COLLEGE FOUNDATION

Established in 1968 and reactivated in 1998, the Santa Ana College Foundation is a non-profit 501(c)3 organization. The Foundation's mission is to maintain, expand and enhance the educational opportunities at Santa Ana College by linking community organizations, businesses, funding sources, alumni and staff, thus preserving our near century of "A History of Success, A Future of Promise."

Here are some ways you can get involved:

- Help strengthen the Foundation and assist with the college's greatest funding priorities with a gift to our unrestricted fund.
- Donate to the General Scholarship Fund or start your own scholarship to help continuing, transferring and incoming students.

- Support the Ed Arnold Golf Classic to assist the Athletic Hall of Fame and student-athletic scholarships.
- Help ignite the mind of a child with a gift to the "Pathways to the Stars" endowment fund that helps to bring over 16,000 youth to our Tessmann Planetarium for educational programs.
- You can "Leave your Legacy" at SAC through a planned gift for the endowment fund or restricted purpose of your choice.

Please visit our web site at <http://www.sac.edu/community/foundation.htm> or call us at (714) 564-6091 to learn more about the Santa Ana College Foundation.

SANTA ANA COLLEGE SCHOOL OF CONTINUING EDUCATION SPRING 2008 CLASS SCHEDULE

FREE CLASSES! CLASSES BEGIN JANUARY 7

For your convenience, we offer classes at over 80 community locations throughout the city of Santa Ana. Please call (714) 241-5700 for more information.

SPRING SEMESTER 2008

Registration Begins	January 2
Instruction Begins	January 7
King's Birthday (holiday).....	January 21
Lincoln's Birthday (holiday).....	February 15
President's Day (holiday)	February 18
Spring Break.....	April 7-11
Memorial Day (holiday).....	May 26
Instruction Ends	May 31
Commencement.....	June 4



CENTENNIAL EDUCATION CENTER
2900 W. Edinger, Santa Ana CA 92704
714-241-5700



MARKETPLACE EDUCATION CENTER
201 E. Fourth St. (Second Floor), Santa Ana CA 92701
714-564-5760

CONTINUING EDUCATION PROGRAMS

Academic, vocational, basic skills and personal enrichment programs are available to adults 18 years or older. Students currently enrolled in high schools, who wish to attend continuing education courses, may be admitted with permission of the high school's principal and local counselors. Students may register for courses throughout the year. Day, evening and Saturday classes are offered at convenient locations throughout Santa Ana.

INSTRUCTIONAL PROGRAMS

ENGLISH AS A SECOND LANGUAGE (ESL)

Provides seven levels of instruction in English language development: listening, speaking, reading and writing for adults. Additional classes include pronunciation, conversation and writing.

ESL/FAMILY LITERACY

Provides English language development with an additional family literacy focus and component of parent and child reading together.

PRONUNCIATION

Develops American English language pronunciation skills.

CONVERSATION

Introduces conversation strategies in listening, English language use, and non-verbal communications. Emphasis on oral skills.

COMMUNITY LEARNING CENTER

Provides adult learners of all English levels the opportunity to improve their English skills, learn about civics, citizenship and computer literacy, through individualized, small group and computer-based instruction.

HIGH SCHOOL SUBJECTS DIPLOMA PROGRAM

Provides all classes necessary to obtain a high school diploma through both traditional and individualized instruction methods.

GED TEST PREPARATION

Prepares adults to pass the GED high school equivalency exam. This course is also offered in Spanish.

SANTA ANA COLLEGE SCHOOL OF CONTINUING EDUCATION

INSTRUCTIONAL PROGRAMS (Continued)

CAHSEE EXIT EXAMS

At some point in 2008, we believe the state will require adult education students to pass an exit exam in order to graduate with a H.S. diploma. Our program also offers instruction to prepare students to take the exam and pass it successfully.

ADULT BASIC EDUCATION (ABE)

Provides adult learners the opportunity to build a strong foundation in reading, writing, language, English usage, communication, technology and math skills as well as job seeking and employment preparation strategies.

CITIZENSHIP

Provides basic knowledge of local, state and federal government in preparation for the United States citizenship examination including language development within the context of history and government.

BUSINESS SKILLS/COMPUTER APPLICATIONS

Provides instruction on current computer applications used in the workplace. Some courses are taught in both English and Spanish.

OFFICE EMPLOYMENT TRAINING PROGRAM

Prepares students for employment, focusing on a combination of general workforce preparation skills and specific office training.

FAMILY CHILD CARE PROVIDERS TRAINING

Provides equal access to healthy, safe and affordable child care for families in low and moderate income neighborhoods in Orange County. Teaches students to establish and maintain a successful home-based child care business. Also, enriches a student's understanding of child development. Classes are offered in English/Vietnamese and Spanish.

COMPUTER BASICS

Teaches functional operations of the hardware and software components of IBM personal computers. Provides advanced training in operating systems and networking fundamentals. Includes instruction and "hands-on" experience in troubleshooting, repairing, maintaining and upgrading computers. Provides instruction in computer hardware and software preparation, review and practice for taking the A+ Certification Test.

OLDER ADULT

Provides a variety of classes specifically for the older adult population in various community locations/ facilities.

PARENT EDUCATION

Provides childbirth preparation and other parent education classes.

SPANISH LITERACY

This program offers Spanish-speaking students the opportunity to improve basic skills in their native language, so they can persist and succeed in ESL and other academic and vocational courses in English.

HIGH SCHOOL DIPLOMA PROGRAMS

GRADUATION REQUIREMENTS:

- Completion of 160 required credits
- Completion of 3 proficiencies: 1. Reading 2. Math 3. Composition
- Verification of First Aid/Health Course
- Completion of one Composition Course
- Must complete at least 15 credits of residency at CEC, MEC, or TSJ

CREDITS FOR HIGH SCHOOL ACCEPTED FROM:

- Previous high school
- Regional occupation programs (up to 20 credits)
- Foreign transcripts
- Approved private schools
- Work experience on the job
- Consumer tasks (independent work given by counselors)
- Armed forces work experience
- College transfer credits

NOTE: GED is not accepted for high school credit.

THE 160 CREDITS REQUIRED FOR GRADUATION

CREDITS NEEDED:

40	English, including composition
20	Math
20	Science
10	Social Studies, World History and Geography
10	U.S. History
10	U.S. Government, Economics
5	Life Skills/Work Experience
10	Fine Arts/Foreign Language
	First Aid/Health Verification
	Proficiencies (3)
35	Electives
160	TOTAL



Concurrently enrolled high school students have the opportunity to earn credits to help them graduate from their local high school.

TO SCHEDULE AN APPOINTMENT WITH A COUNSELOR CALL:

CENTENNIAL EDUCATION CENTER COUNSELING OFFICE:

(714) 241-5720 or 241-5721

Counseling Department Hours:

Monday – Thursday 8:00 a.m.–9:00 p.m.
 Friday 8:00 a.m.–12:00 p.m.
 Saturday 8:30 a.m.–2:30 p.m.

MARKETPLACE EDUCATION CENTER COUNSELING OFFICE: (714) 564-5790

Counseling Department Hours:

Monday & Tuesday 8:30 a.m.–2:30 p.m.
 & 5:00 p.m.–9:00 p.m.
 Wednesday & Thursday 9:00 a.m.–1:00 p.m.
 & 5:00 p.m.–9:00 p.m.
 Friday 8:00 a.m.–12:00 p.m.
 Saturday 8:00 a.m.–12:00 p.m.

TALLER SAN JOSE (714) 543-5105

Counseling Department Hours:

Saturday 8:00 a.m.–11:00 a.m.

SANTA ANA COLLEGE SCHOOL OF CONTINUING EDUCATION

REGISTRATION INFORMATION

CENTENNIAL EDUCATION CENTER

2900 W. Edinger, Santa Ana CA 92704
714-241-5700

REGISTRATION HOURS:

Time: 8:00 a.m. – 9:00 p.m. Monday – Thursday
8:00 a.m. – 12:00 p.m. Friday
8:30 a.m. – 12:30 p.m. Saturday
Spring registration begins January 2

MARKETPLACE EDUCATION CENTER

201 E. Fourth St. (Second Floor)
714-564-5760

REGISTRATION HOURS:

Time: 8:00 a.m. – 9:00 p.m. Monday – Thursday
8:00 a.m. – 12:00 p.m. Friday
8:00 a.m. – 3:00 p.m. Saturday
Spring registration begins January 2

STUDENT SERVICES & PROGRAMS

COUNSELING DEPARTMENT

Assists students in meeting their educational and career life goals through orientation, academic advisement, assessment, career planning, testing, workshops and individual and group counseling.

STUDENT OUTREACH AND CAREER CENTER

Career information, exploration, research materials and computer software to conduct skills, abilities and interest inventories for college and vocational searches. Assist with resumes and college applications. Provide outreach services to the community and assists with student recruitment.

CHILD DEVELOPMENT PROGRAMS

Provides early childhood education while parents are pursuing their education.

DISABLED STUDENT PROGRAMS AND SERVICES

Assist students who have average or above average potential for learning and who exhibit difficulties in at least one academic area. Students who qualify may enroll in the Learning Skills Program and receive various services.

TUTORING PROGRAM

Tutoring is available during the day and evening hours, covering most subjects including English, conversational practice, basic computers, math, literacy, ABE and High School Subjects.

STUDENT DEVELOPMENT

Provides students with opportunities to participate in leadership training classes, student association, clubs, student conferences, celebrations, and other activities.

CalWORKs

Provides counseling and assistance to all CalWORKs eligible students.

SATURDAY CLASSES AVAILABLE!

We offer classes that meet only on Saturdays for students who can't attend during the week. Saturday classes are offered only at CEC, MEC, and Lincoln Elementary School.

CLASS SCHEDULE SUBJECT TO CHANGE

The Rancho Santiago Community College District has made every reasonable effort to determine that everything stated in this class schedule is accurate. Courses and programs offered, together with other matters contained herein, are subject to change without notice by the administration of the Rancho Santiago Community College District for reasons related to student enrollment, level of financial support, or for any other reason, at the discretion of the District. Individuals should call (714) 241-5700 to verify class times and dates.

CONTINUING EDUCATION SITES

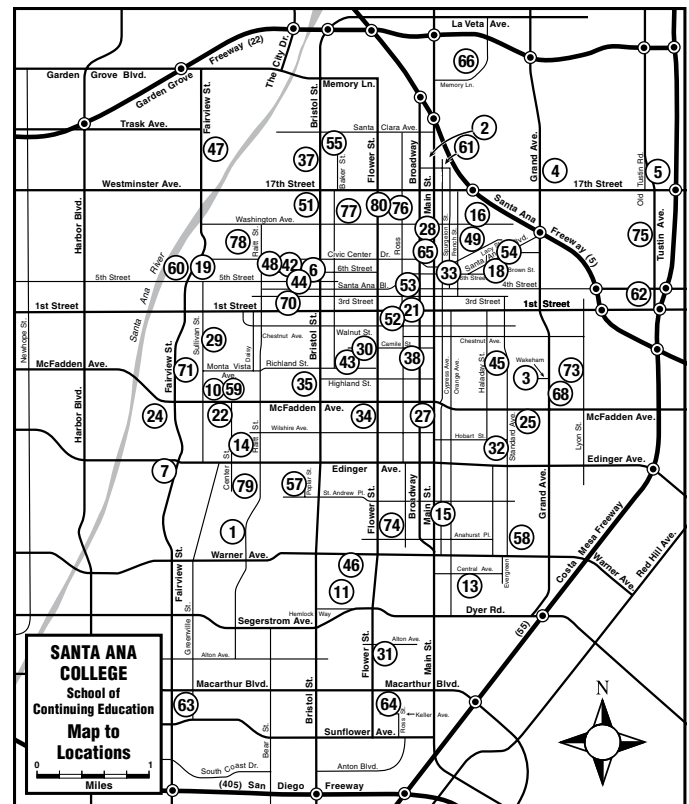

SANTA ANA COLLEGE SCHOOL OF CONTINUING EDUCATION

REGISTRATION AT OUR COMMUNITY SITES:

Register directly in class with the instructor. For class information and times, please call Centennial Education Center at (714) 241-5700.

COMMUNITY LOCATIONS

Centennial Education Center: (7)

Centennial Education Center is the main administrative site for all Santa Ana Continuing Education Classes.

Register in the main office:

2900 West Edinger Avenue, Santa Ana

714-241-5700

Office Hours:

Monday – Thursday: 8:00 a.m. - 9:00 p.m.

Friday: 8:00 a.m. – 1:00 p.m.

Saturday: 8:30 a.m. – 12:30 p.m.

Morning, Afternoon, and Evening Classes

Monday – Thursday, Friday and Saturday

Adult Basic Skills Review

Beginning ESL 1, 2, 3

Intermediate ESL 1, 2, 3

American English Pronunciation

Community Learning Center

Conversation 1, 2

ESL/Family Literacy

Adult Basic Education (ABE)

Citizenship

Business Skills

Office Employment Training

High School Subjects Diploma Program

GED Test Preparation

Learning Skills and Strategies

On-Site Registration Is Available At The Following Locations:

Adams Elementary (1)

2130 S. Raitt St.

Morning and evening classes

ESL/Family Literacy,

Beginning 1 and 2

Bowers Kidseum (2)

1802 N. Main St.

Seminar for Older Adults

Effective Parenting

Cambodian Family (3) – register in class

1111 East Wakeham Avenue, Suite E

Morning classes

VESL: English for Work 1 and 2

CANO Head Start (4)

1745 North Grand Avenue

Morning classes

Beginning ESL 1

Carver Elementary School (6)

1401 West Santa Ana Boulevard

Evening classes

ESL/Family Literacy Beginning 1 and 2

Corbin Center (10)

2215 West McFadden

Morning and evening classes

Monday - Thursday

ESL/Family Literacy Beginning 1, 2 and 3

Beginning ESL 1

Orientation to Computers

Delhi Recreation Center (13)

505 East Central Avenue

Morning, afternoon, and evening classes

Orientation to Computers

Beginning ESL 1 and

ESL/Family Literacy Beginning 1 and 2

Physical Fitness for Older Adults

Effective Parenting (in Spanish)

Increasing Parent Awareness of US Schools

Diamond Elementary School (14)

1450 South Center

Evening classes

ESL/Family Literacy, Beginning 1, 2, and 3

Edison Elementary School (15)

2063 Orange Street

Evening classes

ESL/Family Literacy, Beginning 1

Fremont Elementary (78)

1930 W. Tenth St.

ESL/Family Literacy

Classes to be announced

Garfield Elementary School (18)

850 Brown

Evening classes

ESL/Family Literacy, Beginning 1

Goodwill Industries (19)

5th and Fairview

Morning and Afternoon classes

Independent Living Skills for Developmentally

Disabled

Personal Grooming for the Developmentally

Disabled

Beginning ESL 1

Harvey Elementary (79)

1635 S. Center St.

Evening classes

ESL/Family Literacy, Beginning 1

Heninger Elementary School (21)

417 West Walnut

Morning classes

ESL/Family Literacy, Beginning 1, 2, and 3

Immaculate Heart of Mary Church (22)

1100 S. Center St.

Beginning ESL 1 and 2

Jackson Elementary School (24)

1143 Nakoma Drive

Evening classes

ESL/Family Literacy, Beginning 1

Kennedy Elementary School (25)

1300 East MacFadden

Evening classes

ESL/Family Literacy, Beginning 1, 2, and 3

Citizenship (in Spanish)

KidWorks (26)

1902 W. Chestnut

Morning and evening classes

ESL/Family Literacy, Beginning 1 and 2

Libreria Martinez (28)*

1110 N. Main St.

Classes to be announced

Lathrop Intermediate School (27)

1111 South Broadway

Evening classes

ESL/Family Literacy, Beginning 1 and 2

Lincoln Elementary School (29)

425 South Sullivan

Morning and Evening classes

ESL/Family Literacy, Beginning 1, 2, and 3

GED Test Preparation

Spanish Literacy

Lowell Elementary School (30)

700 South Flower

Evening classes

ESL/Family Literacy, Beginning 1 and 2

MacArthur Fundamental

Intermediate School (31)

600 West Alton

Evening classes

Monday and Wednesday

ESL/Family Literacy, Beginning 3 and Intermediate 1

Madison Elementary School (32)

1124 East Hobart

Morning classes

ESL/Family Literacy, Beginning 1, 2, and 3

Marketplace Education Center (33)

201 East Fourth Street,

Santa Ana (corner of Fourth & Bush)

Morning, Afternoon, and Evening classes

Monday through Saturday

Adult Basic Education (ABE)

Citizenship

Beginning ESL 1, 2, and 3

Intermediate ESL 1, 2, and 3

American English Pronunciation

Conversation 1

Community Learning Center

High School Subjects Diploma Program

GED Test Preparation

Computer Applications Lab

Computer Basic Operations

Office Employment Training

Microcomputer Computer Repair

Spanish Literacy

Vocational Academic Skills

CITIZENSHIP

Continuing Education offers citizenship preparation classes. For more information contact the Student Outreach and Career Center at (714) 241-5730.

continued on next page...

SANTA ANA COLLEGE SCHOOL OF CONTINUING EDUCATION

COMMUNITY LOCATIONS (Continued)

Martin Elementary School (34)

939 West Wilshire
Evening classes
ESL/Family Literacy, Beginning 1 and 2

Martin Luther King Elementary School (35)

1001 South Graham Lane
Evening classes
Monday - Thursday
ESL/Family Literacy, Beginning 1, 2, and 3

Mendez Fundamental

Intermediate School (37)

2000 North Bristol
Evening classes
Microcomputer Repair

Mexican American Opportunity Foundation (38)

520 South Ross
Morning and Evening Classes
*Basic Computer Operations
Beginning Word Processing*

Our Lady of Pilar Church (42)

1622 West 6th Street
Evening classes
*Beginning ESL 1
Orientation to Computers*

Pio Pico Elementary School (43)

931 West Highland
Morning classes
ESL/Family Literacy, Beginning 2 and 3

Romero Cruz Elementary School (44)

1512 West Santa Ana Blvd.
Evening classes
*ESL Family Literacy, Beginning 3
ESL Family Literacy Intermediate 1
Computer Applications
GED Test Preparation*

Roosevelt Elementary School (45)

501 South Halladay
Evening classes
ESL/Family Literacy, Beginning 1 and 2

Saint Joseph's School (49)

608 Civic Center Drive
Morning classes
Beginning ESL 1

Santa Ana College (51)

1530 West 17th Street
Morning, Afternoon, Evening classes
*Adult Basic Education (ABE)
Computer Applications
High School Subjects Diploma Program
Increasing Parent Awareness of US Schools
Micro enterprise Childcare Providers Program
Personal Grooming for Dev. Disabled Adults
Student Leadership*

Santa Ana High School (52)

520 West Walnut
Evening classes
*ABE
Beginning ESL 1, 2, and 3
ESL Literacy
Intermediate ESL 1, 2, and 3*

Santa Ana Work Center (54)

1000 East Santa Ana Boulevard
Afternoon classes
Workforce Preparation

Santiago Elementary School (55)

1243 N. Baker St.
Morning classes
ESL/Family Literacy, Beginning 1

Sepulveda Elementary School (57)

1801 South Poplar
Evening classes
ESL/Family Literacy, Beginning 1 and 2

SER (Service Employment Redevelopment) (58)

1243 East Warner, Santa Ana
Morning classes, 8:00 a.m. – Noon
Monday - Friday
*Adult Basic Education (ABE)
Beginning ESL 1 and 2
Intermediate ESL 2
Business Skills
GED Test Preparation*

Spurgeon Intermediate School (60)

2701 West Fifth Street
Evening classes
*Beginning ESL 1, 2, and 3
Intermediate ESL 1, 2, and 3*

Taft Elementary School (64)

500 West Keller
Evening classes
ESL/Family Literacy, Beginning 1 and 2

Taller San Jose (65)

801 North Broadway
Morning and Afternoon classes
*ABE Skills
High School Subjects
Computer Applications
Microcomputer Repair*

Vietnamese Community Center (70)

1618 West First Street
Morning and Afternoon classes
*Citizenship
Beginning ESL 1 and 2
Computer Applications*

Villa del Sol (71)

811 S. Fairview

Warwick Square Apartments (74)

780 S. Lyon St.
Morning classes
ESL/Family Literacy, Beginning 1

Washington Elementary School (75)

910 Anahurst Place
Morning and Evening classes
*ESL/Family Literacy, Beginning 1, 2, and 3
ESL/Family Literacy, Intermediate 1*

Western Medical Center (75)

1001 North Tustin Avenue, Santa Ana
(Call 241-5700 for information about registration)
Evening classes
*Effective Parenting
Preparation for Childbirth*

Willard Intermediate School (76)

1342 North Ross
Evening classes
ESL/Family Literacy, Beginning 1 and 2

Wilson Elementary School (77)

1317 North Baker Street
Afternoon and evening classes
ESL/Family Literacy, Beginning 1 and 2

THE FOLLOWING OLDER ADULT PROGRAMS ARE OFFERED AT THESE SITES:

*Choral Dynamics for Older Adults
Creative Cooking for Older Adults
Manipulative Skills for Older Adults
Music Arts for Older Adults
Physical Fitness for Older Adults
Seminar for Older Adults*

Carehouse Windsor Hall (5)

1800 Old Tustin Road, Santa Ana

Country Villa Plaza (11)

1209 Hemlock Way, Santa Ana

Delhi Community and Recreation Center (13)

505 East Central Avenue, Santa Ana

French Park (16)

601 E. Washington, Santa Ana

Royale Convalescent Center (46)

1929 West Warner Avenue, Santa Ana

Santa Ana Senior Center (53)

424 West Third Street, Santa Ana

Southwest Senior Center (59)

2201 West McFadden Avenue, Santa Ana

St. Edna's Convalescent Center (47)

1929 North Fairview, Santa Ana

St. Frances Home (48)

1718 West 6th Street, Santa Ana

Summerville at Main Place (61)

2025 North Bush Street, Santa Ana

SunBridge Care and Rehab (62)

2201 East 1st Street, Santa Ana

Sunflower Gardens (63)

3720 South Greenville, Santa Ana

Town and Country Manor (66)

555 East Memory Lane, Santa Ana

Very Independent Persons Center (68)

1101 South Grand, Suite L & M, Santa Ana

Wycliffe Plaza (80)

1401 N Flower St.

INFORMATION ABOUT REGISTRATION FOR CLASSES AT OTHER SANTA ANA AREA SITES NOT LISTED ABOVE IS AVAILABLE AT CENTENNIAL EDUCATION CENTER, 241-5700

RANCHO SANTIAGO COMMUNITY COLLEGE DISTRICT

SANTA ANA COLLEGE • SANTIAGO CANYON COLLEGE

MAJOR SITES

- 1 RSCCD Operations Center2323 N. Broadway.....Santa Ana
- 2 Santa Ana College (SAC)1530 W. 17th Street.....Santa Ana
- 3 Santiago Canyon College (SCC).....8045 E. Chapman Avenue.....Orange
- 4 SCC Orange Education Center (OEC)1465 N. Batavia StreetOrange
- 5 Centennial Education Center (CEC).....2900 W. Edinger AvenueSanta Ana
- 6 Orange County Sheriff's Department Training Center (OCST).....1900 W. Katella Avenue.....Orange
- 7 Orange County Sheriff's Regional Training Academy (CJTC).....15991 Armstrong Ave.....Tustin
- 8 Marketplace Education Center (MEC)201 E. Fourth StreetSanta Ana
- 9 Anaheim Hills Center (AHC).....101 S. ChaparralAnaheim Hills
- 10 Digital Media Center (DMC)1300 S. Bristol StreetSanta Ana
- 11 Joint Powers Training Center (JPTC CN).....18301 GothardHuntington Beach
- 12 Orange County Probation Department.....1001 S. Grand AvenueSanta Ana

MAPS - MAJOR SITES

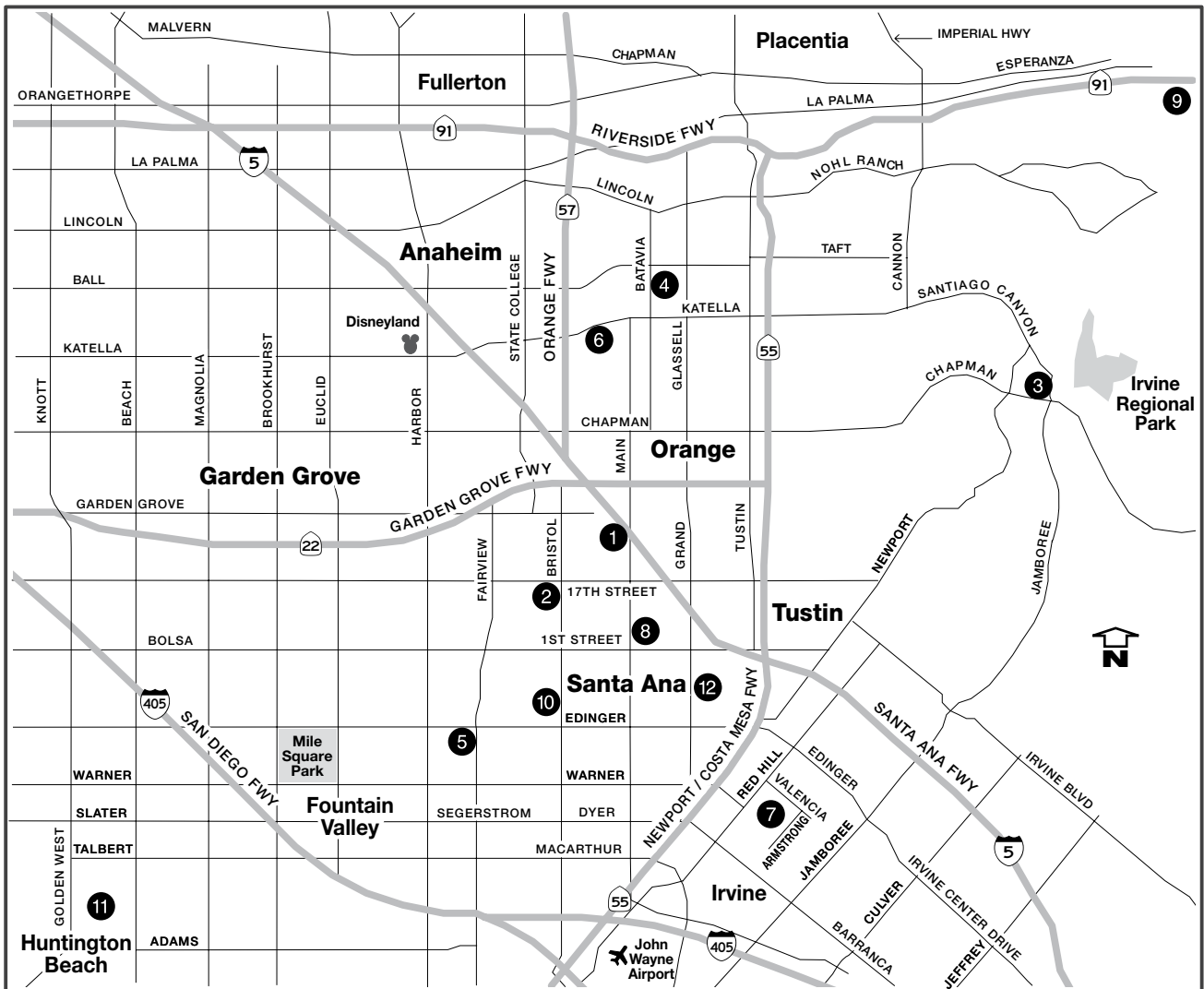

SANTA ANA COLLEGE

1530 W. 17th Street
 Santa Ana, CA 92706
 (714) 564-6000

SAC FACILITIES AND LOCATIONS

- A Cesar Chavez Building / Business / Computer
- B International Students Program / Services / Middle College High School
- C Fine Arts / Art Gallery
- CDC Child Development Center
- D Dunlap Hall / Amphitheatre (west of building)
- E Exercise Science
- F Locker Rooms
- G Cook Gym
- H Hammond Hall
- J Auto Shop
- K Welding / Auto Diesel / Maintenance / Warehouse
- L Nealley Library and ALC
- M Museum / Planetarium
- N Music Building
- P Phillips Hall Theatre
- R Russell Hall
- S Administration Building / Admissions / Counseling
- T Technical Arts
- U Johnson Center / Student Business Office / Bookstore / Cafeteria
- W Physical Education
- X Security / Safety
- Z Maintenance

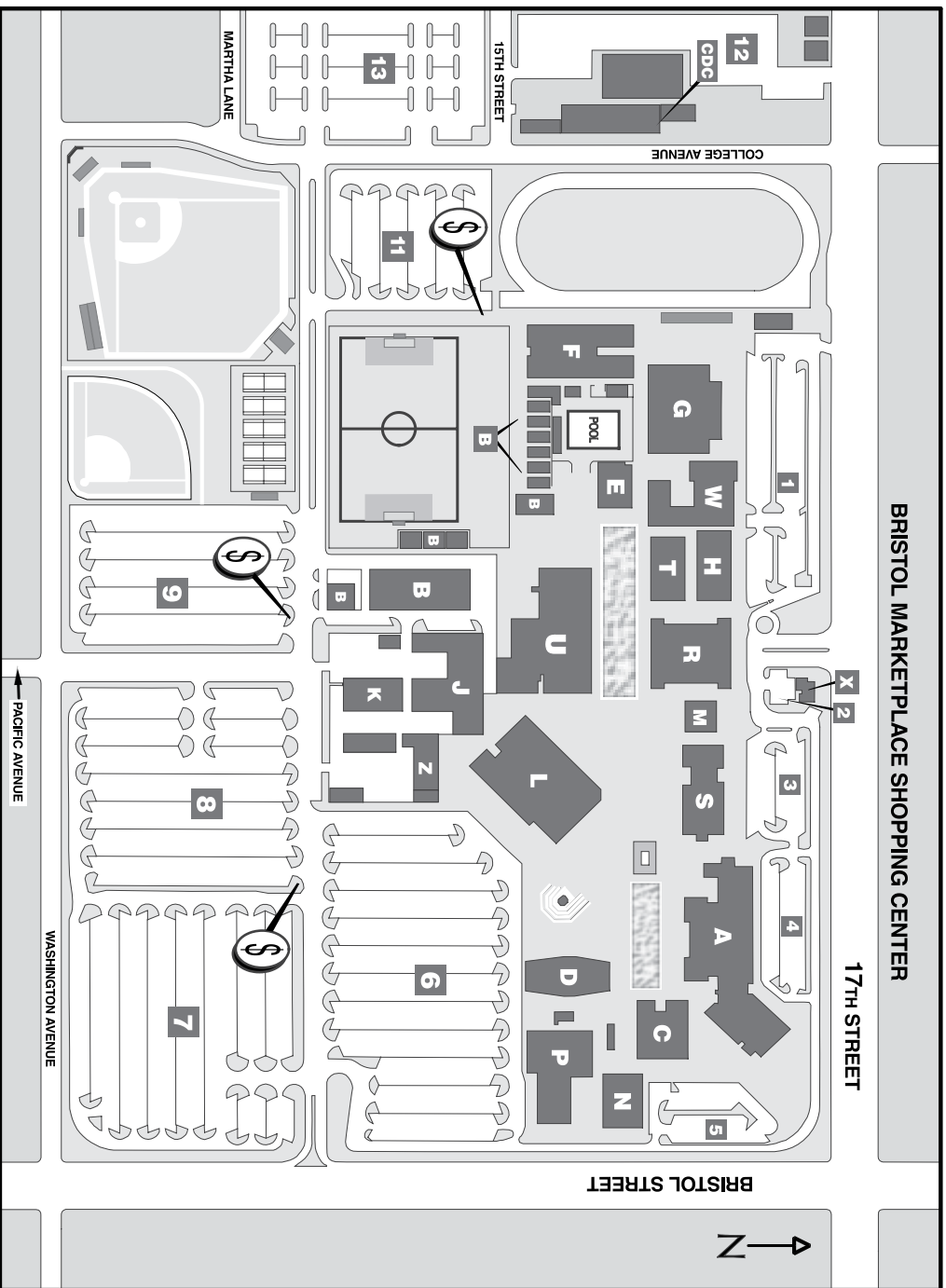

SAC Parking

- 1 Staff Parking
- 2 Visitor Parking
- 3 Staff Parking
- 4 Student Parking (except as posted)
- 5 Student Parking (except as posted)
- 6-13 Permit Dispenser (\$1.00 for 8 hours)

\$

Designated Smoking Areas at SAC (Smoking permitted in these places and parking lots only.)

SUPWMA SAC – PAW